



**BMBD030
BMBD036
Semi Automatic Bun Divider
Operations Manual**



Questions? Contact Us:

Toll Free: 1-800-565-2253

Email: Info@BakeMax.com

www.BakeMax.com

Warranty Registration

www.BakeMax.com/Warranty-Registration



WARNING: PLEASE READ AND FOLLOW THE INSTRUCTIONS BELOW BEFORE OPERATING PRODUCT

- When using the machine, please confirm that you have read all the instructions within this manual.
- Beware of any child/children or any other persons who are near the machine before operating.
- Do not put hand near moving parts.
- Remove all obstacles, which may interfere with machine functions.
- Keep work area clean and clear of clutter.
- Do not sit or stand on machine
- Do not wear loose cloth or jewellery when operating machine as it may get caught in moving parts and cause injury
- When the machine is abnormal or broken, you should stop using and check it or have it checked by a professional.
- Disconnect from power source before performing maintenance on the machine.
- When machine is not in use, please clean and store properly.
- Do not place any electrical parts or plug/cord in water.
- The cord should be away from the heat.
- Don't hang out the cord on the desk or cabinet.
- Machine may have sharp or pointed edges, use caution when cleaning.
- This machine should only be operated by personnel who can read, understand and respect warnings and instructions regarding this machine and the manual.
- Keep this manual in a safe place for further and regular reference and ordering parts.
- Please write model serial and date of purchase of your machine in the space provided in case you will need to order parts in the future.
- Always work by security code of your country, state, province, city or committee of your work place.

BMBD036 SEMI-AUTOMATIC DOUGH DIVIDER/ROUNDER OPERATION MANUAL

CONTENTS

1. PREFACE. -----	P2.
2. THE MACHINE INTRODUCTION. -----	P2.
3. THE MACHINE SPECIFICATION. -----	P2.
4. THE NAMES OF THE PARTS IN THIS MACHINE.—	P3.
5. METHOD OF TRANSPORTATION. -----	P4.
6. METHOD OF INSTALLATION & CAUTIONS. -----	P4.
7. OPERATION INSTRUCTION & NOTICE. -----	P6.
8. CLEANING & MAINTENANCE. -----	P7.
9. ASSEMBLY DRAWING & PARTS LIST. -----	P8.
10. ELECTRIC CONTROL DIAGRAM & PARTS LIST.—	P12.

1. PREFACE

OUR SEMI-AUTOMATIC DOUGH DIVIDER / ROUNDER ARE THE BEST HELPER IN YOUR BAKERY. IT CAN BE YOUR BEST WORKING PARTNER IF YOU REFER TO THIS INSTRUCTION MANUAL FOR USAGE AND MAINTENANCE.

2. MACHINE INTRODUCTION

OUR SEMI-AUTOMATIC DOUGH DIVIDER/ROUNDER HAS THE FUNCTION TO EVENLY DIVIDE THE DOUGH PIECE INTO SMALL PIECES THEN ROUNDER THEM ROUNDLY. THERE ARE TWO MODELS BMBD030 IS FOR DIVIDING EACH INTO 30 PIECES WHILE BMBD036 IS FOR DIVIDING EACH INTO 36 PIECES.

3. MACHINE SPECIFICATION

MODEL		BMBD030	BMBD036
DOUGH WEIGHT RANGE	GM	30-100	30-100
NUMBER OF PIECES		30	36
POWER	KW	0.75	0.75
NET WEIGHT	KG	360	360
CARTON DIM	CM	84 x 93 x 160	84 x 93 x 160

Dimensions (cm)

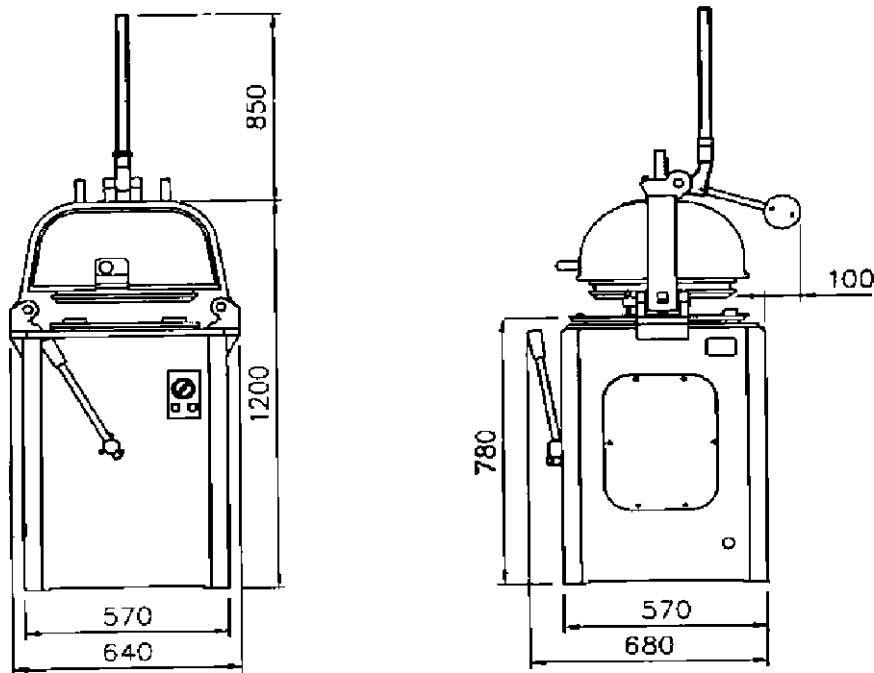

4. THE NAMES OF THE PARTS IN THIS MACHINE

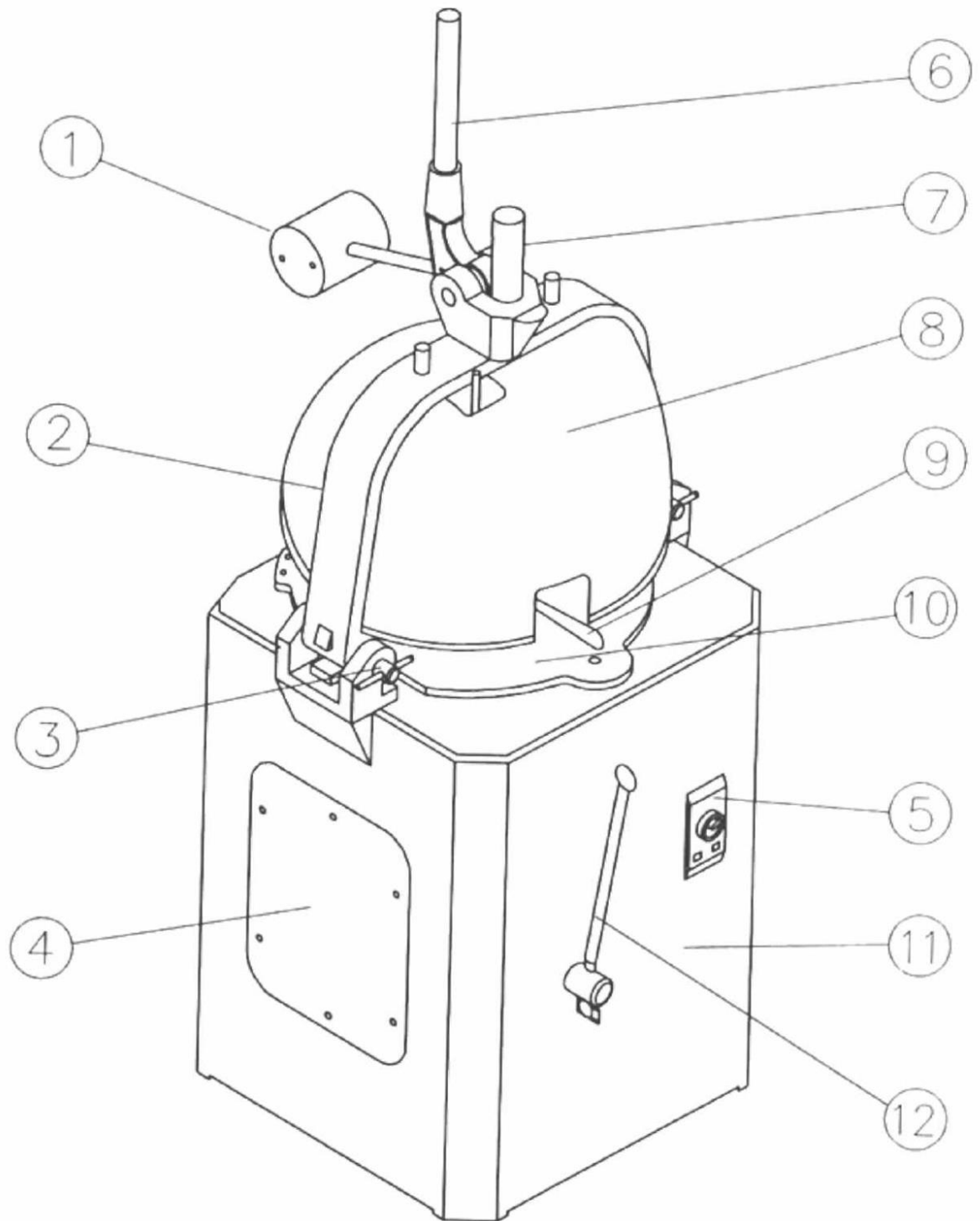

NO.	DESIGNATION	NO.	DESIGNATION
1	BALANCE	7	SHAFT
2	YOKE	8	FRONT HOOD
3	CLAMPING LEVER	9	CUTTING HANDLE
4	COVER	10	MOULDING PLATE
5	POWER SWITCH	11	HOUSING
6	PRESSING LEVER	12	MOULDING LEVER

5. METHOD OF TRANSPORTATION

- A) USING 1 TON FORKLIFT TO MOVE THE EQUIPMENT TO ADEQUATE POSITION FOR UNPACKING.
- B) TO REMOVE THE WOODEN CASE AND LEAVE THE SKID, THEN USING THE CROSS SCREW DRIVER AND WRENCH TO REMOVER THE SIDE COVER AND 4 PIECES OF BUTTOM FIXING M10.
- C) TO LIFT UP THE NYLON BELT BY FORKLIFT, OFF THE SKID AND FIX THE EQUIPMENT ONTO THE INSTALLATION PLACE.

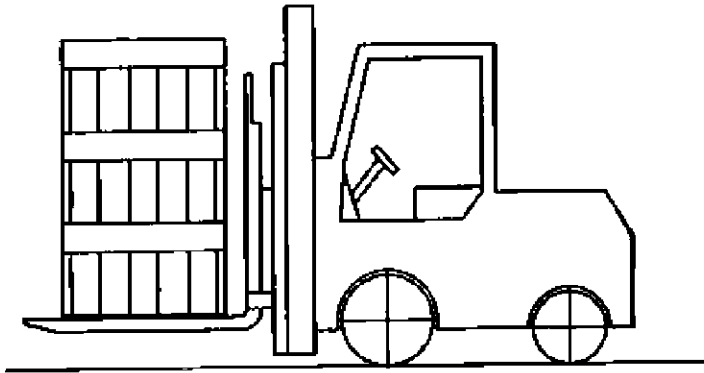

fig(1)

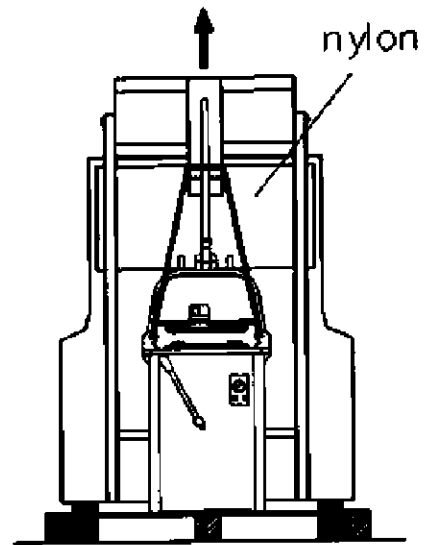

fig(2)

6. METHOD OF INSTALLATION & CAUTIONS

METHOD OF INSTALLATION

- A) THE EQUIPMENT MUST BE INSTALLED ONTO A PLAIN FLOOR.
- B) THERE MUST BE SUFFICIENT SPACE AS SHOWN ON THE SKETCH FOR OPERATION AND CLEANING
- C) TO REMOVE THE COVER NO.4 AND HAVE THOSE 4 ANTI-VIBRATION PADS FIXED AT FOUR CORNERS OF THE EQUIPMENT. IT IS REQUESTED TO ENSURE THE PADS HAVE BEEN STEADILY FIXED AND MAKE EACH ONE HOLE IN DIAMETER OF 1/2" AT EACH CORNER.
- D) TO TIGHTLY SCREW IN 4*3/8" SCREWS AND RE-INSTALL THEM BACK TO THE SIDE COVER.
- E) TO ASK ELECTRIC ENGINEER TO ENERGIZE AND ENSURE THE POWER MEETS WHAT STATED ON THE NAMEPLATE.

- F)** TO MAKE TEST RUN ON THE MOULDING LEVEL NO. 12. THE DIRECTION OF MOULDING NO.10 SHOULD BE COUNTER-CLOCKWISE AS THE ARROW'S DIRECTION.
- G)** TO HOLD THE PRESSING LEVER NO.6 BY HAND AND INSERT IN THE PART OF TOOTH SEGMENT NO. 1-28 ALONG THE ARROW'S DIRECTION THEN TO TIGHTLY SCREW.

CAUTIONS

- A)** IT IS ESSENTIAL TO ASK PROFESSIONAL ENGINEER TO MAKE INSTALLATION AND TEST-RUN.
- B)** THE EQUIPMENT HAS ALREADY BEEN FILLED WITH ADEQUATE OIL UPON TEST-RUN, IF THERE IS ANY LEAKAGE DURING TRANSPORTATION, PLEASE CHECK THE OIL CONTENT OF SLIDE BEARING NO.1-60 AGAIN WITH PROCEDURES AS: TAKE OFF THE CLAMPING LEVER NO.3, PULL UP THE TOP OF MACHINE, USE TWO HANDS TO PICK UP THE MOULDING PLATE NO.10, THE OIL CONTENT SHOULD BE 5mm HIGHER THAN BOTH CONVEX SIDES FOR NORMAL OPERATION.
- C)** IT WILL BE VERY HELPFUL TO ENLARGE THE OPERATION AND IT'S LIFE IF YOU SELECT A SMOOTH PLAIN POSITION FOR FIXING THE MACHINE.

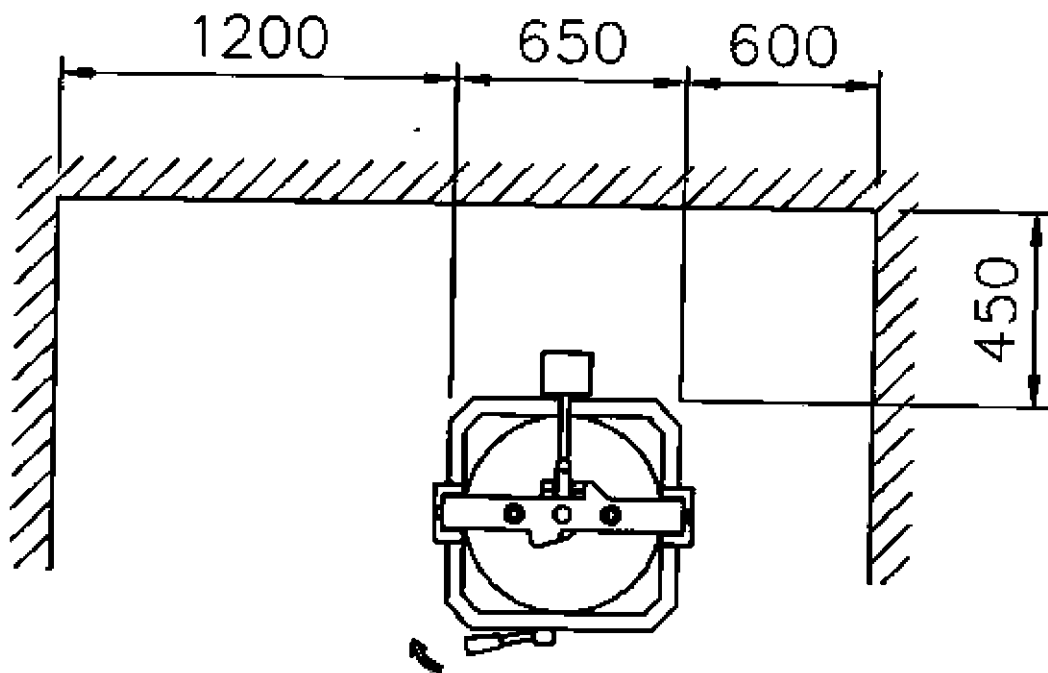

7. OPERATION INSTRUCTION

PRE-CLEANING:

- A) CLEAN THE RUST PREVENTIVE OIL ON THE KNIFE NO.1-06, MOULDING PLATE NO.10, AND THE CHECK RING.
- B) BEFORE FORMAL PRODUCTION, PLEASE USE ABOUT 2KG DOUGH TO REPEATEDLY OPERATE THE MACHINE TO ENSURE IT CAN BE WELL CLEAN AND BETTER OPERATION AFTERWARDS.

OPERATION:

- A) TURN ON THE POWER SWITCH NO.5 TO THE RIGHT FOR STARTING IT.
- B) TRY TO PRESS THE MOULDING LEVER NO.12, THE MOULDING PLATE NO.10 SHOULD GO COUNTER-CLOCKWISE DIRECTION.
- C) PREPARE THE DOUGH AND PLASTIC PLATE NO.1-36 TO PRACTICE THE PROCEDURES FOR A COUPLE TIMES TO ENSURE YOU CAN BE FAMILIAR WITH THE PROCEDURES. TO COMPLETELY STIR A BIG PIECE OF DOUGH WHICH ENOUGH TO BE DIVIDED INTO 30 OR 36 PIECES AND SMOOTHLY PUT IT ON THE PLASTIC PLATE NO.1-36, AFTER HAS TO REST A SHORT TIME. WHEN THE PLASTIC PLATE NO.1-36 IS PUT ONTO THE MOULDING PLATE NO.10 OF MACHINE. IT MUST BE FIXED STEADILY WITHOUT MOVING.
- D) TO ADJUST THE HEIGHT OF MOULDING SPACE TO BE REFERED THE WEIGHT OF DOUGH AND THE INDICATION ON THE SCALE. SUCH AS THE CARVE OF 60 REFERS TO 60 GRAMS PER PIECE OF DOUGH. IT IS REQUIRED TO SECURELY FIXED THE SLEEVE NUT NO.1-70 AGAIN TO PREVENT FROM LOSSING. AS IT WILL DAMAGE THE SURFACE OF DOUGH AND MAKE IT PLAIN IF THE CARVE IS TOO SMALL AND IT WILL NOT BE AS ROUND AS YOU EXPECT IF THE CARVE IS TOO BIG.
- E) TO PULL DOWN THE PRESSING LEVER NO.6 TO HAVE THE DOUGH PRESSED TIGHTLY AND USING LEFT HAND TO PUSH THE CUTTING HANDLE AND PRESS THE PRESSING LEVER NO.6 TO DIVIDE THE DOUGH.
- F) DEPRESS FULLY THE MOULDING LEVER NO.12 SLOWLY. HAVE ROUNDING MOULDING PLATE NO.10 FOR 3-5 SECONDS AND SHIFT IT BACK GRADUALLY.
- G) LIFT THE PRESSING LEVER NO.6 TO STOP POSITION AND REMOVE THE PLASTIC PLATE NO.1-36 WITH ROUNDED PIECES FROM THE MACHINE.

CAUTION

- A) KEEP PEOPLE OFF THE MACHINE UPON OPERATION AND THE OPERATOR ALSO SHOULD KEEP HIMSELF (OR HERSELF) OFF THE MACHINE.**
- B) WHEN USING IT FOR DIVIDING AND ROUNDING, THE TOTAL WEIGHT SHOULD BE LESS THAN 3KG OR 3.6KG.**
- C) IT WILL DAMAGE THE CUTTING EQUIPMENT IF ANY METAL AND HARD MATERIALS**
- D) MIXING INTO THE DOUGH.**

8. CLEANING AND MAINTENANCE

THE PARTS SHOULD BE CLEANING DAILY AFTER OPERATION

- A) TURN OFF THE POWER SWITCH NO.5 AND PULL UP THE TOP OF MACHINE, WEIGHT DOWN THE PRESSING LEVER NO.6 AND PUSH THE CUTTING HANDLE NO.33, EMERGEING CUTTING KNIFE TO BRUSH AND CLEAN THE KNIFENO.1-06, KNIFEHEAD, DOUGH CHECK RING, MOULDING PLATE NO.10.**
- B) IT'S VERY IMPORTANT TO KEEP THE OPPOSITE SIDE OF THE MOULDING PLATE NO.10 AND THE PLASTIC PLATE NO.1-36 CLEANING.**
- C) AFTER BRUSHING, PLEASE DRY UP THE PLASTIC PLATE NO.1-36 BY NATURE, BUT CAN'T BE ROASTED, FREEZED OR PLACED IT AT RANDOM, IT WILL BE DETERIORATED.**

MAINTENANCE

- A) IF THE ROUNDER WORKS SLOWER, IT MEANS THE BELT IS LOOSE AFTER USING FOR A COUPLE YEARS. PLEASE ADJUST IT BY TIGHTEN THE SCREWS.**
- B) USING LUBRICANT OIL SUCH AS A360B LUBRICANT OR PHILIP PF FOOD OIL FOR MAINTENANCE. IT IS DEFINITELY PROHIBITTED TO US GENERAL OIL OR FOOD OIL TO DO MAINTENANCE.**
- C) PLEASE CHECK THE SUFFICIENCY OF THE OIL CONTENT OF SLIDE BEARING NO.1-60 EVERY 3 MONTHS. WHEN RE-FILLING OVER 5mm. PLEASE ADD MEDIUM CIRCULATION R68 OIL AS THE SAME TIME.**

9. ASSEMBLY DRAWING & PARTS LIST

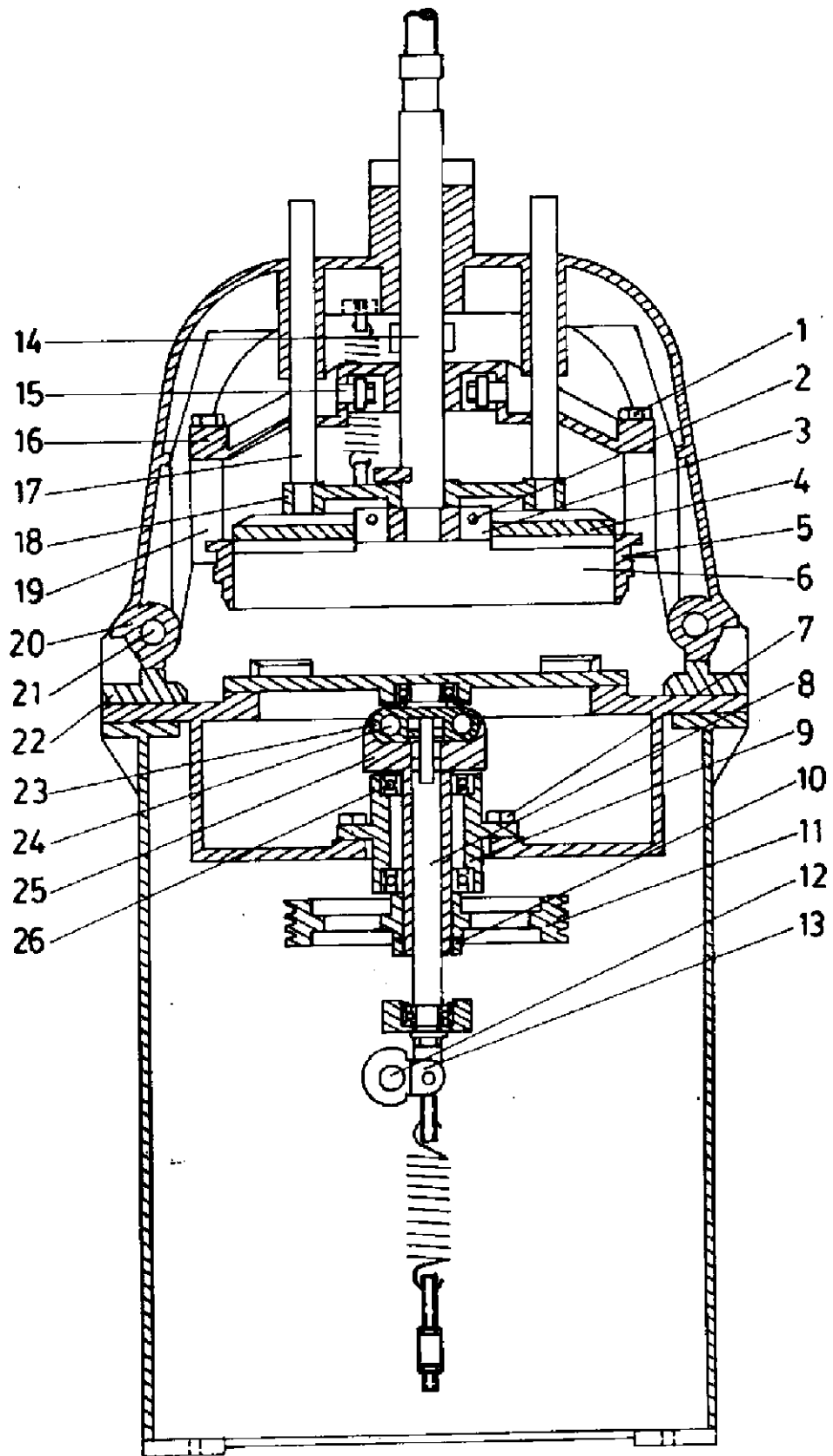

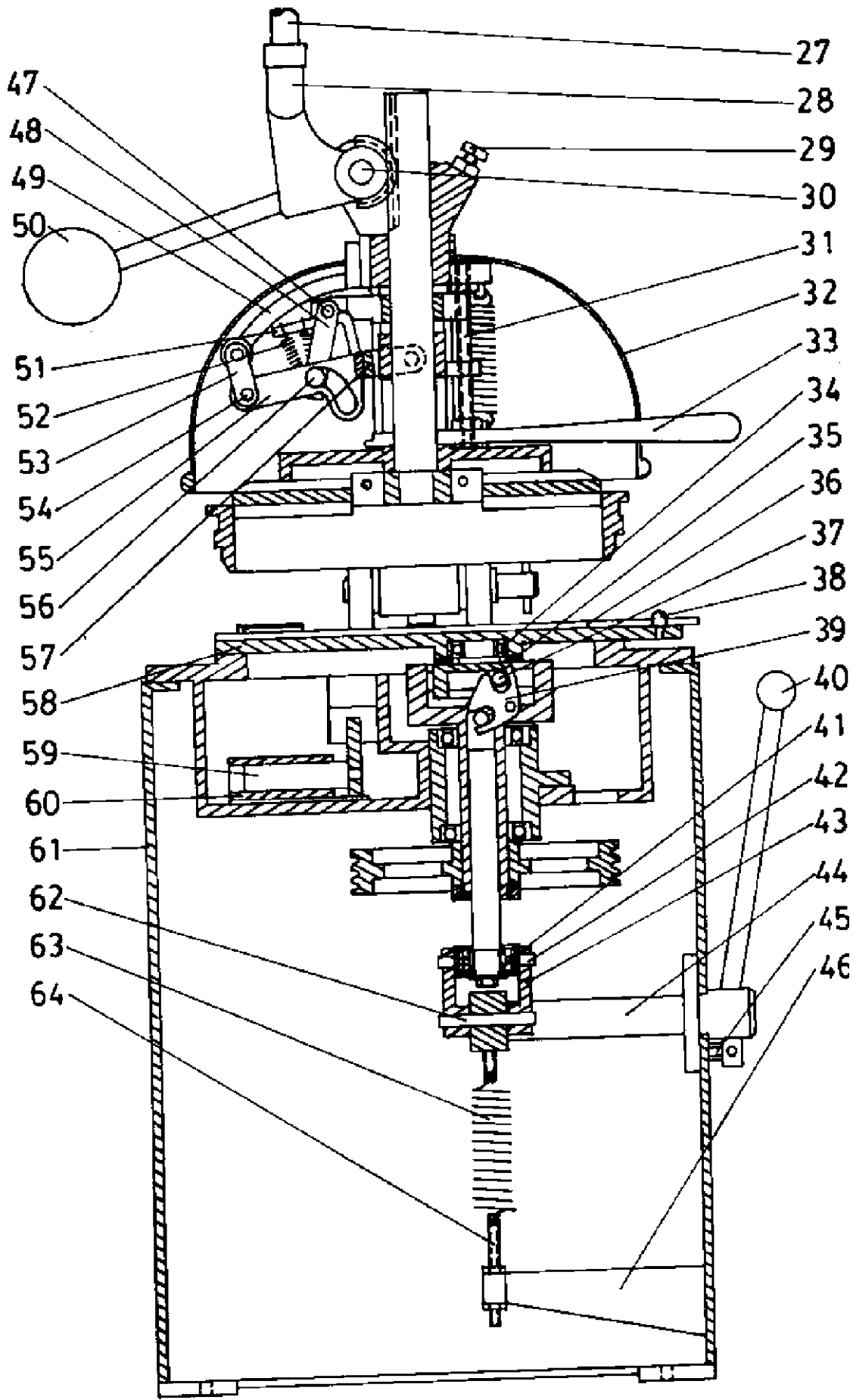

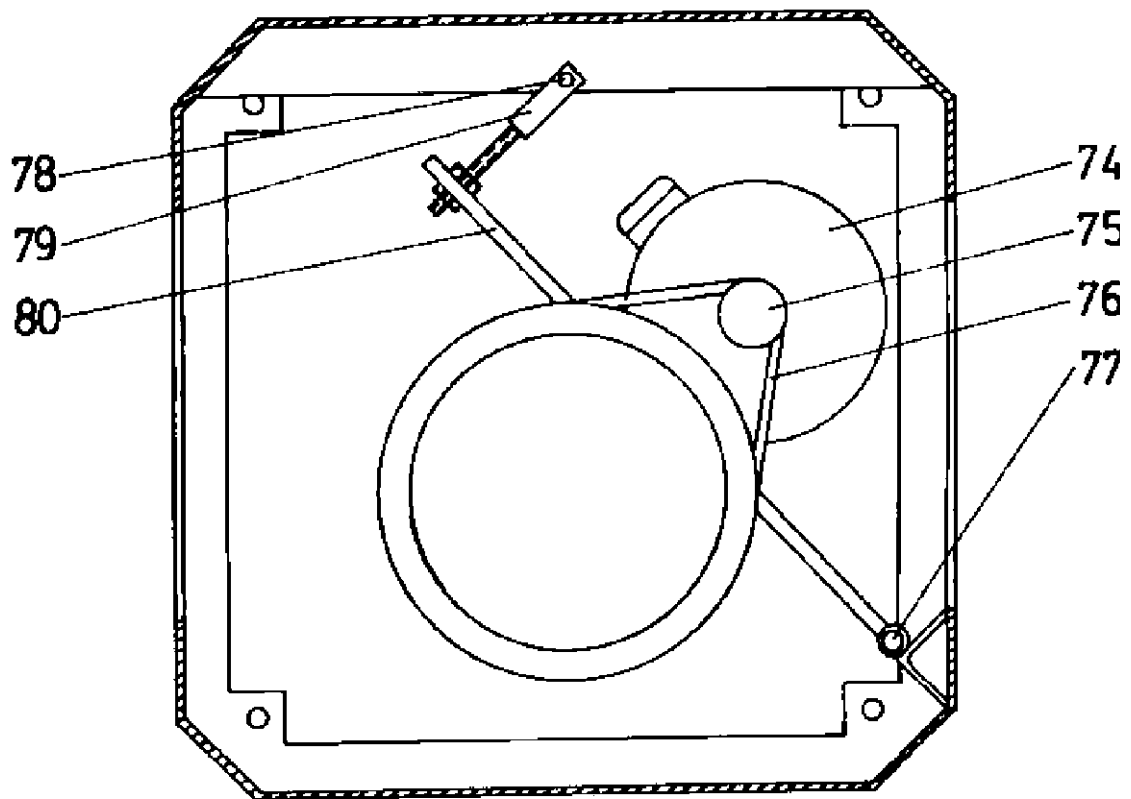
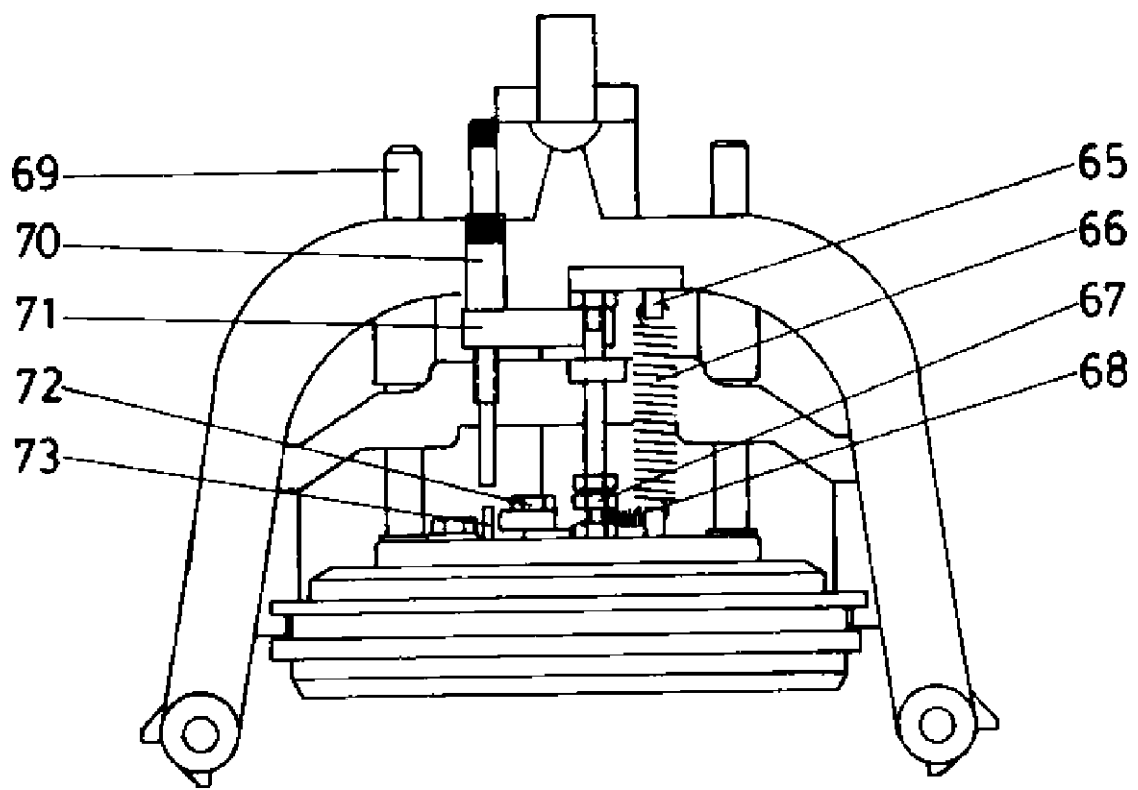

NO . DISIGNATION

1. SCREW
2. FITTING SCREW
3. CROSS PIECE
4. KNIFE HEAD
5. DOUGH CHECK RING
6. KNIFE
7. HEX-BOLT
8. PUSH BAR
9. FLANGE BEARING
10. SETTING RING
11. V-BELT PULLEY
12. SEITCHING SHAFT
13. LEVER
14. MAIN SHAFT
15. COLLAR SCREW
16. RING GUIDING BRIDGE
17. GUIDE SHAFT
18. FLANGE
19. HAMMER SCREW
20. STRAP
21. CLAMPING LEVER
22. BEARING BLOCK
23. SLIDE PIECE
24. GUIDE BOLT
25. BUSHING
26. BALL BEARING
27. PRESSING LEVER

NO . DISIGNATION

28. TOOTHED SEGMENT
29. HEX-BOLT
30. SEGMENTAL BOLT
31. ADJUSTING SCREW
32. FRONT COVER
33. BALL HANDLE
34. ROLL BEARING
35. BEARING CAP
36. PLASTIC PLATE
37. BOLT FOR ANGLE LEVER
38. PIN
39. ANGLE LEVER
40. MOULDING LEVER
41. ROLL BEARING
42. BOLT
43. BONNECTION PIECE
44. FLAGE BEARING
45. STOP BOLT
46. SUPPORT
47. SUPPORT PIN
48. LINK
49. SUPPORT BRACKET
50. BALANCE WEIGHT
51. SPRING STRAP
52. SPRING
53. CONNECTING JOINT BAR
54. PIN

NO . DISIGNATION

55. SUPPORT FORK
56. ROLLER FOR SUPPORT
PIN
57. SUPPORT STRAP
58. MOULDING PLATE
59. SLIDE
60. SLIDE BEARING
61. HOUSING
62. FASTENING BOLT
63. BALL HANDLE
64. SPRING BOLT
65. SPRING BOLT
66. TENSION SPRING
67. HEX-BOLT
68. TENSION SPRING
69. ADJUSTING SCREW
70. SLEEVE NUT
71. BRACKET
72. COLLAR SCREW
73. LIMITATION PIN
74. MOTOR
75. V-BELT PULLEY
76. V-BELT
77. SUPPORT PIN
78. HEX-BOLT
79. TENSION SCREW
80. MOTOR SUPPORT

0. ELECTRIC CONTROL DIAGRAM

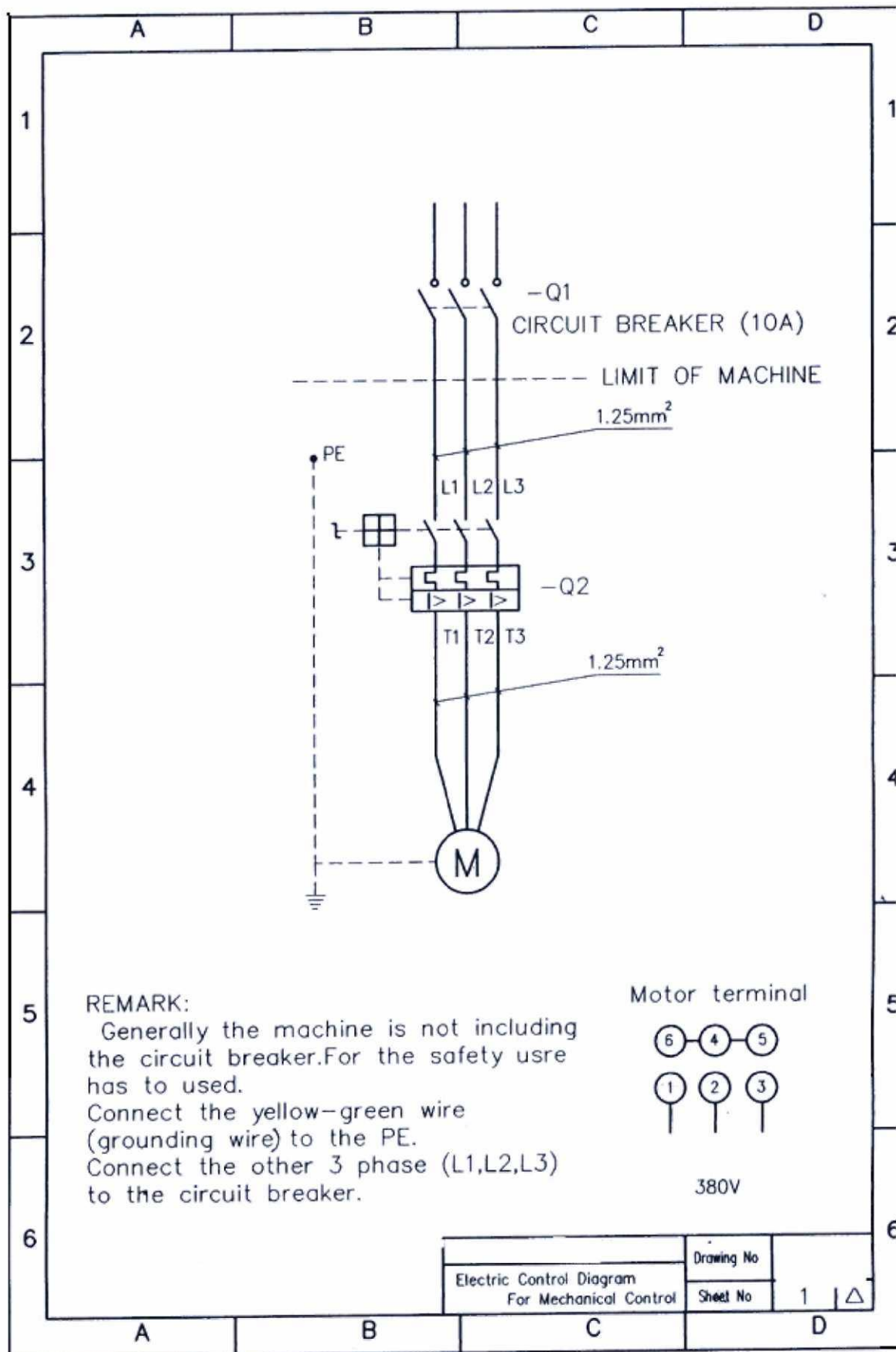

Warranty & Service

One year parts and labor limited warranty on most items, there are select items which carry a two year warranty. Extended warranty is available on some products. Contact us for details.

For all warranty claims, proof of purchase is required.

Warranty begins 10 days after shipping from warehouse; delays in installation which would extend the warranty must be approved.

All equipment must be installed and connected by qualified professionals in accordance with the manual specification.

Any abuse of equipment or improper use of machinery will void the warranty. Including failure to follow all instructions in operations manual. Properly install, maintain equipment, follow capacity charts, or electrical information.

Accessories, attachments, or electrical components such as fuses, bulbs, elements and switches are covered under a 90 day warranty. Repairs include Parts and Labor only, excluded is the following:

1. Overtime Labor Rates
2. Expedited Freight for Parts
3. BakeMax assumes no responsibility for down time or loss of product. All defective parts must be returned to BakeMax for credit. Repairs must be pre-authorized by BakeMax prior to work commencing.
4. Travel time is not covered by BakeMax, unless pre-authorized by BakeMax.

Bench Warranty (Machines Weighing 100 lb or less)

For all warranty claims proof of purchase is required to claim warranty. One year parts and labor warranty, from date of purchase.

Once machine is approved for warranty, the machine is to be shipped prepaid to authorized service depot. Customer will ship machine prepaid to authorized service depot. If machine requires warranty work in less than 30 days of purchasing BakeMax will pay all shipping charges. (Freight damages during shipping for warranty is the responsibility of the owner of the machine.)

Once machine is received and repaired it will be returned to the user at BakeMax expense.

*****BakeMax machines sold outside of the continental North America will carry one year parts warranty only.***

Titan Ventures International (TVI)
Toll Free: 1-800-565-BAKE (2253)
Telephone: 1-506-858-8990
Fax: 1-506-859-6929
Email: Info@BakeMax.com

BakeMax is a Registered Trade Mark of Titan Ventures International Inc.

BakeMax ® / Titan Ventures International Inc.

