



# **BakeMax BMHGG01 Titan Series Heated Self-Serve Display Case Operations Manual**



**Questions? OEM Parts, Contact Us:**

Toll Free: 1-800-565-2253

Email: [Info@BakeMax.com](mailto:Info@BakeMax.com)

[www.BakeMax.com](http://www.BakeMax.com)

**Warranty Registration**

[www.BakeMax.com/Warranty-Registration](http://www.BakeMax.com/Warranty-Registration)



# Warning & Safety

**PLEASE READ AND FOLLOW INSTRUCTIONS BELOW TO PREVENT INJURY OR DAMAGE TO THE PRODUCT**

BakeMax® (a registered trademark of Titan Ventures International Inc or TVI) is not responsible for any harm or injury caused due to any person's improper or negligent use of this equipment. The product shall only be operated by someone over the age of 18, of sound mind, and not under the influence of any drugs or alcohol, who has been trained in the correct operation of this machine, and is wearing authorized, proper safety clothing. This machine is intended for commercial use only. Any modification or miss use to the machine voids any warranty and may cause harm to individuals using the machine or in the area of the machine while in operation.

- When using the machine, please ensure that you have read all of the instructions within this manual.
- Be aware of your surroundings when using this machine, ensure there are no children or any other persons who are near the machine before operating.
- Do not put hand near moving parts.
- Remove all obstacles, which may interfere with machine functions.
- Keep work area clean and clear of clutter.
- Do not sit or stand on machine.
- Do not wear loose clothing or jewellery when operating machine as it may get caught in moving parts and cause injury.
- Stop using the machine and have it checked by an authorized service personal if it is not working properly.
- Disconnect from power source before performing and maintenance or cleaning on the machine.
- When the machine is not in use, please clean and store properly,
- Do not place any electrical parts or plug / cord in water or liquid.
- If the supply cord is damaged it must be replaced by an authorized service agent in order to avoid any electrical hazards.
- Keep power cord away from heat.
- Always ensure to follow local laws when operating your machine.

# Cleaning

- This unit has been coated for shipping purposes, please clean before use.
- Do not use any liquid pressurised cleaning equipment on this machine.
- Disconnect power supply before cleaning.
- Only use food grade non abrasive cleaning agents.
- Follow any additional cleaning / maintenance listed below.

# Features

Increase impulse sales by displaying your sandwiches, burgers, wraps, pizzas and more with the 31.5" wide BakeMax BMHGG01 Titan Series Self-Serve Heated Display Case. With its slanted shelf design for better product visibility and 1160 watts of heating power to maintain food safe temperatures. The BakeMax BMHGG01 is the ultimate grab and go display warmer for any convenience store, cafeteria, concession stand or other self-serve counter.

- Constructed with stainless steel, tempered glass sides and fixed rubber feet for extra durability.
- Adjustable thermostatic controls and temperature range of 30-90°C (86-194°F) to maintain food safe temperatures.
- Independent heat & light controls for each shelf to allow flexibility when merchandising a variety of foods.
- Two slanted shelves with adjustable divider rods allowing you to display a wide variety of foods. 8 rods included
- Merchandising / price tag strip
- 1 Year Limited Warranty

# Technical Specifications:

- Exterior Dimensions (WDH) 31.5" x 27.6" x 27.2"
- Net Weight 90.5 lb
- 120v / 10 Amps / 1160 W / 60Hz / 1Ph
- Nema 5-15P Plug

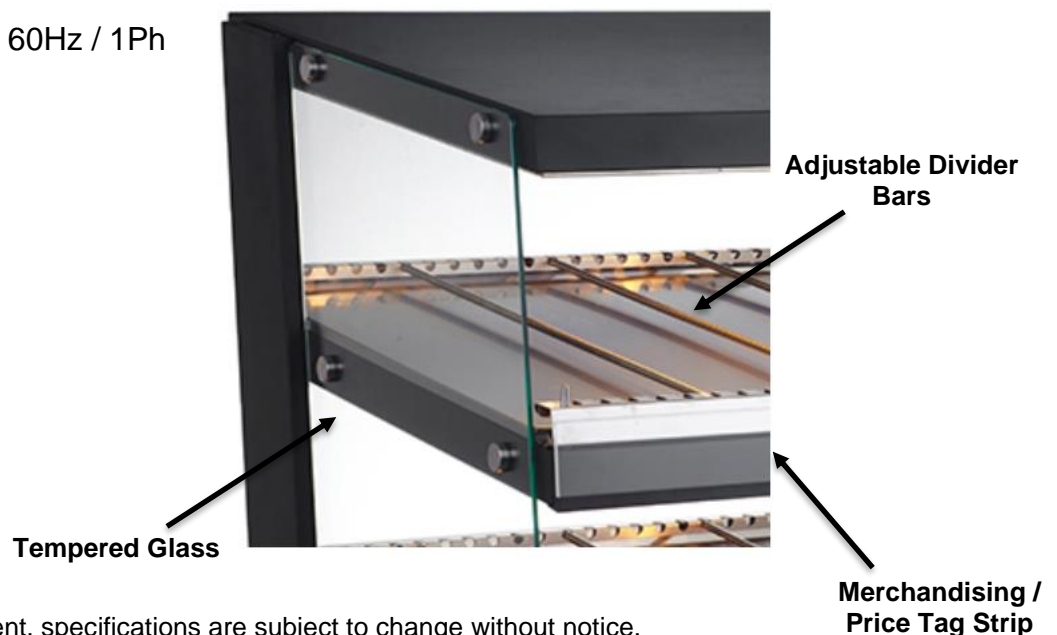

\*\* Due to continuous product improvement, specifications are subject to change without notice.

# Operation

## **To Start:**

1. Ensure unit is placed on a flat and stable surface.
2. Clean unit before plugging in and starting operation.
3. Do not change the plug on this unit as it will prevent the unit from working correctly and void all warranties.
4. Set the temperature as required for respective foods. You may adjust the desired temperature in the range between 30°C-90°C.
5. Allow the unit to reach desired temperature before placing cooked food inside.
6. Always use safety gloves or tongs when placing or removing food, as some of the warmer's parts become very hot.
7. Disconnect the warmer from the power outlet when the it is not in use.

# General Maintenance & Cleaning

1. Daily maintenance should be carried out with all power to the unit in the off position, and the electrical cord unplugged. Cleaning should be carried out by means of food grade cleaning solutions via a soft or damp cloth. Do not utilize any type of pressurized water equipment.
2. Do not use any acidic agents and make sure that no water enters the device.
3. After the cleaning procedure, you should use a soft and dry cloth to dry and polish the surface.
4. Make sure the device has been cleaned properly before storing it in a dry place.
5. Regular inspection on the outside and internal cabinet along with the power cord should be observed and carried out on a regular basis to isolate and or observe any unforeseen failure or safety concern.

# Electrical Schematic

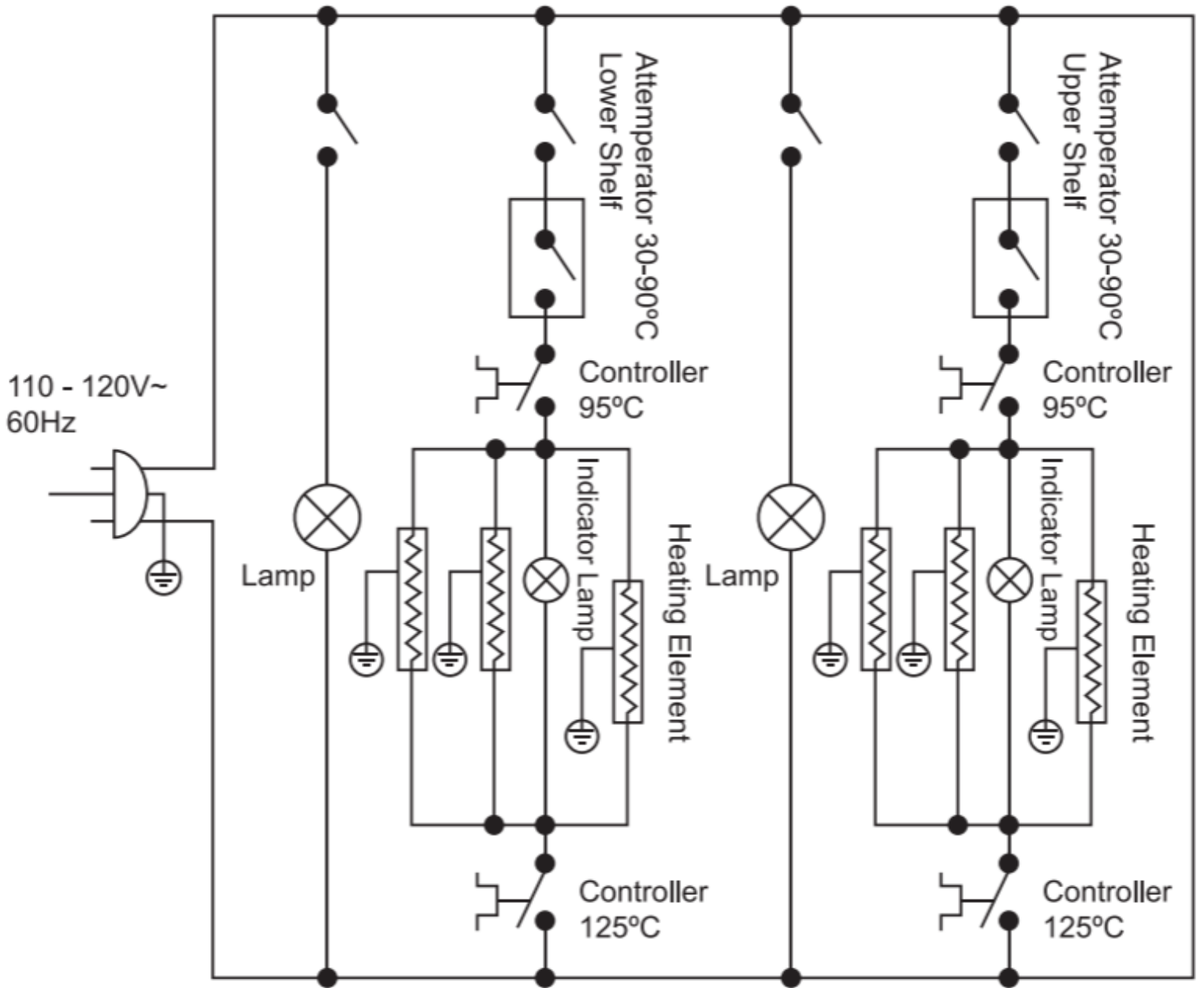

# Warranty & Service

---

One year parts and labor limited warranty on most items, there are select items which carry a two year warranty. Extended warranty is available on some products. Contact us for details.

For all warranty claims, proof of purchase is required.

Warranty begins 10 days after shipping from warehouse; delays in installation which would extend the warranty must be approved.

All equipment must be installed and connected by qualified professionals in accordance with the manual specification.

Any abuse of equipment or improper use of machinery will void the warranty. Including failure to follow all instructions in operations manual. Properly install, maintain equipment, follow capacity charts, or electrical information.

Accessories, attachments, or electrical components such as fuses, bulbs, elements and switches are covered under a 90 day warranty. Repairs include Parts and Labor only, excluded is the following:

1. Overtime Labor Rates
2. Expedited Freight for Parts
3. BakeMax assumes no responsibility for down time or loss of product. All defective parts must be returned to BakeMax for credit. Repairs must be pre-authorized by BakeMax prior to work commencing.
4. Travel time is not covered by BakeMax, unless pre-authorized by BakeMax.

## Bench Warranty (Machines Weighing 100 lb or less)

For all warranty claims proof of purchase is required to claim warranty. One year parts and labor warranty, from date of purchase.

Once machine is approved for warranty, the machine is to be shipped prepaid to authorized service depot. Customer will ship machine prepaid to authorized service depot. If machine requires warranty work in less than 30 days of purchasing BakeMax will pay all shipping charges. (Freight damages during shipping for warranty is the responsibility of the owner of the machine.)

Once machine is received and repaired it will be returned to the user at BakeMax expense.

***\*\*BakeMax machines sold outside of the continental North America will carry one year parts warranty only.***



Titan Ventures International (TVI)  
270 Baig Blvd, Suite A3, Moncton, NB E1E1C8  
Toll Free: 1-800-565-BAKE (2253)  
Telephone: 1-506-858-8990  
Fax: 1-506-859-6929  
Email: Info@BakeMax.com

*BakeMax is a Registered Trade Mark of Titan Ventures International Inc.*

---

## BakeMax ® / Titan Ventures International Inc.

### Warehouses:

270 Baig Blvd, Suite A3, Moncton, NB E1E1C8   
1605 Crescent Circle, Dallas, TX 75006 

**Toll Free:** 1-800-565-BAKE (2253)  
**Phone:** 506-858-8990  
**Fax:** 506-859-6929  
**Email:** Sales@BakeMax.com