



Operations Manual

BMPS001

Two Pass Pizza Sheeter



WARNING: PLEASE READ AND FOLLOW THE INSTRUCTIONS BELOW BEFORE OPERATING PRODUCT

- When using the machine, please confirm that you have read all the instructions within this manual.
- Beware of any child/children or any other persons who are near the machine before operating.
- Do not put hand near moving parts.
- Remove all obstacles, which may interfere with machine functions.
- Keep work area clean and clear of clutter.
- Do not sit or stand on machine
- Do not wear loose cloth or jewellery when operating machine as it may get caught in moving parts and cause injury
- When the machine is abnormal or broken, you should stop using and check it or have it checked by a professional.
- Disconnect from power source before performing maintenance on the machine.
- When machine is not in use, please clean and store properly.
- Do not place any electrical parts or plug/cord in water.
- The cord should be away from the heat.
- Don't hang out the cord on the desk or cabinet.
- Machine may have sharp or pointed edges, use caution when cleaning.
- This machine should only be operated by personnel who can read, understand and respect warnings and instructions regarding this machine and the manual.
- Keep this manual in a safe place for further and regular reference and ordering parts.
- Please write model serial and date of purchase of your machine in the space provided in case you will need to order parts in the future.
- Always work by security code of your country, state, province, city or committee of your work place.

INDEX

SAFETY -----	Page - 1
PRELIMINARY -----	Page - 2
Guarantee Shipment	
DESCRIPTION -----	Page - 3
Installation Connections	
WORKING -----	Page - 4
MAINTENANCE-----	Page - 5
DIAGRAMS	
Machinery-----	Page - 7
Spare Parts Diagram -----	Page - 11
Electrical Diagram -----	Page - 17

SAFETY

- a. Please review this manual in full before using as any miss use of the machine can result in injury or even death.

Any service work required must be carried out by an authorized service personal.

- d. During phases of research or removal of any cause of damage or inconvenience concerning the machine, take all necessary measures to prevent any damage to people or things. Disconnect from electrical outlet (separation of the machine from the electric network) before approaching the protective devices.
- e. It is absolutely forbidden to neutralize, remove, modify or in any other way render inefficient, any part of the safety devices, protective devices, or controls of the machine, wherever positioned. All the protective and safety devices must be kept in perfect condition and working order.
- f. Connecting ground with the machine. A terminal for connection of the external earth conductor is provided in the vicinity of the associated phase conductor terminals with marked "PE". It should make sure the "PE" terminal being connection before machine running.
- g. "SHUT OFF" the power before inspection, cleaning, maintenance and leaving the machine.
- h. At the end of any intervention that requires the removal or the neutralization of any component correlated to safety (barriers, sensors, protections, etc.) carry out the putting back into operation ensuring the correct position and effectiveness.

PRELIMINARY

With the help of this manual, the manufacturer provides all the technical elements necessary for a correct installation and working of the appliance. The user is responsible for following these instructions. The aspects concerning the protection of safety and the environment are also pointed out together with the characteristics, installation, and maintenance of the machine.

It is important to read this manual carefully before using the product, and whenever the need arises to consult it. Adhere to the technical instructions provided and follow all the indications scrupulously. For the safety of the operator, the devices of the machine should always be kept in good working order. This manual, an integral part of the machine, must be kept in an accessible place known to all OPERATORS, and made available to the authorized personnel for any eventual repairs and maintenance.

GUARANTEE

All equipment parts, except for the electric devices, are covered by a 12-months guarantee, provided that faults are due to manufacturing. The delivery of the above mentioned parts is to be paid by the receiver. Replacement of the entire equipment is not covered by guarantee.

SHIPMENT

Goods are shipped at buyer's risk. Any complaint about the faulty condition of cargo must be made to the carrier immediately after delivery. Please check that goods were not damaged during shipment and if so inform the carrier immediately after delivery. We are not liable for damage which was not reported to the carrier shortly after receiving the shipment.

DESCRIPTION

The BMPS001 was designed in accordance with American regulations and has been **manufactured** to protect the user from the risks connected to its use; for this reason, the machine is equipped, with special safety devices to avoid risks during contact with the moving parts.

Do not throw away the packing, separate it according to the type of material (e.g. cardboard, wood, plastic material, etc.) and dispose of them in conformity with the local and national laws in force.

INSTALLATION

a. Delivery

To delivery should be carried out by qualified person and pay attention to the balance of the machine. Do not make it upset or incline more than 30 degrees. Make sure the lifting strength of wire rope, hoist or forklift is enough to lift the machine.

Before positioning the machine, make sure that the bearing surface is at a horizontal level. And without sunlight directly or near heat source. Please put the machine in a well ventilated place and dust free. The ambient temperature should be from 5 to 45°C, relative humidity from 30% - 90%.

b. Connections

Connect the machine to the electric power supply, after having:

- Ensured that the tension and frequency of the power supply correspond to that written on the plate. Ensured that socket is connected to earth.
- Take steps to have the proper plug to a 4 pole wire (3 phase, neutral and earth) for triple phase versions, attached by specialized, capable personnel.

The manufacturer specifies that the mains line should be equipped with safety devices by a differential switch, coordinated with the general earth installation, in conformity' with the local and national laws. Check that the safety devices of the machine are present and assembled before activating the machine.

The machine is equipped with fixed suitable safety devices designed to avoid contact between parts of the human body (upper limbs) and parts of the machine in movement during processing phases, in order to eliminate risks of dragging, crushing and abrasion.

WORKING

- a. Never use machine while wearing loose clothes, ties, scarves and etc which may have the potential to be dragged into Roller
- b. Ensure Top Lid is closed and Safety Switch is engaged, otherwise machine will not start.
- c. Adjust Top set of Rollers to desired gap that is approximately 50% greater than Bottom Roller Gap. Adjustment for Top Roller is by means of the left side adjustment Handle. Ensure Handle is locked in place to eliminate movement under load. This can be viewed from horizontal exit opening near Top Plate - #048.
- d. Adjust Bottom Roller by the Right Lever by viewing Roller Gap in space directly above the stainless steel plate - #031
- e. Press Start Button.
- f. Place Dough Ball (slightly squashed) in Top Stainless Chute, this will then exit as a flat oval base. Note: Fingers or hands should never be forced into this Chute as dangerous Rollers are at the base.
- g. Place on top of Stainless Plate - #052 after turning base 90% and insert into second opening. Note fingers must not be forced inside this space as the Rollers can pull anything into the machine.
- h. Pizza Base now delivered on Conveyor Belt - #202. Remove and place on Pan.
- i. Push Stop Button to stop machine. By lifting Top Lid # machine will automatically stop.

Working Irregularities

Problem: The motor stops

- a. The thermic motor protector safety device has discovered overheating of the electric motor.

Remedies: Wait for about 30 min to allow the motor to cool; then restart the process.

- b. Malfunction and/or breakage of any electric component.

Remedies: Contact the retailers authorized qualified technician.

Problem: Incorrect installation of machine

- a. *Check the power tension and the frequency should be those stated on the plate.*
- b. *Do not remove the safety devices when the machine is in use.*
- c. *The socket must be connected to earth.*
- d. *Don't open the tension without having unplugged the machine first.*

MAINTENANCE

- a. Lift Top Panel - #0531 and wipe Rollers and internal sections with damp cloth and with a brush remove dough & flour from Scrapers. Ensure that there is no dough left between Scraper & Rollers.

Note: Scrapers can be rotated by a few degrees to make cleaning easier.

Close lid, push Start Button and immediately Stop Button. Reopen Lid and clean remainder of Roller and Scrapers. Repeat this until full circumference of Roller is cleaned.

- b. No. 4 Scraper on the Bottom Roller is accessed from the Front Inspection Plate - #032 which has to be removed by 4 Thumb Screws - #033.

Note: Never use machine with this plate removed.

- c. Wipe machine daily with warm damp cloth to remove excess flour and dough. Chemical products should not be used on ABS white sheet material.

Note: Never try to insert cloth & rags into the machine for cleaning as they not only damage the machine but may also cause your hands to be drawn into the machine.

Never leave the machine running while unattended.

Check item as follows:

- Check noise and ventilation

- Check push buttons and switch

- Check protective earth wires

- Check the belt of elasticity

Check safety devices for any eventual repairs, contact exclusively a service center authorized by the manufacturer and ask for the use of original spare parts.

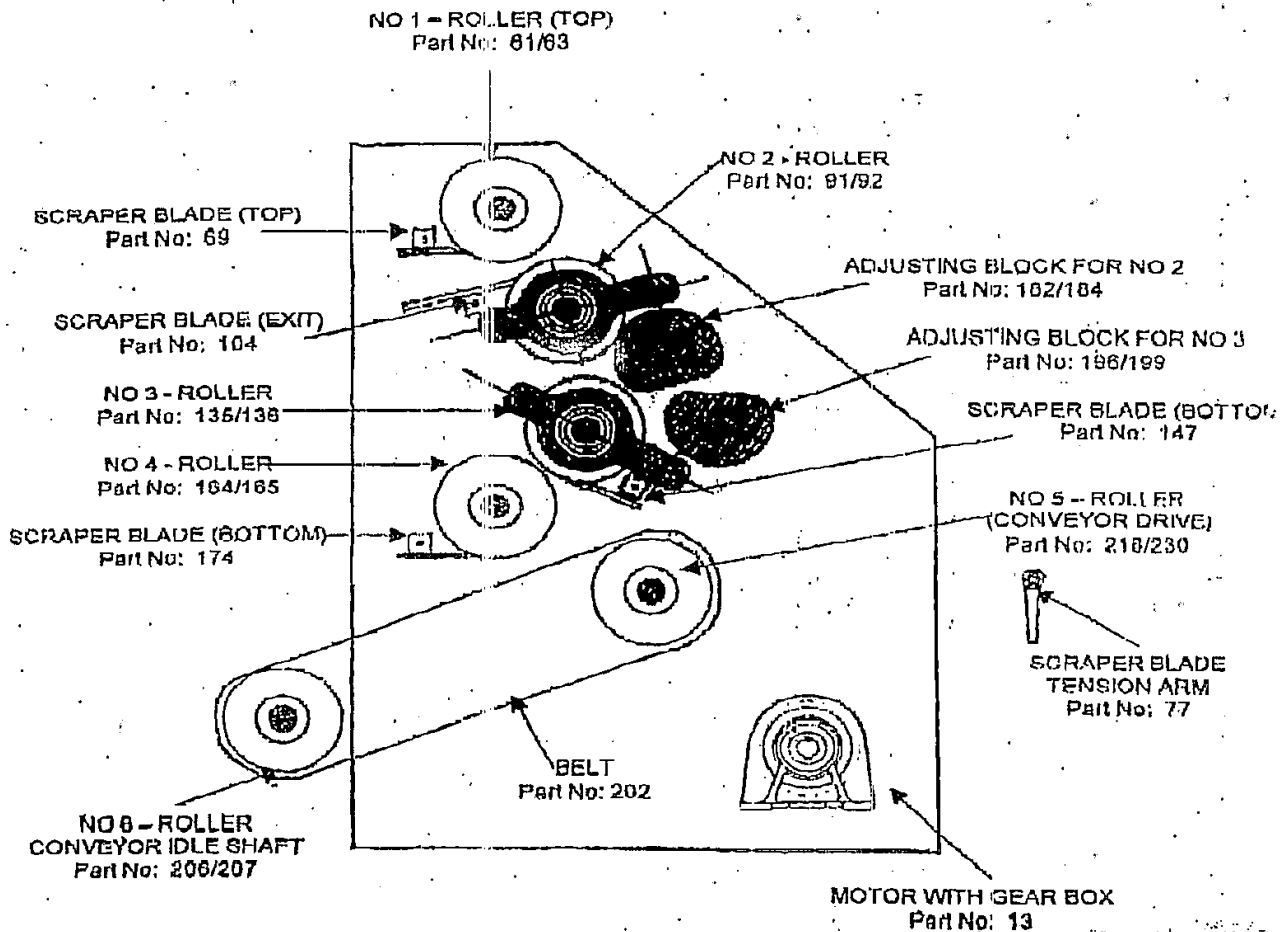
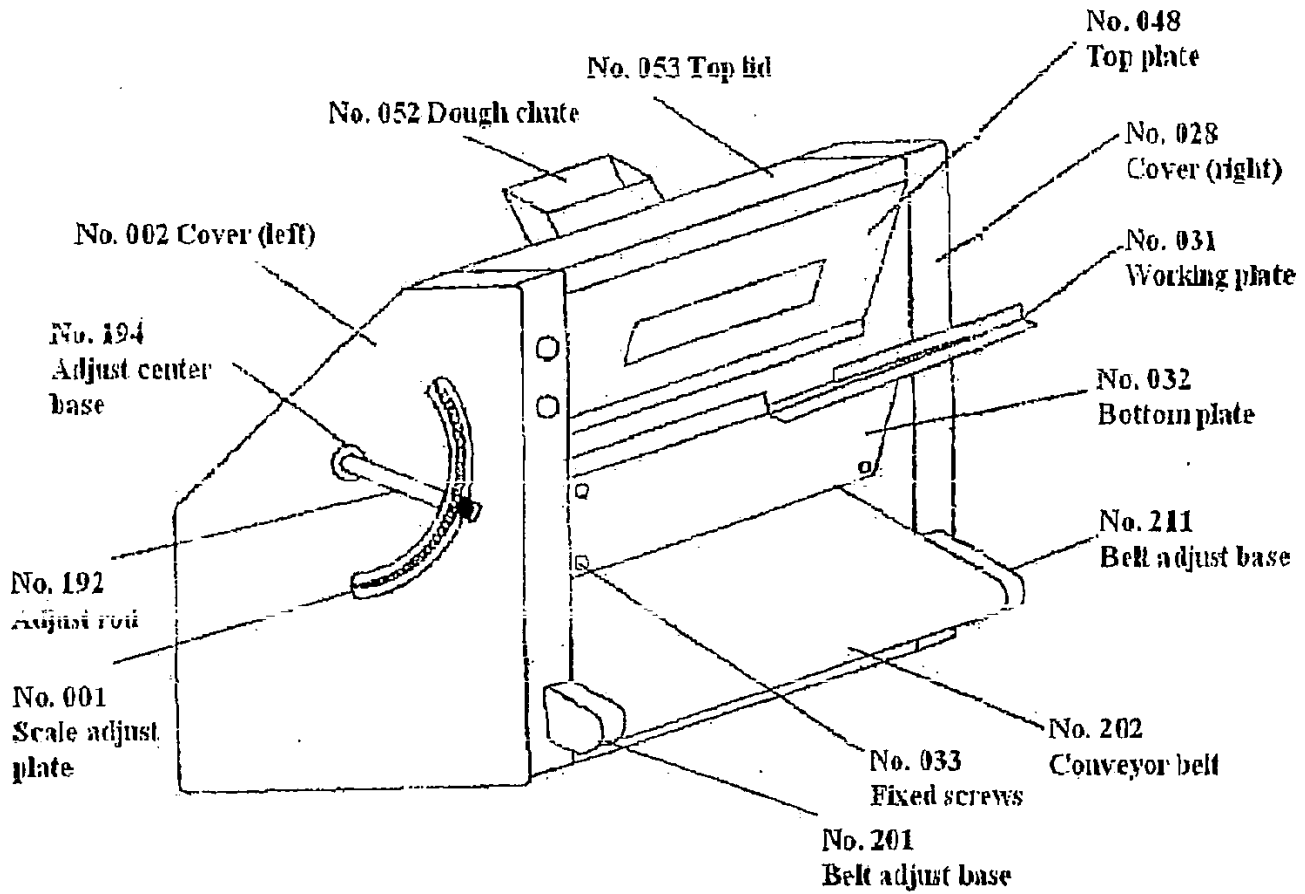

Warranty & Service

One year parts and labor limited warranty on most items, there are select items which carry a two year warranty. Extended warranty is available on some products. Contact us for details.

For all warranty claims, proof of purchase is required.

Warranty begins 10 days after shipping from warehouse; delays in installation which would extend the warranty must be approved.

All equipment must be installed and connected by qualified professionals in accordance with the manual specification.

Any abuse of equipment or improper use of machinery will void the warranty. Including failure to follow all instructions in operations manual. Properly install, maintain equipment, follow capacity charts, or electrical information.

Accessories, attachments, or electrical components such as fuses, bulbs, elements and switches are covered under a 90 day warranty. Repairs include Parts and Labor only, excluded is the following:

1. Overtime Labor Rates
2. Expedited Freight for Parts
3. BakeMax assumes no responsibility for down time or loss of product. All defective parts must be returned to BakeMax for credit. Repairs must be pre-authorized by BakeMax prior to work commencing.
4. Travel time is not covered by BakeMax, unless pre-authorized by BakeMax.

Bench Warranty (Machines Weighing 100 lb or less)

For all warranty claims proof of purchase is required to claim warranty. One year parts and labor warranty, from date of purchase.

Once machine is approved for warranty, the machine is to be shipped prepaid to authorized service depot. Customer will ship machine prepaid to authorized service depot. If machine requires warranty work in less than 30 days of purchasing BakeMax will pay all shipping charges. (Freight damages during shipping for warranty is the responsibility of the owner of the machine.)

Once machine is received and repaired it will be returned to the user at BakeMax expense.

*****BakeMax machines sold outside of the continental North America will carry one year parts warranty only.***

Titan Ventures International (TVI)
Toll Free: 1-800-565-BAKE (2253)
Telephone: 1-506-858-8990
Fax: 1-506-859-6929
Email: Info@BakeMax.com

BakeMax is a Registered Trade Mark of Titan Ventures International Inc.

BakeMax ® / Titan Ventures International Inc.