



www.BakeMax.com

Project: _____

Item: _____

Qty: _____ Date: _____

BakeMax BMDN1712R Electric Shawarma Machine

Achieve authentic results with precision grilling and slicing with a BakeMax Shawarma Machine. Designed for Mediterranean restaurants, kebab establishments & mobile food vendors, our robust and customizable equipment ensures efficient preparation of tender, flavorful shawarma and doner kebabs. Deliver exceptional quality that consistently satisfies your customers.



Features:

- Constructed of Heavy Duty Stainless-Steel
- Hygienic, Safe to use & Easy-to-Clean
- Ensures precise heat distribution for perfect gyros, doner kebab, shawarma, and al pastor.
- 100lbs. Meat Capacity
- Spit Length is 28" / 713mm
- Two Individually Controlled Fast-Heating Elements providing a total of 5000W of Power
- Large base provides a strong and reliable support
- Adjustable, Dual Directional Spit
- Sliding bottom housing allows you to get the shawarma meat closer to the element.
- Large Easy-to-Remove Grease / Oil Drip Container for Easy Clean-Up
- Includes Shovel to Catch Meat when Cutting
- Field Convertible to Single Phase
- 2-Year Limited Warranty



Intertek

Intertek

Electrical Specifications:

- 208V / 21A / 5000W / 60Hz / 3Ph / Hard Wired
- 208V / 24A / 5000W / 60Hz / 1Ph / Hard Wired

Product Specifications:

- Dimensions (WDH): 20" x 24" x 40"
- Weight: 75 lbs.

Shipping Specifications:

- Dimensions (WDH): 22" x 26" x 42"
- Weight: 89 lbs.

*Due to continuous product improvement, specifications are subject to change without notice.

BakeMax® / Titan Ventures International Inc.

Warehouses:

20 Caribou St, Moncton, NB E1H 0P3

5705 Valley Belt Rd Independence, OH 44131

1201 E 27th Terrace Pittsburg, KS 66762

Toll Free: 1-800-565-BAKE (2253)
Phone: 506-858-8990
Fax: 506- 859-6929
Email: Sales@BakeMax.com



www.BakeMax.com

Project: _____

Item: _____

Qty: _____ Date: _____

BakeMax BMDN1712R Electric Shawarma Machine

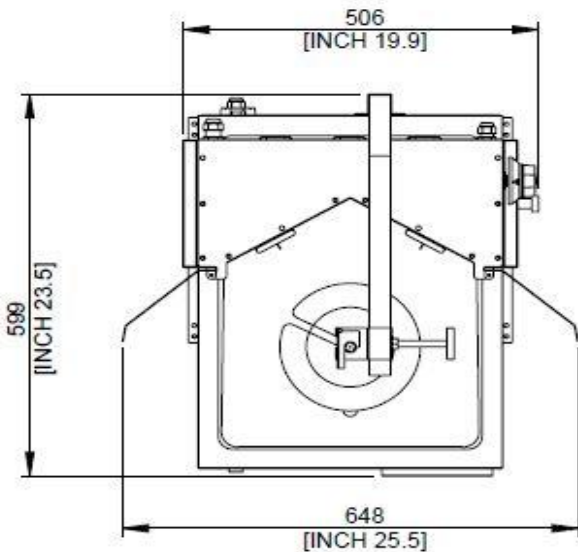
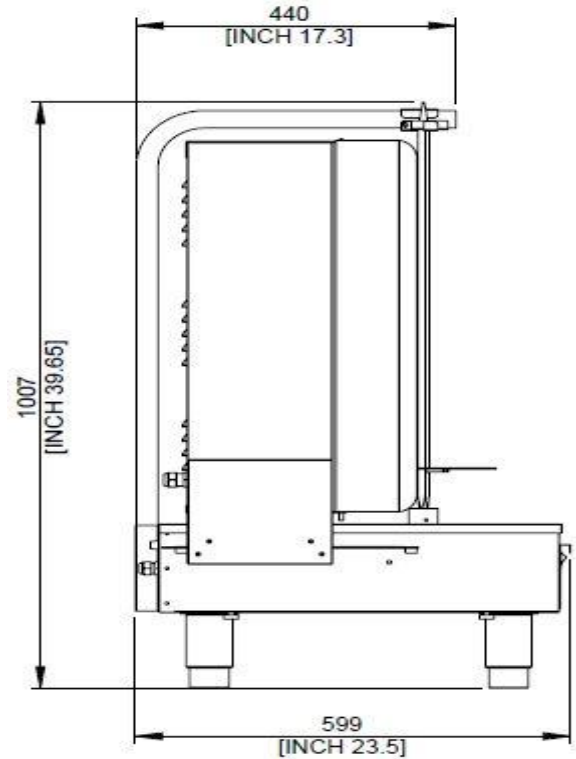
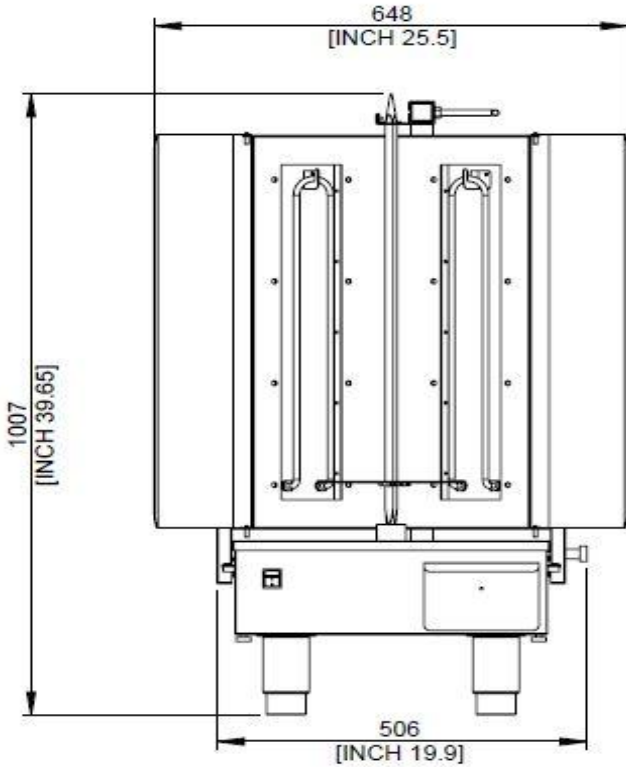



REQUIRED CLEARANCES

	NON-COMBUSTIBLE	COMBUSTIBLE
LEFT	0"	12"
RIGHT	0"	12"
BACK	0"	3"

BakeMax® / Titan Ventures International Inc.

Warehouses:

20 Caribou St, Moncton, NB E1H 0P3 
 5705 Valley Belt Rd Independence, OH 44131 
 1201 E 27th Terrace Pittsburg, KS 66762 

Toll Free: 1-800-565-BAKE (2253)
Phone: 506-858-8990
Fax: 506- 859-6929
Email: Sales@BakeMax.com