



www.BakeMax.com

Project: _____

Item: _____

Qty: _____ Date: _____

BakeMax BMHA01Y 18" Countertop Two Pass Dough Sheeter

The BakeMax BMHA01Y Countertop Double Pass 18" Dough Sheeter is an efficient and attractive two stage machine featuring a front infeed and discharge. Sheets up to 18" diameter bread & pizza dough.



Features:

- Heavy Duty and Easy-to-Clean all Stainless-Steel Construction including Roller Guards for increased Durability
- Includes Two sets of Non-Stick Delrin Roller Assemblies
- Adjust Dough Thickness and Diameter
- Emergency Stop Button
- Rolling Thickness: 0mm - 4.76mm
- A Single Operator can make approximately 400 Pieces Per Hour
- Plug & Go Nema 5-15P Plug
- 2-Year Limited Warranty

Product Specification:

- Dimensions (WDH): 23.6" x 18.1" x 31.8"
- Roller Size: 460mm / 46cm / 18.1"
- Product Weight: 95 lbs.

Shipping Specification:

- Dimensions (WDH): 34" x 23" x 34"
- Shipping Weight: 111 lbs.

Electrical Specifications:

- 110V / 2.5A / 370W / 60Hz / 1Ph / 5-15P



Intertek Intertek

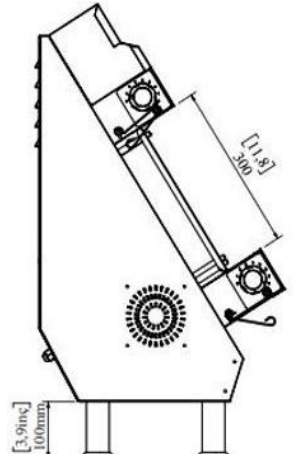
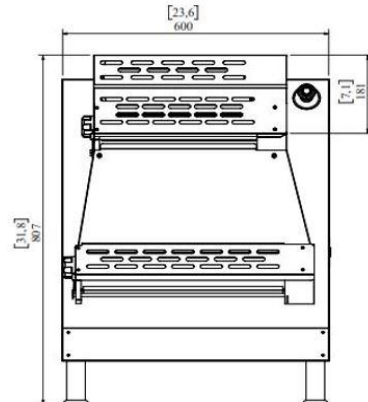
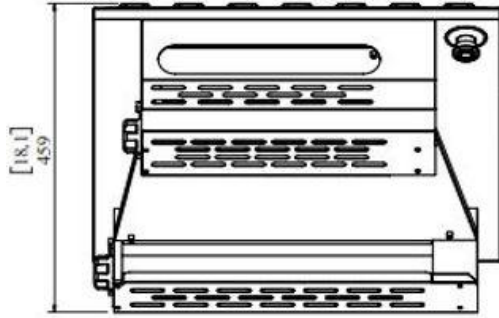
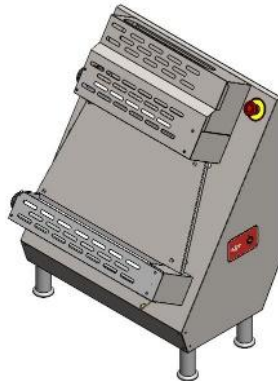

**Due to continuous product improvement, specifications are subject to change without notice.

BakeMax® / Titan Ventures International Inc.

Warehouses:

- 20 Caribou St, Moncton, NB E1H 0P3
- 5705 Valley Belt Rd Independence, OH 44131
- 1201 E 27th Terrace Pittsburg, KS 66762

Toll Free: 1-800-565-BAKE (2253)
Phone: 506-858-8990
Fax: 506- 859-6929
Email: Sales@BakeMax.com