

## BakeMax BMHA04 Countertop Single Pass 18" Dough Sheeter

The BakeMax BMHA04 Dough Sheeter features two non-stick rollers which allows you to quickly stretch and sheet dough up to 18.11" in diameter. It is a compact machine, which can save you space by allowing you to place it on a countertop. Comes standard with a safety guard to protect the operator when using the machine.



### Features:

- Heavy Duty and Easy-to-Clean all Stainless-Steel Construction including Roller Guards for increased Durability
- Includes One set of Non-Stick Delrin Roller Assemblies
- Sheets Dough from 0mm to 4.76mm thicknesses and up to 18.11" in Diameter
- Emergency Stop Button
- Production of up to 300 Pieces Per Hour
- Plug & Go Nema 5-15P Plug
- 1-Year Limited Warranty

### Product Specification:

- Dimensions (WDH): 24.4" x 15.7" x 14.4"
- Roller Size: 460mm / 46cm / 18.11"
- Product Weight: 48.5 lbs. / 22kg

### Shipping Specification:

- Dimensions (WDH): 26" x 17" x 16"
- Shipping Weight: 60 lbs. / 27kg

### Electrical Specifications:

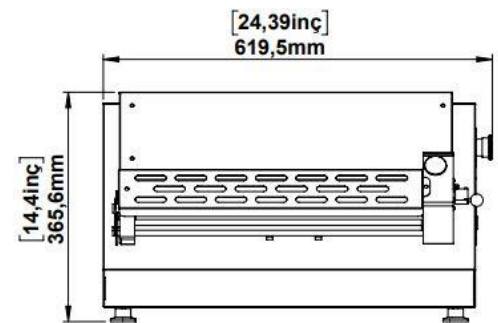
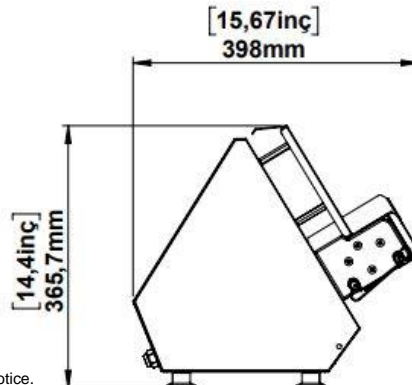
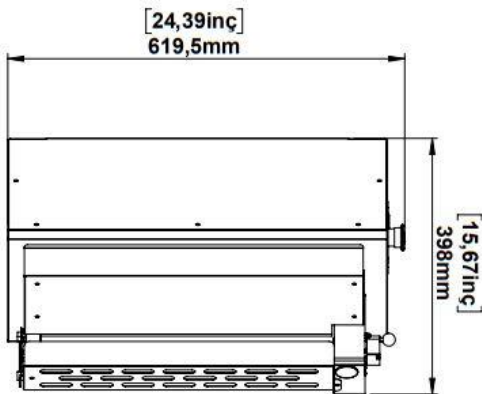

- 110V / 2.5A / 370W / 60Hz / 1Ph / 5-15P



\*Due to continuous product improvement, specifications are subject to change without notice.

**BakeMax® / Titan Ventures International Inc.**

### Warehouses:

20 Caribou St, Moncton, NB E1H 0P3   
5705 Valley Belt Rd Independence, OH 44131   
1201 E 27th Terrace Pittsburg, KS 66762 

Toll Free: 1-800-565-BAKE (2253)

Phone: 506-858-8990

Fax: 506- 859-6929

Email: Sales@BakeMax.com