



www.BakeMax.com

Project: _____

Item: _____

Qty: _____ Date: _____

BakeMax BMHA05 Countertop Single Pass 12" Dough Sheeter

The BakeMax BMHA05 Dough Sheeter features two non-stick rollers which allows you to quickly stretch and sheet dough up to 11.81" in diameter. It is a compact machine, which can save you space by allowing you to place it on a countertop. Comes standard with a safety guard to protect the operator when using the machine.



Features:

- Heavy Duty, Hygienic & Easy-to-Clean Stainless-Steel Construction including Roller Guards for Increased Durability
- Includes One set of Non-Stick Delrin Roller Assemblies
- Sheets Dough from 0mm to 4.76mm Thicknesses and up to 11.81" in Diameter
- Emergency Stop Button
- Production of up to 300 Pieces Per Hour
- Plug & Go Nema 5-15P Plug
- 1-Year Limited Warranty

Product Specification:

- Dimensions (WDH): 17.6" x 15.7" x 14.4"
- Roller Size: 300mm / 11.81"
- Product Weight: 41.8 lbs. / 19 kg

Shipping Specification:

- Dimensions (WDH): 18" x 16" x 15"
- Shipping Weight: 53 lbs. / 24 kg

Electrical Specifications:

- 110V / 2.5A / 370W / 60Hz / 1Ph / 5-15P

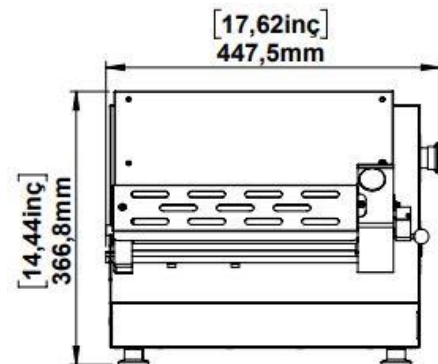
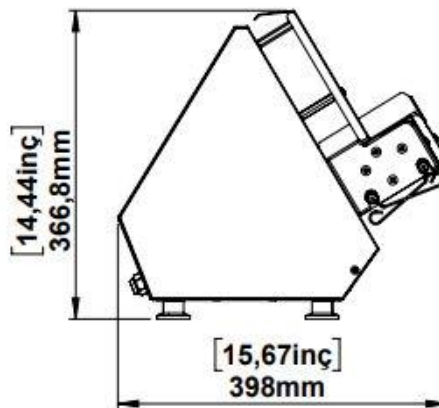
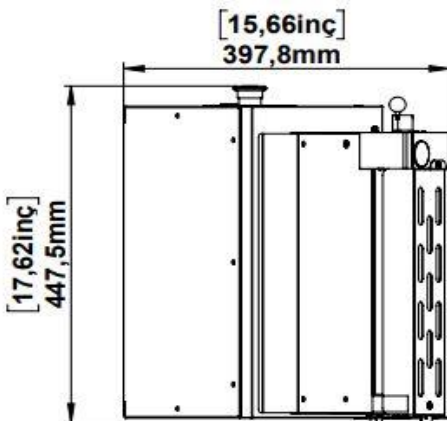

**Due to continuous product improvement, specifications are subject to change without notice.

BakeMax® / Titan Ventures International Inc.

Warehouses:

20 Caribou St, Moncton, NB E1H 0P3
 5705 Valley Belt Rd Independence, OH 44131
 1201 E 27th Terrace Pittsburg, KS 66762

Toll Free: 1-800-565-BAKE (2253)
 Phone: 506-858-8990
 Fax: 506- 859-6929
 Email: Sales@BakeMax.com