

BakeMax[®]
Titan Series
www.BakeMax.com

BMMG005 Meat Grinder Operations Manual



Questions? OEM Parts?

Contact Us:

Toll Free: 1-800-565-2253

Email: Info@BakeMax.com

www.BakeMax.com



Warning & Safety

PLEASE READ AND FOLLOW INSTRUCTIONS BELOW TO PREVENT INJURY OR DAMAGE TO THE PRODUCT

BakeMax® (a registered trademark of Titan Ventures International Inc or TVI) is not responsible for any harm or injury caused due to any person's improper or negligent use of this equipment. The product shall only be operated by someone over the age of 18, of sound mind, and not under the influence of any drugs or alcohol, who has been trained in the correct operation of this machine, and is wearing authorized, proper safety clothing. This machine is intended for commercial use only. Any modification or miss use to the machine voids any warranty and may cause harm to individuals using the machine or in the area of the machine while in operation.

- When using the machine, please ensure that you have read all of the instructions within this manual.
- Be aware of your surroundings when using this machine, ensure there are no children or any other persons who are near the machine before operating.
- Do not put hand near moving parts.
- Remove all obstacles, which may interfere with machine functions.
- Keep work area clean and clear of clutter.
- Do not sit or stand on machine.
- Do not wear loose clothing or jewellery when operating machine as it may get caught in moving parts and cause injury.
- Stop using the machine and have it checked by an authorized service personal if it is not working properly.
- Disconnect from power source before performing and maintenance or cleaning on the machine.
- When the machine is not in use, please clean and store properly,
- Do not place any electrical parts or plug / cord in water or liquid.
- If the supply cord is damaged it must be replaced by an authorized service agent in order to avoid any electrical hazards.
- Keep power cord away from heat.
- Always ensure to follow local laws when operating your machine.

Cleaning

- This unit has been coated for shipping purposes, please clean before use.
- Do not use any liquid pressurized cleaning equipment on this machine.
- Disconnect power supply before cleaning.
- Only use food grade nonabrasive cleaning agents.
- Follow any additional cleaning / maintenance listed below.

BMMG005 Features

Prepare freshly ground meat with ease using the BakeMax BMMG005 Meat Grinder. Capable of up to 1100 lbs. of meat per hour with its 2 HP motor. This unit is great for Restaurants, Delis, and Meat Shops.

Features:

- Powerful 2HP Motor.
- Grind up to of 1100 lbs. of Meat per Hour
- #32 Hub
- 2 Meat Plates Included (5mm & 8mm)
- Meat Pusher Included
- Constructed of Anodized Aluminum & Stainless Steel
- On / Off Switch
- Overload with Reset to Protect Motor
- 110V / 1500W / 60HZ / 1PH
- Plug & Go Nema 5-15P
- 1-Year Limited Warranty

Product Specification:

- Product Dimensions (WDH): 20.8" x 10.7" x 23"
- Product Weight: 57 lbs.

Shipping Specification:

- Packaged Dimensions (WDH): 24" x 12" x 26"
- Packaged Weight: 66 lbs.



Overload with Reset to
Protect Motor



Meat Stuffer Included



2 Plates Included (5mm & 8mm)
Additional Accessories Available Upon Request

General Components

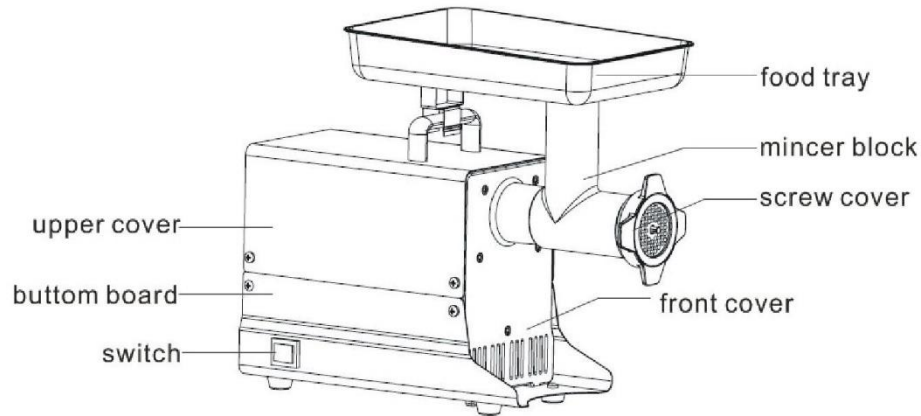

Operation

IMPORTANT: Before connecting your unit to your power supply, be sure your machine's electrical specifications, printed on the unit's nameplate, match those of your local power.

1. For first-time use, remove the grinder head and wash parts thoroughly.
2. Ensure all components are securely in place before use.
3. Mount the screw feeder, blade and disk, and then screw on the lock nut.

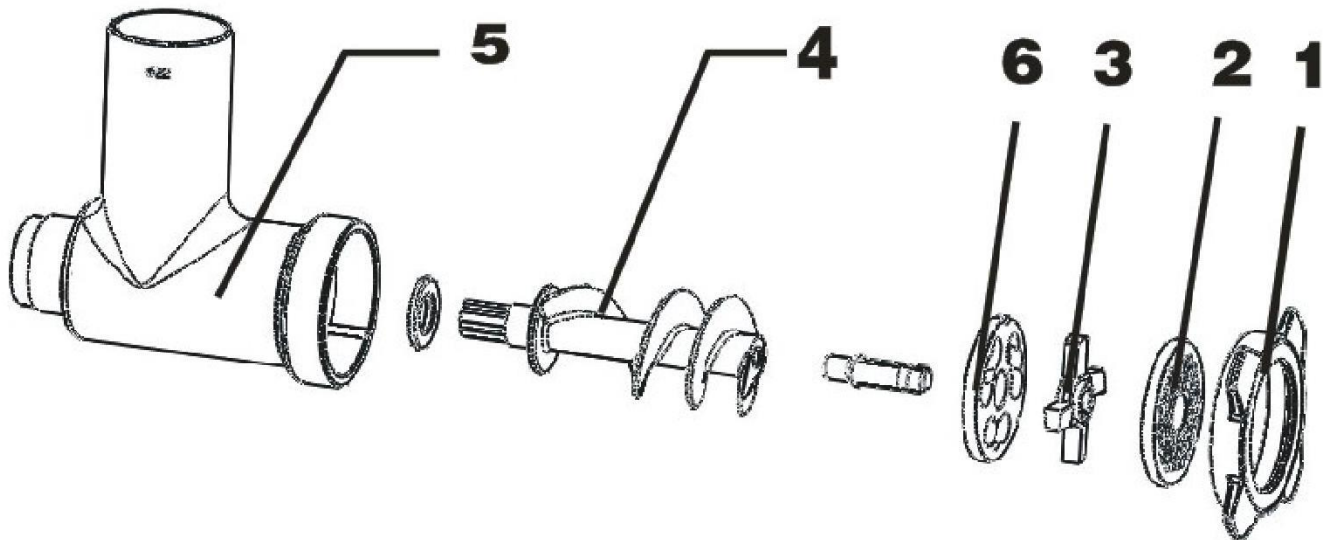

4. Install shell (fig 5) into body and install the knob into the hole of the front cover.
5. Install screw feeder (fig4) into shell and make sure the placement of knob is right.
6. Install knife on screw feeder and then install blade(fig 2)
7. All the components are fixed by the mincer block to ensure safety.

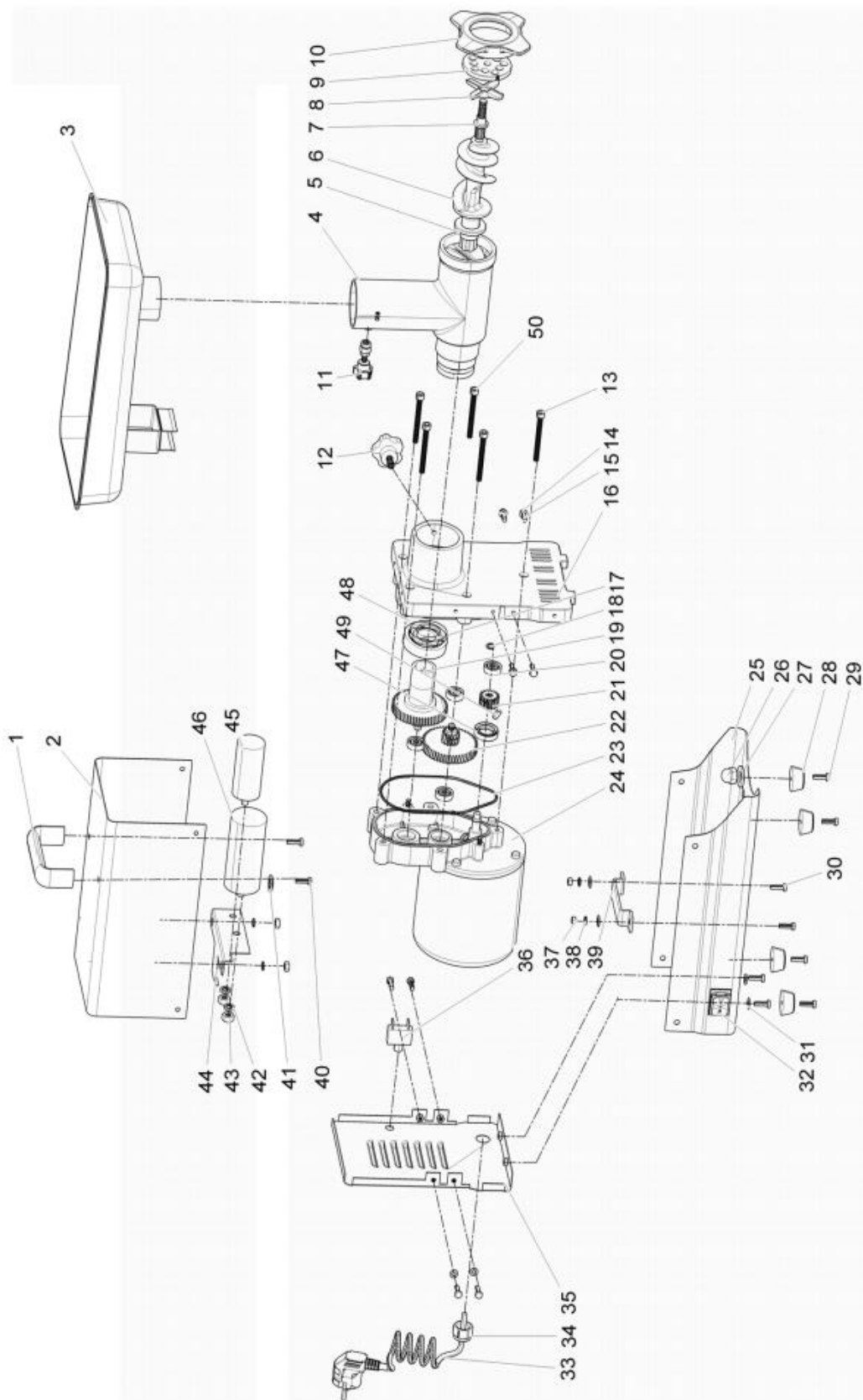

- 1.Handle
- 2.Top Cover
- 3.Meat Tray
- 4.Input Shell
- 5.Nylon Gasket
6. Feeder
- 7.Blade Axis
- 8.Blade
- 9.Plate
- 10.Screw Cap
- 11.Tray Knob
- 12.Cover Knob
- 13.Cap Screw
- 14.Hex Bolt
- 15.Gasket
- 16.Front Cover
17. Bearing
18. Ring
19. Spindle
20. Bearing
21. Small Gear
22. Double Gear
23. O Ring
24. Motor
25. Bottom
26. Ball Nut
27. Gasket
28. Leg
29. Bolt
30. Hex Bolt
31. Gasket
32. Switch
33. Wire & Plug
34. Power Cord
35. Back Cover
36. Overheat Switch
37. Nut
38. Gasket
39. Motor Support
40. Hex Bolt
41. Gasket
42. Gasket
43. Nut
44. Fixing Support
45. Start Capacitor
46. Run Capacitor
47. Oil Seal
48. Oil Seal
49. Key
50. Cap Screw
51. Meat Pusher

Warranty & Service

BakeMax provides a 1-Year Limited Parts and Labor warranty on most items, there are select items which carry a Limited 2-Year Warranty. Extended Warranty is available on some products. Please contact us for details. The Warranty is not transferable and is limited to original installation of equipment sold by BakeMax for the original user.

For all Warranty Claims, Proof of Purchase and/or Serial Number is required. Once the machine is approved, BakeMax will provide our customers with on-site Warranty Coverage on all equipment more than 100lbs. BakeMax assumes no responsibility for down time or loss of product. Repairs must be Pre-Authorized by BakeMax and have a Service Authorization Number issued prior to commencing Warranty Service.

Warranty begins 10-Days after shipping from warehouse; delays in installation which would extend the Warranty must be Approved. All equipment must be installed and connected by Qualified Professionals in accordance with the Manual Specification. Products shipped are to be inspected at time of delivery, the receiver is responsible for inspection.

Any abuse or improper use of the equipment will void the warranty. This includes failure to follow all cleaning instructions, improper installation, improper maintenance, failure to follow capacity charts, improperly wired electrical connections. The Warranty does not apply to abuse, willful or accidental damage, or to products used for other than their intended purpose. Normal wear parts such as Accessories, Attachments, or Electrical Components such as Fuses, Bulbs, Elements, and Switches carry a 90-Day Warranty only.

Bench Warranty (Machines Weighing 100 lb. or less)

Once the machine is Approved for Warranty Service, if the machine requires Warranty work in less than 30 days of purchase date, BakeMax will pay all shipping charges. Once the machine is received and repaired it will be returned to the user at BakeMax expense. Freight Damages during return shipping is the responsibility of the owner of the machine.

The following is not covered under the BakeMax Warranty:

1. Overtime Labor Rates are not covered by BakeMax.
2. All parts will be shipped via Ground Courier only; If Express Shipping is required, it will be the responsibility of the Customer or Dealer.
3. Travel for Warranty Service is covered up to 100 Miles /160 Km Roundtrip, any further mileage will be the responsibility of the Customer or Dealer.
4. There is no on-site Warranty Service for Residential Addresses or addresses outside of the contiguous United States (*Lower 48*) or Canada.

***BakeMax machines sold outside of the contiguous United States (Lower 48), or Canada will carry 1-Year Parts Warranty only.*

Terms & Conditions

Terms

Net 15 days subject to Credit Approval. All past due Accounts are subject to 2% per month Service Charge as per Credit Application. We accept Visa, MasterCard, and Discover Credit Cards. We also accept E-Transfer & Wire Transfer, additional fees may apply.

Pricing

All prices are subject to change without notice. All prices are Sales Tax Extra, should you be claiming Tax Exemption, Tax Exempt Forms must accompany your Purchase Order. BakeMax products are sold in Canadian and US Dollars. BakeMax is not responsible for specifications errors or printing errors.

Shipping

Free shipping to Canada and the U.S. Minimum order \$6,000 for BakeMax and \$10,000 for BakeMax America Cooking Line. Tailgate Delivery is \$90.00 minimum. All checks made Payable to Titan Ventures International Inc. BakeMax is not responsible for goods damaged during shipping. BakeMax is not responsible for any delays in delivery once product has left our Warehouse and is in the carrier's possession. Products shipped are to be inspected at time of delivery, the receiver is responsible for inspection. Damaged Freight Claims are to be claimed with the carrier. BakeMax assumes no responsibility for Damaged Freight. Shipping Insurance available by request. By signing your name on the delivery receipt without noting any damages, you are stating that you have received your shipment in Acceptable Condition.

Return Policy

Returns will not be Approved unless in Writing. Returns must be made within 30-Days of Purchase and must have a Return Authorization Number issued before returning. The purchase order number, reason for return, and the serial number(s) of the unit are required for the Return Authorization Number. Minimum return amount of \$100.00.

Returns are subject to a minimum restocking fee of 30%. The cost of any repairs or re-crating required will be charged back to the dealer. If there is a manufacturer's defect BakeMax® will pay standard freight returned and prepaid shipping back to the customer.

Special Order Items, Clearance / Discontinued Equipment, Parts, Refurbished/Demo Equipment, or Non-Standard items are not Returnable.

Ordering Information

Send purchase orders to BakeMax via e-mail orderdesk@bakemax.com or Fax (506-859-6929). Use Model or Part number when ordering including Voltage Requirements, and Product Description. Please include the Dealer, Name, Address, terms, special delivery, or instructions required or attention names to be applied to packaging. Please notify BakeMax should you need order confirmation or tracking numbers, by calling 1-800-565-2253 or email orderdesk@bakemax.com.

Special Terms and Conditions

BakeMax reserves the right to make improvements or equipment changes without prior permission. Setup and Installation are the end user's Responsibility. Failure to properly Install or Maintain Equipment may Void Warranty.

Catalog, Spec Sheets and Website

BakeMax is not liable for incorrect information found in our Catalog, Spec Sheets or Website. Please contact us to confirm specifications. Pictures and specifications are for general purposes only. Product may not be exactly as shown. Prices and availability may change at any time without notice. Dimensions shown may change at any time without notice.