

**BakeMax BMPLS7FE020
50 lbs. Freestanding
Electric Fryer
Operations Manual**



**Questions? OEM Parts?
Toll Free: 1-800-565-2253
Email: Service@BakeMax.com
www.BakeMax.com**



Warning & Safety

PLEASE READ AND FOLLOW INSTRUCTIONS BELOW TO PREVENT INJURY OR DAMAGE TO THE PRODUCT

BakeMax[®] (a registered trademark of Titan Ventures International Inc or TVI) is not responsible for any harm or injury caused due to any person's improper or negligent use of this equipment. The product shall only be operated by someone over the age of 18, of sound mind, and not under the influence of any drugs or alcohol, who has been trained in the correct operation of this machine, and is wearing authorized, proper safety clothing. This machine is intended for commercial use only. Any modification or miss use to the machine voids any warranty and may cause harm to individuals using the machine or around the machine while in operation.

- When using the machine, please ensure that you have read all the instructions within this manual.
- Be aware of your surroundings when using this machine, ensure there are no children or any other persons who are near the machine before operating.
- Do not put hand near moving parts.
- Remove all obstacles, which may interfere with machine functions.
- Keep work area clean and clear of clutter.
- Do not sit or stand on machine.
- Do not wear loose clothing or jewelry when operating machine as it may get caught in moving parts and cause injury.
- Stop using the machine and have it checked by an authorized service personal if it is not working properly.
- Disconnect from power source before performing and maintenance or cleaning on the machine.
- When the machine is not in use, please clean and store properly,
- Do not place any electrical parts or plug / cord in water or liquid.
- If the supply cord is damaged it must be replaced by an authorized service agent to avoid any electrical hazards.
- Keep power cord away from heat.
- Always ensure to follow local laws when operating your machine.

GENERAL INFORMATION

Before installing the appliance, read operation and maintenance instructions carefully. Wrong installation and part changing may damage the product or may cause injury to people. These are not our company's responsibility to damage the appliance intentionally, negligence, detriment because of disobeying instructions and regulations, wrong connections. Unauthorized intervention to appliance invalidates the warranty.

1. This instruction manual should be kept in a safe place for future reference.
2. Installation should be made in accordance with ordinances and security rules of that country by a qualified service personnel.
3. This appliance must be used by a trained person.
4. Please turn off the appliance immediately in the event of malfunction or failure. The appliance should be repaired only by authorized service personnel. Please demand original spare part.

WARNING:

- This device must be installed in accordance with applicable legislation and should only be used in a well-ventilated area. Please refer to the instructions before installing and using this device.
- Improper installation, adjustment, modification, service or maintenance can result in property damage, injury or death. Read the installation, use and maintenance instructions before installing or servicing this equipment.

FOR YOUR SAFETY: Do not use or store gasoline or other flammable gas or liquid in the device.

SAFETY SYMBOLS



These symbols are intended to alert the user to the presence of important operating and maintenance instructions in the manual accompanying the appliance.

SERVICE AND MAINTENANCE / MAINTENANCE AND REPAIRS

Contact your local authorized service agent for service or required maintenance.

Please record the model number, serial number, voltage and purchase date in the area below and have it ready when you call to ensure a faster service.

Model No.	BMPLS7FE020
Serial No.	
Voltage	
Purchase Date	

Authorized Service Agent Listing Reference the listing provided with the unit or for an updated listing go to:

Website: www.BakeMax.com

E-mail: Service@BakeMax.com

Service Help Desk	
Company	BakeMax
Website	www.BakeMax.com
Phone	(800) 565-2253
Fax	(506) 859-6929
Address	20 Caribou St, Moncton, NB E1H 0P3

IMPORTANT

Make sure that all paper protection and packaging have been removed before operating the device. This device should only be installed in the closed position.



WARNING :The device must be used by trained personnel.

PRODUCT DESCRIPTION

*The Professional Electric Fryers ,that provides high efficiency has been designed to be used in industrial kitchens.

Model	Electrical	Width	Depth	Height	Product Weight	Crated Weight
BMPLS7FE020	208V / 72.5A 15000W / 60Hz 1Ph	394mm 15.5"	870mm 34"	1004mm 39.5"	43 kg 95lbs.	53 kg 117lbs.
	208V / 42A 15000W / 60Hz 3Ph					

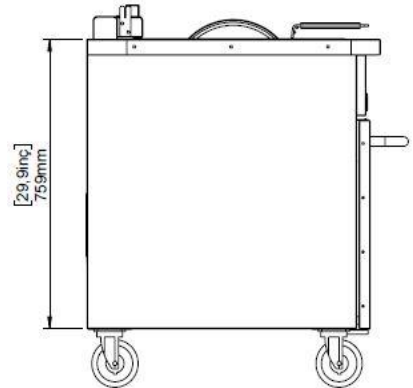
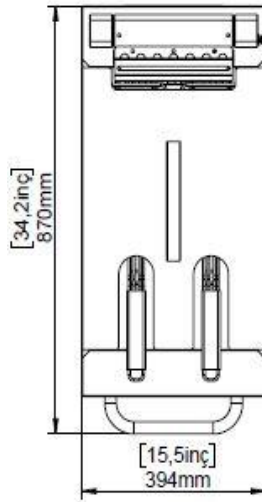
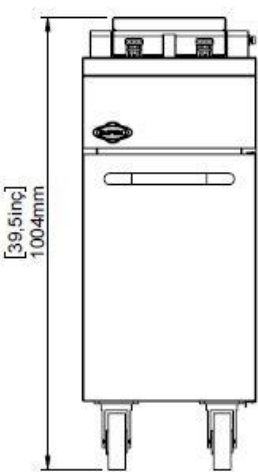

TRANSPORTATION

*This appliance can be moved by hand from area to area. Do not crash and drop the appliance while transporting.

UNPACKING

*Please unpack the package according to the security codes and ordinances of current country and get rid from the pack. Parts which contact with food are produced by stainless steel. All plastic parts are marked by material's symbol.

*Please check that all the parts of appliance had come completely and if they are damaged or not during the shipping.

INSTALLATION

*Please place the product to straight and sturdy ground, please take necessary steps against possibility of overturn.

*Technician who will serve in installation and service for the appliance must be professional in this subject and must have installation and service licenses from the company.

*Connection to Electric Power Supply must be made by an authorized person.

*Please be sure that the voltage connected to appliance must be equal with the voltage which is on appliance's label.













This appliance must be connected to an earthed outlet in accordance with safety rules and standards.

*Appliance's earthing must be connected to earthing line on panel which is nearest to electric installation.

*Connection to the main fuse and leak current fuse must be made in accordance with the current regulations.

*If the location where electric fryers are placed is covered with nonflammable heat insulation material, the distance between them must be 5 cm. Otherwise it should be at least 20 cm. The appliance shouldn't be operated under chimney hood.

SAFETY INSTRUCTIONS

-  *Do not use the appliance in insufficient lighted place.
-  *Do not touch the moving attachments while the appliance operates.
-  *Do not install the appliance in the presence of flammable or explosive materials.
-  *Do not operate the appliance when the machine is empty.
-  *Do not load so less or more than appliance's capacity.
-  *Do not attempt to use the appliance without suitable protective equipment.
-  *Because of any reason if there is a fire or flame flare where the appliance is used, turn off all gas valves and electric contactor switch quickly and use fire extinguisher. Never use water to extinguish the fire.
-  *All the damages because of not having earthing connection will not be on warranty.
-  *Level of oil mustn't be less than minimum level. Otherwise, it can be ignited.
-  *Level of oil mustn't be more than maximum level. Otherwise, the oil that overflows from fryer may cause combustion.
-  *Do not put the unstrained and frozen foods into the hot oil.

OPERATION

*Control Panel.

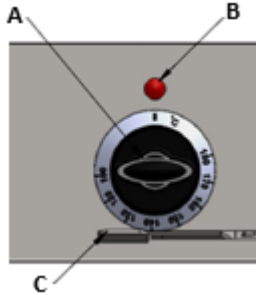

A : Heat setting button

B : Indicator lamp

C : Sliding attachment

* Operating.

- Before operating the fryer, place filter and filter into the tank.
- Turn the sliding ratchet that is on the oil evacuation pipet on the left and turn off the drainage taps.
- Open the lid and put oil in the tank. Pay attention to both minimum and maximum lines while adding oil into the tank.
- Plug in the appliance.
- Set the thermostat switch to desired heat to operate the appliance.
- Fryers are 2 type: single-tank, double-tank. There are 2 resistances and thermostats in every tank. If the thermostat switch is set to on position, the heaters start to work and indicator lamp that is on thermostat signals.
- When the oil temperature reaches indicator temperature, heaters are disabled through the agency of limit thermostat. When the oil temperature is lower than indicator temperature, the limit thermostat steps in, and heaters start to work.
- Put the materials that will be fried into the tank in the basket during oil heating.
- After putting the materials into the tank close the lid and start to fry.
- Add oil when the oil is at minimum level.
- After frying process, switch the thermostat to (0) position and unplug the appliance.
- Open the lid and take off the basket from tank.
- To remove the oil from fryer, first leave the oil to cool. Then attach the oil drainage pipe to the oil drainage hole.
- Slide the sliding sled to the right to remove the oil.

CLEANING & MAINTENANCE

➤ CLEANING AND MAINTENANCE AFTER EVERY USE

- Always turn off the appliance and disconnect from the power supply before cleaning.
- Clean the outer surface of the appliance with a wet cloth and chrome shiner.
- Do not use abrasive cleaning chemicals as these can leave harmful residues.
- Do not clean the appliance by spraying water directly, otherwise electric motor may get damaged.
- While cleaning the inside of the fryer, lift the heater handle, unsettle the heaters that are in the tank and take them to vertical position. Take off the baskets and filter that are in the tank.

➤ PERIODIC CLEANING AND MAINTENANCE

- Maintenance should be done by a qualified person.
- Get the periodic maintenance of the appliance once every 15 days.
- Clean the oil tank periodic times. Fill the tank with water and heat. This process will help to remove frozen and stucked oil.
- Maintenance of the appliance's contactor should be done by compressed air according to frequency of use.

CLEANING & MAINTENANCE

THE APPLIANCE DOESN'T OPERATE

1. Check if the appliance is plugged in.
2. Check the electrical connections and voltage.
3. Check the resistances.

THE APPLIANCE DOESN'T FRY WELL

1. Check the level of oil.
2. Check the thermostat switch. If the oil cannot be heated as desired, contact with authorized service.

THE APPLIANCE STOPPED

1. If the oil temperature reaches 230°C while the appliance is operating, limit thermostat will stop the circuit. In this situation the appliance cannot be operated. Leave the oil to be cooled to operate again. Then take off the thermostat switch that is on front panel and press the red button with a thin tool

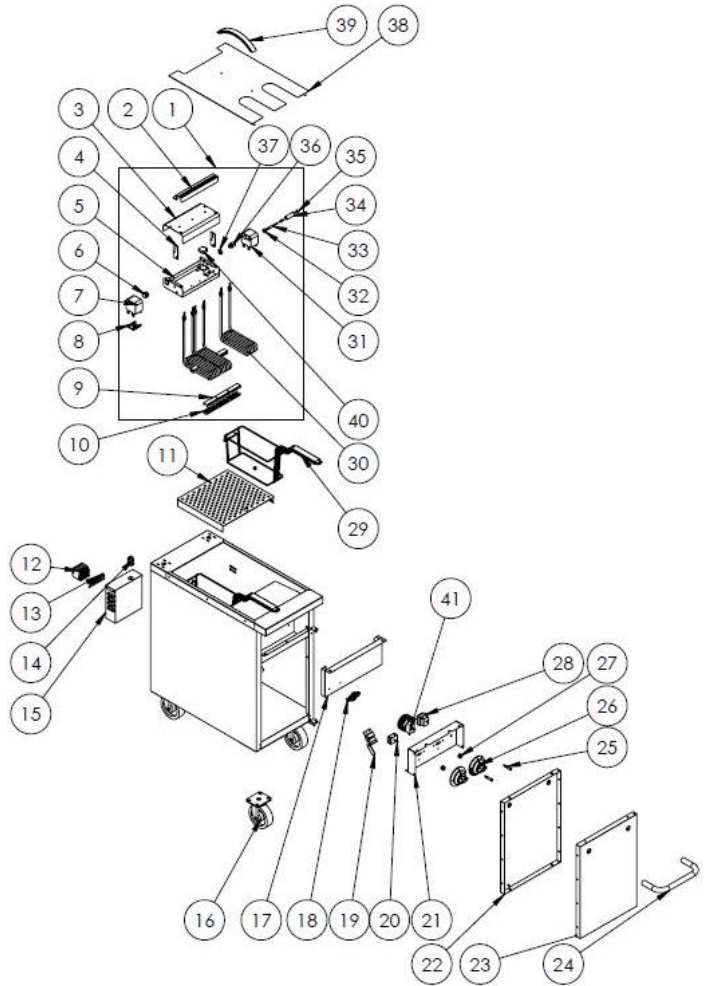

#	PART DESCRIPTION	FACTORY #
1	EMP.PLS.7FE020-USA RESISTOR ASSEMBLY	ARA-KNX.PG7-0054
2	EMP.PLS.7FE010-UL-BASKET HANGING SHEET	YSC-KNX.PG7-LZ-1246
3	EMP.PLS.7FE010-UL-RZS CONN MIDDLE TOP SC	YSC-KNX.PG7-PN-0958
4	EMP.PLS.7FE010-UL-CAP HOLDER SC	YSC-KNX.PG7-LZ-1247
5	EMP.PLS.7FE010-UL-RESISTANCE CONNECTION MIDDLE BOTTOM SHEET.	YSC-KNX.PG7-LZ-1244
6	2016-7FE010 HINGE BUSHING YELLOW	YTL-KNX.PG7-KS-0011

7	EMP.PLS.7FE010-UL-RESISTANCE CONNECTION LEFT SHEET	YSC-KNX.PG7-LZ-1242
8	EMP.7FE010 RESISTANCE RETAINING SHEET	YSC-KNX.PG7-LZ-0917
9	7FE010-2016 HEATER SUPPORT SHEET TOP	YSC-KNX.PG7-LZ-0638
10	7FE010-2016 HEATER SUPPORT SHEET BOTTOM	YSC-KNX.PG7-LZ-0637
11	EMP.PLS.7FE010-UL-BASKET BOTTOM SHEET	YSC-KNX.PG7-LZ-1239
12	AVK 10x10 MM RAIL CLAMP (BLUE)	M.ELK-KLM-038
13	VENDING MACHINE RAIL (10CM)	YEL-ERS.PR-KS-0001
14	PG-13.5 GRAY CABLE GLAND WITH NUT	M.ELK-RKR-PLS-007
15	EMP.PLS.7FE010-UL-TRAFO SC	YSC-KNX.PG7-PN-0939
16	125-37.5 POLYAMIDE CASTER WITH BRAKE TABLE	M.AKS-TKR-PSF-008
17	EMP.PLS.7FE010-UL-SUB PANEL SC EK	YSC-KNX.PG7-LZ-1236
18	EMPERO EMBOSSED METAL LABEL (PLUS)	M.AKS-OZL-MTL-006
19	1 FULL BORE BALL LEVER VALVE PN 10	M.MEK-TES-KVN-006
20	EGO SWITCH 0-1 SINGLE PHASE 49.22015.000 EGO	M.ELK-SLT-EGO-001
21	EMP.PLS.7FE010-UL-ELECTRICAL CONNECTION SC	YSC-KNX.PG7-LZ-1251
22	EMP.PLS.7FE010-UL-COVER INNER SHEET	YSC-KNX.PG7-PN-0954
23	EMP.PLS.7FE010-UL-COVER TOOTH SHEET	YSC-KNX.PG7-PN-0953
24	EMP.PLS.7FE010-UL-COVER HANDLE PIPE	YBR-KNX.PG7-KS-0021
25	C0275LFRL INDICATOR 10 MM 110-250V RED / UL RED LET SIGNAL LMB	M.ELK-LMB-SNY-012
26	EMP BUTTON ARROW BLACK PRINTED	M.AKS-DGM-EMP-024
27	FAUCET BUTTON SOCKET 6 MM ELK Ü.	M.AKS-DGM-SKT-002
28	5610549500 230C LIMITER L-750MM OLD (55.13544.010 -238 DEGREE EGO LIMITER)	M.ELK-MEK-LMT-015
29	EMP.PLS.7FE010-UL-FRYER BASKET 30X13X15 CM	M.AKS-SPT-INX-043
30	SET TOP 7FE20-UL 208V 5083W RESISTANCE	M.ELK-RZS-BRU-MKR-010
31	EMP.PLS.7FE010-UL-RESISTANCE CONNECTION RIGHT SHEET	YSC-KNX.PG7-LZ-1243
32	2016-7FE010 HINGE LOCK CONNECTION	YTL-KNX.PG7-KS-0008
33	2016-7FE010 HINGE LOCK INTERIOR	YTL-KNX.PG7-KS-0007
34	2016-7FE010 HINGE LOCK EXTERNAL	YTL-KNX.PG7-KS-0006
35	2016-7FE010 HINGE HANDLE NEW	YTL-KNX.PG7-KS-0009
36	2016-7FE010 HINGE BUSHING CHROME	YTL-KNX.PG7-KS-0010
37	82 MM WATER PASSAGE NUTQ	YTL-KNX.KFR-KS-0013
38	EMP.PLS.7FE010-UL-TOP COVER SHEET	YSC-KNX.PG7-LZ-1241

39	GÜRSAN BRONZE ANODIZED HANDLE LONG 243MM HOLE OTHERWISE 210MM	M.AKS-KLP-LUX-003
40	2016-7FG010 HINGE SPRING	M.YAY-PG-004
41	55.13032.140 100-180 DEGREE EGO THERMOSTAT	M.ELK-MEK-TRM1-022

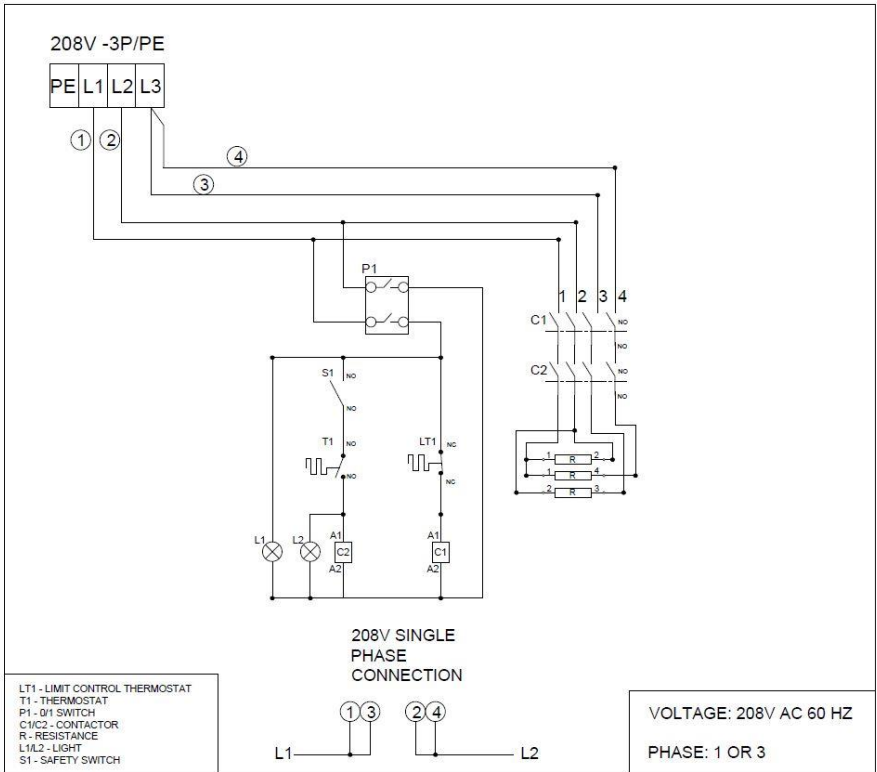

Warranty & Service

BakeMax provides a 1-Year Limited Parts and Labor warranty on most items, there are select items which carry a Limited 2-Year Warranty. Extended Warranty is available on some products. Please contact us for details. The Warranty is not transferable and is limited to original installation of equipment sold by BakeMax for the original user.

For all Warranty Claims, Proof of Purchase and/or Serial Number is required. Once the machine is approved, BakeMax will provide our customers with on-site Warranty Coverage on all equipment more than 100lbs. BakeMax assumes no responsibility for down time or loss of product. Repairs must be Pre-Authorized by BakeMax and have a Service Authorization Number issued prior to commencing Warranty Service.

Warranty begins 10-Days after shipping from warehouse; delays in installation which would extend the Warranty must be Approved. All equipment must be installed and connected by Qualified Professionals in accordance with the Manual Specification. Products shipped are to be inspected at time of delivery, the receiver is responsible for inspection.

Any abuse or improper use of the equipment will void the warranty. This includes failure to follow all cleaning instructions, improper installation, improper maintenance, failure to follow capacity charts, improperly wired electrical connections. The Warranty does not apply to abuse, willful or accidental damage, or to products used for other than their intended purpose. Normal wear parts such as Accessories, Attachments, or Electrical Components such as Fuses, Bulbs, Elements, and Switches carry a 90-Day Warranty only.

Bench Warranty (Machines Weighing 100 lb. or less)

Once the machine is Approved for Warranty Service, if the machine requires Warranty work in less than 30 days of purchase date, BakeMax will pay all shipping charges. Once the machine is received and repaired it will be returned to the user at BakeMax expense. Freight Damages during return shipping is the responsibility of the owner of the machine.

The following is not covered under the BakeMax Warranty:

1. Overtime Labor Rates are not covered by BakeMax.
2. All parts will be shipped via Ground Courier only; If Express Shipping is required, it will be the responsibility of the Customer or Dealer.
3. Travel for Warranty Service is covered up to 100 Miles /160 Km Roundtrip, any further milage will be the responsibility of the Customer or Dealer.
4. There is no on-site Warranty Service for Residential Addresses or addresses outside of the contiguous United States (*Lower 48*) or Canada.

***BakeMax machines sold outside of the contiguous United States (Lower 48), or Canada will carry 1-Year Parts Warranty only.*

Questions? OEM Parts?

Toll Free: 1-800-565-2253

Email: Info@BakeMax.com

www.BakeMax.com

BakeMax[®]

www.BakeMax.com