

BakeMax BMPLS7IE030

36" Countertop

Electric Griddle



Questions? OEM Parts?

Toll Free: 1-800-565-2253

Email: Service@BakeMax.com

www.BakeMax.com



Warning & Safety

PLEASE READ AND FOLLOW INSTRUCTIONS BELOW TO PREVENT INJURY OR DAMAGE TO THE PRODUCT

BakeMax® (a registered trademark of Titan Ventures International Inc or TVI) is not responsible for any harm or injury caused due to any person's improper or negligent use of this equipment. The product shall only be operated by someone over the age of 18, of sound mind, and not under the influence of any drugs or alcohol, who has been trained in the correct operation of this machine, and is wearing authorized, proper safety clothing. This machine is intended for commercial use only. Any modification or miss use to the machine voids any warranty and may cause harm to individuals using the machine or around the machine while in operation.

- When using the machine, please ensure that you have read all the instructions within this manual.
- Be aware of your surroundings when using this machine, ensure there are no children or any other persons who are near the machine before operating.
- Do not put hand near moving parts.
- Remove all obstacles, which may interfere with machine functions.
- Keep work area clean and clear of clutter.
- Do not sit or stand on machine.
- Do not wear loose clothing or jewelry when operating machine as it may get caught in moving parts and cause injury.
- Stop using the machine and have it checked by an authorized service personal if it is not working properly.
- Disconnect from power source before performing and maintenance or cleaning on the machine.
- When the machine is not in use, please clean and store properly,
- Do not place any electrical parts or plug / cord in water or liquid.
- If the supply cord is damaged it must be replaced by an authorized service agent to avoid any electrical hazards.
- Keep power cord away from heat.
- Always ensure to follow local laws when operating your machine.

GENERAL INFORMATION

Before installing the appliance, read operation and maintenance instructions carefully. Wrong installation and part changing may damage the product or may cause injury on people. These are not in our company's responsibility to damage the appliance intentionally, negligence, detriments because of disobeying instructions and regulations, wrong connections, un-authorized intervention to appliance invalidates the warranty.

1. This instruction manual should be kept in a safe place for future reference.
2. **Installation should be made in accordance with ordinances and security rules of that country by qualified service personnel.**
3. This appliance must be used by a trained person.
4. Please turn off the appliance immediately in the event of malfunction or failure. The appliance should be repaired only by authorized service personnel. Please demand original spare part.

WARNING:
<ul style="list-style-type: none">• This device must be installed in accordance with applicable legislation and should only be used in a well-ventilated area. Please refer to the instructions before installing and using this device.• Improper installation, adjustment, modification, service or maintenance can result in property damage, injury or death. Read the installation, use and maintenance instructions before installing or servicing this equipment.

SAFETY SYMBOLS



These symbols are intended to alert the user to the presence of important operating and maintenance instructions in the manual accompanying the appliance.

SERVICE AND MAINTENANCE / MAINTENANCE AND REPAIRS

Contact your local authorized service agent for service or required maintenance.

Please record the model number, serial number, voltage and purchase date in the area below and have it ready when you call to ensure a faster service.

Model No.	BMPLS7IE030
Serial No.	
Voltage	
Purchase Date	

Authorized Service Agent Listing Reference the listing provided with the unit or for an updated listing go to:

Website: www.BakeMax.com

E-mail: Service@BakeMax.com

Service Help Desk	
Company	BakeMax
Website	www.BakeMax.com
Phone	(800) 565-2253
Fax	(506) 859-6929
Address	20 Caribou St, Moncton, NB E1H 0P3

IMPORTANT

Make sure that all paper protection and packaging have been removed before operating the device. This device should only be installed in the closed position.



WARNING :The device must be used by trained personnel.

PRODUCT DESCRIPTION

*The Professional Electric Griddle, that provides high efficiency has been designed to be used in industrial kitchens.

Model #	Electrical	Width	Depth	Height	Product Weight	Crated Weight
BMPLS7IE030	208V / 58A / 12000W / 1Ph 208V / 33.5A / 12000W / 3Ph	914.4mm 36.00"	879mm 34.6"	438mm 17.24"	122.5kg 270lbs.	140kg 309lbs.

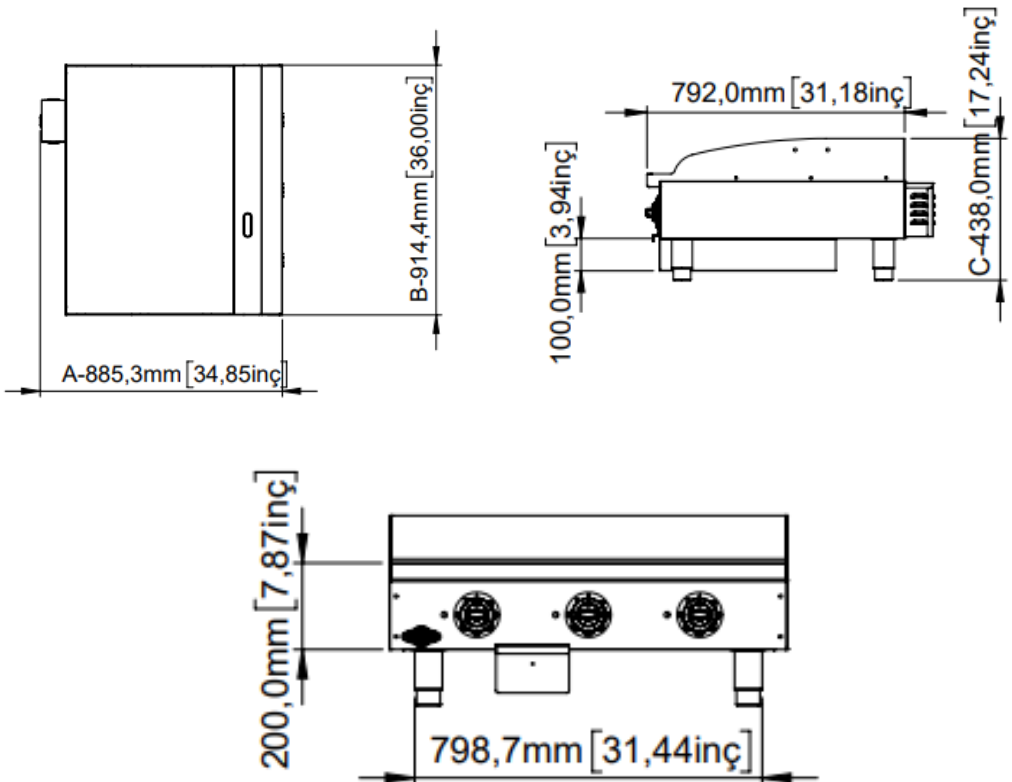

TRANSPORTATION

*This appliance can not be moved by hand from area to area. It must be moved on pallet with forklift truck.

UNPACKING

*Please unpack the package according to the security codes and ordinances of current country and get rid from the pack. Parts which contacts with food are produced by stainless steel. All plastic parts are marked by material's symbol.

*Please check that all the parts of appliance had come completely and if they are damaged or not during the shipping.

INSTALLATION

*Please place the product to straight and sturdy ground, please take necessary steps against possibility of overturn.

*Technician who will serve for installation and service for the appliance must be professional on this subject and must have installation and service licenses by the company.

*Connection to Electric Power Supply must be done by authorized person.

*Please be sure that the voltage connected to appliance must be equal with the voltage which is on appliance's label.









 This appliance must be connected to an earthed outlet in accordance with safety rules and standards.

*Appliance's earthing must be connected to earthing line on panel which is nearest to electric installation.

*Connection to the main fuse and leak current fuse must be done in accordance with the current regulations.

*If the location where Electric Grills placed is covered with nonflammable heat insulation material, the distance between them must be 6". Otherwise it should be at least 6". The appliance must be operated under the flue hood.

SAFETY INSTRUCTIONS

-  *Do not use the appliance in insufficient lighted place.
-  *Do not touch the moving attachments while the appliance operates.
-  *Do not install the appliance in the presence of flammable or explosive materials.
-  *Do not operate the appliance when the machine is empty.
-  *Do not load so less or more than appliance's capacity.
-  *Do not attempt to use the appliance without suitable protective equipment.
-  *Because of any reason if there is a fire or flame flare where the appliance is used, turn off all gas valves and electric contactor switch quickly and use fire extinguisher. Never use water to extinguish the fire.
-  *All the damages because of not having earthing connection will not be on warranty.
-  *Do not put watery materials on the grill. Otherwise oil splashes may cause serious burn.

OPERATION

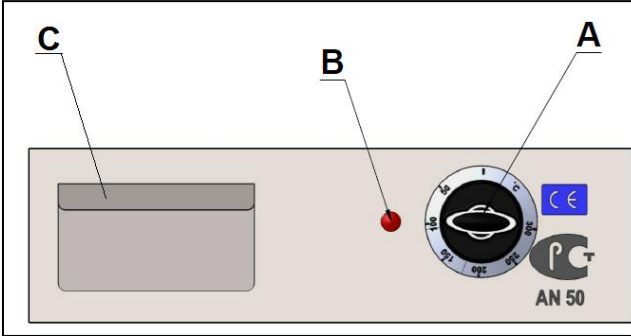

- A : Heat setting button
- B : Indicator lamp
- C : Oil drawer

*Operating Instructions

- Plug in the grill.
- To operate the grill, switch the knob to the (I) position.
- Operate the grill when it is empty for the first use. Then it will be ready for use.
- To set the appliance's temperature, switch the thermostat to desired temperature.
- When the thermostat switch is turned, the heaters start to operate, and indicator lamp on switch signals as it operates. During the operation of heaters, the thermostat steps in and signal lamp becomes off if the grill is off.
- Put the materials that will be cooked on the grill, while it is being heated.
- While the cooking is going on at grill be sure that the used oil is accumulated at oil drawer.
- After the operation is completed switch to (0) position.

INSTALLATION CLEARANCES

	COMBUSTIBLES	NONCOMBUSTIBLES
SIDES	6"	0
BACK	6"	0
LEFT	6"	0

CLEANING & MAINTENANCE

➤ CLEANING AND MAINTENANCE AFTER EVERY USE

- Always turn off the appliance and disconnect from the power supply before cleaning.
- Clean the outer surface of the appliance with a wet cloth and chrome shiner.
- Do not use abrasive cleaning chemicals as these can leave harmful residues.
- Do not clean the appliance by spraying water directly, otherwise electric motor may get damaged.
- Clean the grill with suitable scraper after every use.

➤ PERIODIC CLEANING AND MAINTENANCE

- Maintenance should be done by a qualified person.
- Get the periodic maintenance of the appliance once every 15 days.
- Clean the oil drawer periodic times. For this fill the oil drawer with water and heat it. This process will help to clean frozen and stuck oil.
- Maintenance of the appliance's contactor should be done by compressed air according to frequency of use.

Empty the grease drawer as needed throughout the day and regularly clean at least once daily.

Clean the griddle regularly. A clean griddle always looks better, lasts longer and performs better. To produce evenly cooked, perfectly browned griddle products keep the griddle plate clean and free of carbonized grease. Carbonized grease on the surface hinders the transfer of heat from the griddle surface to the food, resulting in spotty browning and loss of cooking efficiency. Carbonized grease tends to cling to griddle foods, giving them a highly unsatisfactory and unappetizing appearance. To keep the griddle clean and operating at peak efficiency, follow these procedures:

AFTER EACH USE

Clean the griddle with a griddle scraper during the work shift.

ONCE PER DAY

Thoroughly clean the griddle back splash, sides and front. Turn the griddle off and allow it to cool down between 275°F - 300°F, apply some water and clean it with a griddle scraper. Remove, empty and wash the grease drawer in the same manner as an ordinary cooking utensil.

ONCE PER WEEK

Clean the griddle surface thoroughly. A detergent safe for steel may be used on the plate surface to help clean it but be sure the detergent is thoroughly removed by flushing with clear water. After removal of detergent, the surface of the griddle plate should be seasoned according to the instructions in this manual. Clean stainless-steel surfaces with a damp cloth and polish with a soft dry cloth. To remove discoloration, use a griddle cleaner. If the griddle usage is very high, consider conducting this weekly cleaning procedure more than once a week.

1. Do not use a brick or griddle stone for cleaning.
2. Do not use a waterjet to clean the griddle.
3. Do not use chlorine sanitizer in contact with the griddle. Contact can cause discoloration, corrosion and permanent damage.
4. Do not use cleaning agents with Sodium Hydroxide in them, which is common in household oven cleaners.

SHUTDOWN OF GRIDDLE

Turn all thermostats to the OFF position. This will shut down the griddle completely.

EXTENDED SHUTDOWN

Shut off the main electrical supply. Apply a heavy coat of vegetable oil over the griddle plate to inhibit rust.

TROUBLESHOOTING

THE APPLIANCE DOESN'T OPERATE

1. Check if the appliance is plugged in.
2. Check the electrical connections and voltage.
3. Check the fuse if it is on or not.

THE APPLIANCE DOESN'T COOK WELL

1. Check if the appliance is operated at suitable temperature or not.

THE APPLIANCE STOPPED

1. The appliance can stop due to low voltage. In this situation check the voltage.

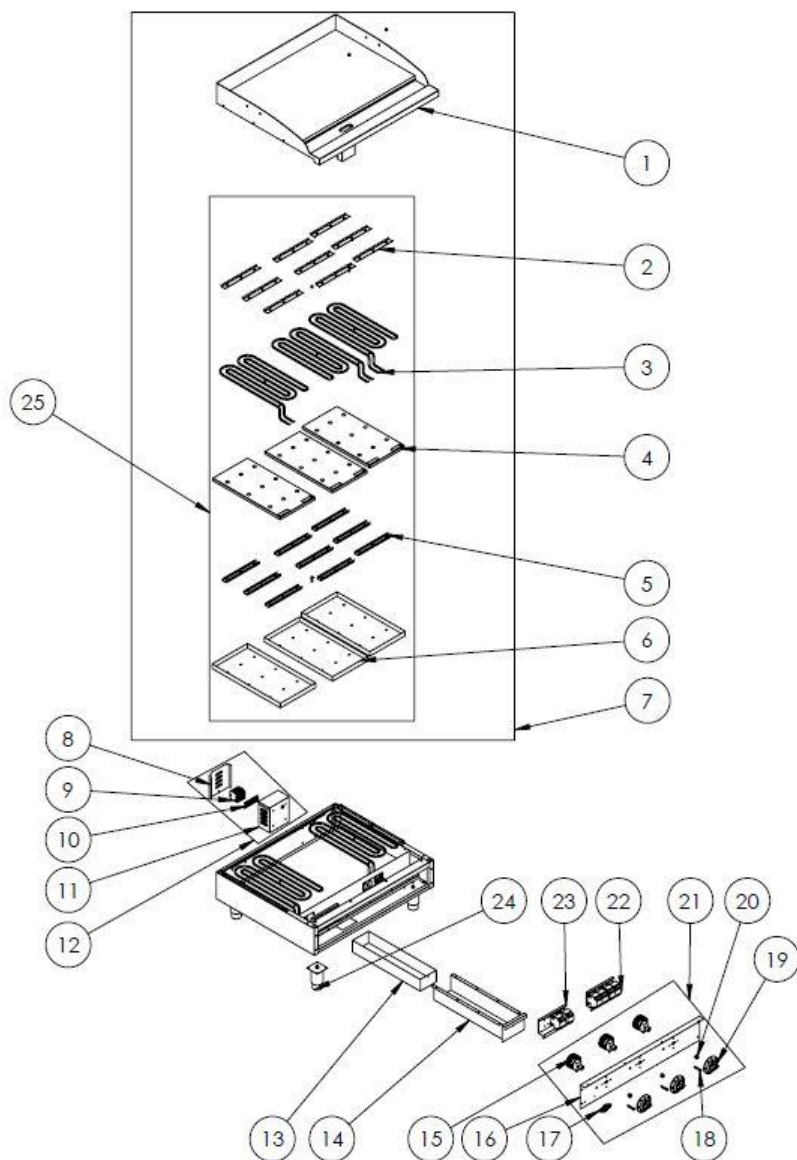

#	Part Description	Factory #
1	907.4x610x20 ST-37 FLAT EMP.PLS.7IE030-UL PLATINA	M.PLTN-PGP-700-014
2	EMP.PLS.7IE040-UL-RESISTANCE HOLDING SC	YSC-KNX.PG7-LZ-1266
3	EMP.PLS.7IE040-UL REZISTANSI 208V-4 kW	-
4	EMP.PLS.7IE040-UL-ISOLATION SUB SC	YSC-KNX.PG7-LZ-1265
5	EMP.PLS.7IE040-UL RESISTANCE SUPPORT SC	YSC-KNX.PG7-LZ-1368
6	EMP.PLS.7IE040-UL-INSULATION TOP SC	YSC-KNX.PG7-PN-0974
7	PLATINA MON.	EMP.PLS.7IE030-UL
8	EMP.PLS.7IE040-UL-TRAFO COVER SC	YSC-KNX.PG7-PN-0941
9	AWK-10x10 MM RAIL FLANGE (BLUE)	M.ELK-KLM-038
10	VENDING MACHINE RAIL (10CM)	YEL-ERS.PR-KS-0001
11	EMP.PLS.7IE040-UL-TRAFO SC	YSC-KNX.PG7-PN-0940
12	REAR PANEL MNTJ.	EMP.PLS.7IE040-UL
13	EMP.PLS.7IE040-UL-OIL DRAWER SC	YSC-KNX.PG7-PN-0971
14	EMP.PLS.7IE040-UL-OIL SLED SC	YSC-KNX.PG7-PN-0972
15	THERMOSTAT (MANUAL) K.50.P.1125.001	M.ELK-MEK-TRM1-009
16	EMP.PLS.7IE030-UL-FRONT PANEL	YSC-KNX.PG7-LZ-1555
17	EMPERO EMBOSSED METAL LABEL (PLUS)	M.AKS-OZL-MTL-006
18	INDICATOR LIGHTS 0568 - RED SIGNAL LAMP (DIAMETER 9,8MM)110V- USA	M.ELK-LMB-SNY-011
19	122-572 F BUTTON BLACK AND WHITE BUMPER	M.AKS-DGM-EMP-054
20	FAUCET BUTTON SOCKET 6 MM ELK Ü.	M.AKS-DGM-SKT-002
21	FRONT PANEL MNTJ	EMP.PLS.7IE030-UL
22	SCHNEIDER ELECTRIC CONTACTOR	LC1D09
23	EMP.PLS.7IE020-UL CONTACTOR SC	YSC-KNX.PG7-LZ-1427
24	13 CM CHROME PIPE FOOT ASSEMBLY-1	M.AKS-AYK-INX-001
25	RESISTANCE MON	EMP.PLS.7IE040-UL

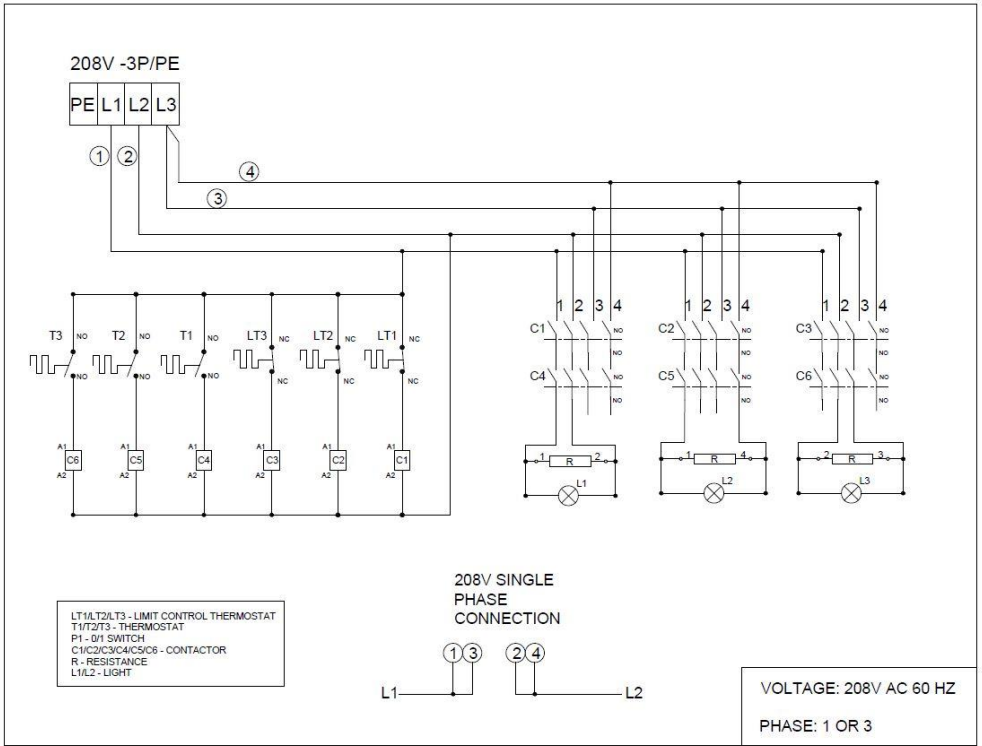

Warranty & Service

BakeMax provides a 1-Year Limited Parts and Labor warranty on most items, there are select items which carry a Limited 2-Year Warranty. Extended Warranty is available on some products. Please contact us for details. The Warranty is not transferable and is limited to original installation of equipment sold by BakeMax for the original user.

For all Warranty Claims, Proof of Purchase and/or Serial Number is required. Once the machine is approved, BakeMax will provide our customers with on-site Warranty Coverage on all equipment more than 100lbs. BakeMax assumes no responsibility for down time or loss of product. Repairs must be Pre-Authorized by BakeMax and have a Service Authorization Number issued prior to commencing Warranty Service.

Warranty begins 10-Days after shipping from warehouse; delays in installation which would extend the Warranty must be Approved. All equipment must be installed and connected by Qualified Professionals in accordance with the Manual Specification. Products shipped are to be inspected at time of delivery, the receiver is responsible for inspection.

Any abuse or improper use of the equipment will void the warranty. This includes failure to follow all cleaning instructions, improper installation, improper maintenance, failure to follow capacity charts, improperly wired electrical connections. The Warranty does not apply to abuse, willful or accidental damage, or to products used for other than their intended purpose. Normal wear parts such as Accessories, Attachments, or Electrical Components such as Fuses, Bulbs, Elements, and Switches carry a 90-Day Warranty only.

Bench Warranty (Machines Weighing 100 lb. or less)

Once the machine is Approved for Warranty Service, if the machine requires Warranty work in less than 30 days of purchase date, BakeMax will pay all shipping charges. Once the machine is received and repaired it will be returned to the user at BakeMax expense. Freight Damages during return shipping is the responsibility of the owner of the machine.

The following is not covered under the BakeMax Warranty:

1. Overtime Labor Rates are not covered by BakeMax.
2. All parts will be shipped via Ground Courier only; If Express Shipping is required, it will be the responsibility of the Customer or Dealer.
3. Travel for Warranty Service is covered up to 100 Miles /160 Km Roundtrip, any further milage will be the responsibility of the Customer or Dealer.
4. There is no on-site Warranty Service for Residential Addresses or addresses outside of the contiguous United States (*Lower 48*) or Canada.

***BakeMax machines sold outside of the contiguous United States (*Lower 48*), or Canada will carry 1-Year Parts Warranty only.*

Questions? OEM Parts?

Toll Free: 1-800-565-2253

Email: Info@BakeMax.com

www.BakeMax.com

BakeMax[®]

www.BakeMax.com