

BakeMax BMPLS7IND010

Countertop 2-Burner

Heavy-Duty Induction Cooker



Questions? OEM Parts?

Toll Free: 1-800-565-2253

Email: Service@BakeMax.com

www.BakeMax.com



Warning & Safety

PLEASE READ AND FOLLOW INSTRUCTIONS BELOW TO PREVENT INJURY OR DAMAGE TO THE PRODUCT

BakeMax® (a registered trademark of Titan Ventures International Inc or TVI) is not responsible for any harm or injury caused due to any person's improper or negligent use of this equipment. The product shall only be operated by someone over the age of 18, of sound mind, and not under the influence of any drugs or alcohol, who has been trained in the correct operation of this machine, and is wearing authorized, proper safety clothing. This machine is intended for commercial use only. Any modification or miss use to the machine voids any warranty and may cause harm to individuals using the machine or around the machine while in operation.

- When using the machine, please ensure that you have read all the instructions within this manual.
- Be aware of your surroundings when using this machine, ensure there are no children or any other persons who are near the machine before operating.
- Do not put hand near moving parts.
- Remove all obstacles, which may interfere with machine functions.
- Keep work area clean and clear of clutter.
- Do not sit or stand on machine.
- Do not wear loose clothing or jewelry when operating machine as it may get caught in moving parts and cause injury.
- Stop using the machine and have it checked by an authorized service personal if it is not working properly.
- Disconnect from power source before performing and maintenance or cleaning on the machine.
- When the machine is not in use, please clean and store properly,
- Do not place any electrical parts or plug / cord in water or liquid.
- If the supply cord is damaged it must be replaced by an authorized service agent to avoid any electrical hazards.
- Keep power cord away from heat.
- Always ensure to follow local laws when operating your machine.

GENERAL INFORMATION

Before installing the appliance, read operation and maintenance instructions carefully. Wrong installation and part changing may damage the product or may cause injury on people. These are not in our company's responsibility to damage the appliance intentionally, negligence, detriments because of disobeying instructions and regulations, wrong connections, un-authorized intervention to appliance invalidates the warranty.

1. This instruction manual should be kept in a safe place for future reference.
2. **Installation should be made in accordance with ordinances and security rules of that country by qualified service personnel.**
3. This appliance must be used by a trained person.
4. Please turn off the appliance immediately in the event of malfunction or failure. The appliance should be repaired only by authorized service personnel. Please demand original spare part.

WARNING:

- This device must be installed in accordance with applicable legislation and should only be used in a well-ventilated area. Please refer to the instructions before installing and using this device.
- Improper installation, adjustment, modification, service or maintenance can result in property damage, injury or death. Read the installation, use and maintenance instructions before installing or servicing this equipment.

SAFETY SYMBOLS



These symbols are intended to alert the user to the presence of important operating and maintenance instructions in the manual accompanying the appliance.

SERVICE AND MAINTENANCE / MAINTENANCE AND REPAIRS

Contact your local authorized service agent for service or required maintenance.

Please record the model number, serial number, voltage and purchase date in the area below and have it ready when you call to ensure a faster service.

Model No.	BMPLS7IND010
Serial No.	
Voltage	
Purchase Date	

Authorized Service Agent Listing Reference the listing provided with the unit or for an updated listing go to:

Website: www.BakeMax.com

E-mail: Service@BakeMax.com

Service Help Desk	
Company	BakeMax
Website	www.BakeMax.com
Phone	(800) 565-2253
Fax	(506) 859-6929
Address	20 Caribou St, Moncton, NB E1H 0P3

IMPORTANT

Make sure that all paper protection and packaging have been removed before operating the device. This device should only be installed in the closed position.



WARNING :The device must be used by trained personnel.

PRODUCT DESCRIPTION

*The Professional Electric Induction Cookers ,that provides high efficiency has been designed to be used in industrial kitchens.

Model #	Electrical	Width	Depth	Height	Product Weight	Crated Weight
BMPLS7IND010	208V / 30A / 6000W / 1Ph	375mm 14.7"	885mm 34.8"	329mm 12.95"	26kg 57lbs.	43kg 95lbs.

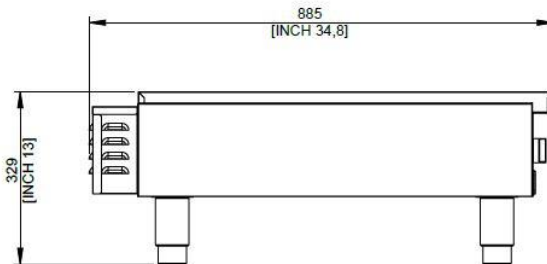
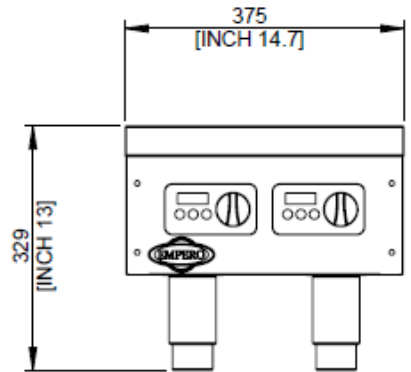
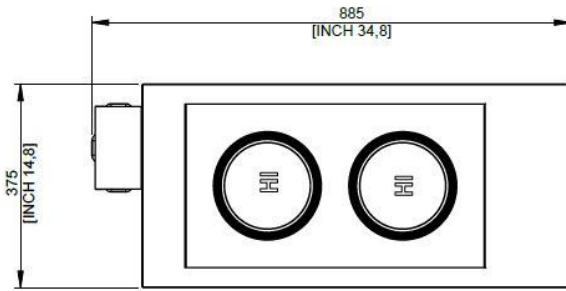

TRANSPORTATION

*This appliance can not be moved by hand from area to area. It must be moved on pallet with forklift truck.

UNPACKING

*Please unpack the package according to the security codes and ordinances of current country and get rid from the pack. Parts which contacts with food are produced by stainless steel. All plastic parts are marked by material's symbol.

*Please check that all the parts of appliance had come completely and if they are damaged or not during the shipping.

INSTALLATION

*Please place the product to straight and sturdy ground, please take necessary steps against possibility of overturn.

*Technician who will serve for installation and service for the appliance must be professional on this subject and must have installation and service licenses by the company.

*Connection to Electric Power Supply must be done by authorized person.

*Please be sure that the voltage connected to appliance must be equal with the voltage which is on appliance's label.



This appliance must be connected to an earthed outlet in accordance with safety rules and standards.

*Appliance's earthing must be connected to earthing line on panel which is nearest to electric installation.

*Connection to the main fuse and leak current fuse must be done in accordance with the current regulations.

*If the location where Electric Grills placed is covered with nonflammable heat insulation material, the distance between them must be 6". Otherwise it should be at least 6". The appliance must be operated under the flue hood.

WARNINGS

 **DANGER** Risk of fire/shock/equipment failure. All minimum clearances must be maintained. Do not obstruct vents or openings.

 **Warning** This equipment is intended for indoor use only. Do not install or operate this equipment in outdoor areas.

NOTICE: The reliability of the appliance can only be guaranteed when it is used properly. The appliance must always be operated within the limits and/or the operating conditions provided in this manual.

NOTICE: Avoid dropping any hard objects onto the equipment. Damages to the heating surface will shorten the life cycle of the equipment and incur high service costs.

NOTICE: Induction appliances are more powerful, heat up quicker, and cook food faster than conventional cooking equipment. Your induction appliance will require different use and care than other conventional equipment.

Do not operate the equipment without reading this manual and understanding all safety requirements.

 **DANGER** If any part of the appliance is cracked or broken, turn Off directly the appliance and Immediately disconnect the appliance from the supply. Do not touch any parts inside the appliance.

Disconnect electric power at the main power disconnect for all equipment being serviced.

Failure to disconnect the power at the main power supply disconnect could result in serious injury or death. The power switch DOES NOT disconnect incoming power. Contact an authorized service agency for assistance.

 **DANGER** Do not operate any appliance with a damaged or pinched cord or a damaged plug. All repairs must be performed by a qualified service company.

 **DANGER** Keep power cord AWAY from HEATED surfaces. DO NOT immerse power cord or plug in water. DO NOT let power cord hang over edge of table or counter.

 **DANGER** Never stand, sit, or lean on the equipment! They are not designed to hold the weight of an adult, and may collapse or tip if misused in this manner.

 **Warning** Risk of burns from high temperatures. You may get burnt if you touch any of the parts during operation. Surfaces close to the cooking area including side panels may get hot enough to burn skin. Use extreme caution to avoid coming in contact with hot surfaces or hot grease. Wear personal protective equipment.

 **Warning** During operation, it is possible that the floor around the unit become slippery. Wear suitable footwear and clean the floor if necessary.

 **Caution! Short Cook Time** Induction appliances cook food faster than conventional cooking equipment. To avoid overheating and burning, check the cooking process frequently. Never leave the appliance unattended during operation.

 **Caution!** Metallic objects are heated up very quickly when placed on the induction cook zone during operation. To avoid injury, DO NOT place any objects such as closed cans, aluminum objects (aluminum foils), cutlery, jewelry, or watches on the appliance. DO NOT place any object such as paper, cardboard, or cloth on the cooking surface, because this creates a fire hazard. DO NOT place credit cards, phone cards, tapes, or any objects that are sensitive to magnetism on the appliance. DO NOT use the appliance for storage. DO NOT place any paper products, cooking utensils, cutlery, plastic vessels or food on the appliance.

NOTICE: Do not use the cooktop for food preparation such as cutting and chopping.

SAFETY INSTRUCTIONS



*Do not use the appliance in insufficient lighted place.



*Do not touch the moving attachments while the appliance operates.



*Do not install the appliance in the presence of flammable or explosive materials.



*Do not operate the appliance when the machine is empty.



*Do not load so less or more than appliance's capacity.



*Do not attempt to use the appliance without suitable protective equipments.



*Because of any reason if there is a fire or flame flare where the appliance is used, turn off all gas valves and electric contactor switch quickly and use fire extinguisher. Never use water to extinguish the fire.



*All the damages because of not having earthing connection will not be on warranty.



*Do not spray controls or outside of unit with liquids or cleaning agents.



*Unplug when not in use.



* Do not place any objects inside the air intake or exhaust panels.



FUNCTION AND PURPOSE

This unit is intended to be used with induction-ready cookware (see below) with a flat, ferrous base measuring 4-1/2" (11.4 cm) to 10-1/4" (26 cm) wide. This unit is intended for use in commercial foodservice operations only. It is not intended for household, industrial or laboratory use.

Induction Ready Cookware

- Ferrous stainless steel
- Iron
- Cast iron

Unsuitable Cookware



NOTICE: Equipment Damage Hazard

Not intended for use with aluminum pans with a metal disk on the bottom. Under high heat, the metal disk will separate from the pan. These pans may damage your unit and void your warranty.

- Cookware with a base less than 4-1/2" (11.4 cm)
- Pottery, glass, aluminum, bronze or copper cookware
- Cookware with any type of footed base

OPERATION

SELECTING TEMPERATURE

1. Turn knob until the desired temperature is shown on the display.
2. Leave the knob for approximate 5 seconds, the display will show alternately the actual detected temperature and set temperature.

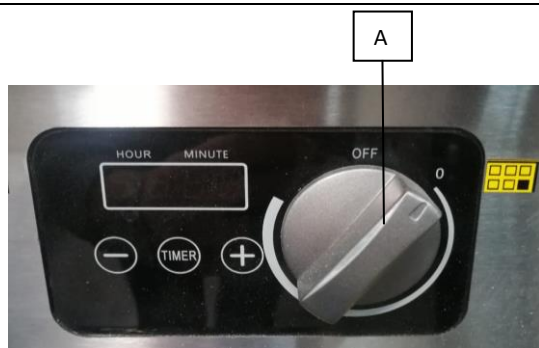

- A** : ADJUSTMENT KNOB
B : TIME SETTING
C : TIME REDUCTION
BUTTON
D : TIME INCREASE BUTTON

*Operating;

- Turn the cooktop (ON) by depress (ON/OFF) button
- Place cookware containing ingredients on the cooktop.
- Depress the Temperature Mode buton.
- Depress the (+) or (-) buttons and set until the desired cooking temperature appears on the LED display. The temperature displayed will change from the set temperature to the measured temperature. LED will Show (1-10) :
60°C, 80°C, 100°C, (initial value). 120°C, 140°C, 160°C, 180°C, 200°C, 220°C, 240°

CLEANING & MAINTENANCE

➤ CLEANING AND MAINTENANCE AFTER EVERY USE

- Always turn off the appliance and disconnect from the power supply before cleaning.
- Clean the outer surface of the appliance with a wet cloth and chrome shiner.
- Do not use abrasive cleaning chemicals as these can leave harmful residues.
- Do not clean the appliance by spraying water directly, otherwise electric motor may get damaged.
- Unplug the unit and let it completely cool.
- Wipe the unit exterior with a clean damp cloth.

NOTICE: Do not use abrasive materials, scratching cleansers or a souring pad to clean the unit. These can damage the finish.

- Thoroughly wipe off any mild soap or chemical cleaners.

NOTICE: Residue could corrode the surface of the unit.

➤ PERIODIC CLEANING AND MAINTENANCE

- Maintenance should be done by qualified person.
- Get the periodic maintenance of the appliance once in every 15 days.
- Check the heater's electric connection in periodic times.

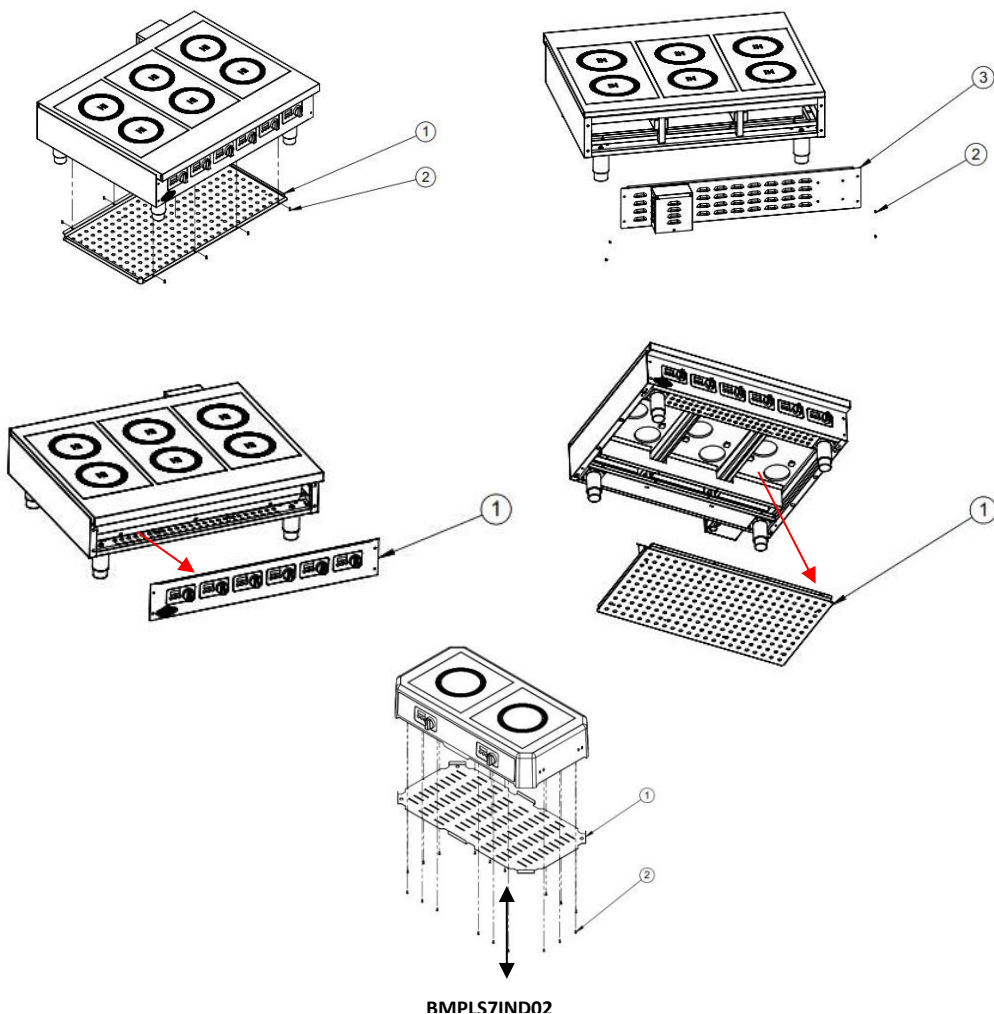

- We recommend cleaning the bottom panel and front panel (No 1) and back panel (No 3) at least every year. Please remove and remove the screws (No 2) with screwdriver, clean with wet cloth. (Do not use bleach and abrasive chemicals)

TROUBLESHOOTING

- THE APPLIANCE DOESN'T OPERATE**
1. Check if the appliance is plugged in.
 2. Check the electrical connections and voltage.
- THE APPLIANCE DOESN'T COOK WELL**
1. Check if it is operated at required heat or not.
- THE APPLIANCE STOPPED**
1. The appliance can stop due to low voltage. In this situation check the voltage.
 2. When the plates get too hot, they protect themselves and can be operated again after they cool down.

Troubleshooting — Error Code

ERROR	ERROR CODE	ERROR ANALYSIS
CIRCUIT FAULT	E0	Check the components and circuit board for damage.
EMPTY CONTAINER PROTECTION	E1	Is it an induction-suitable container?
LOW VOLTAGE PROTECTION	E2	Check if the voltage is low.
HIGH VOLTAGE PROTECTION	E3	Check if the voltage is low.
TEMPERATURE SENSOR NOT WORKING	E4	Check that the temperature sensor cable is not broken or disconnected.
OVERHEATING	E9	The internal fan of the circuit board is broken or the air intake is blocked.
MOTHERBOARD CONTROL PANEL NOT CONNECTING	EC	Check the cable connection between the motherboard and the display control card.

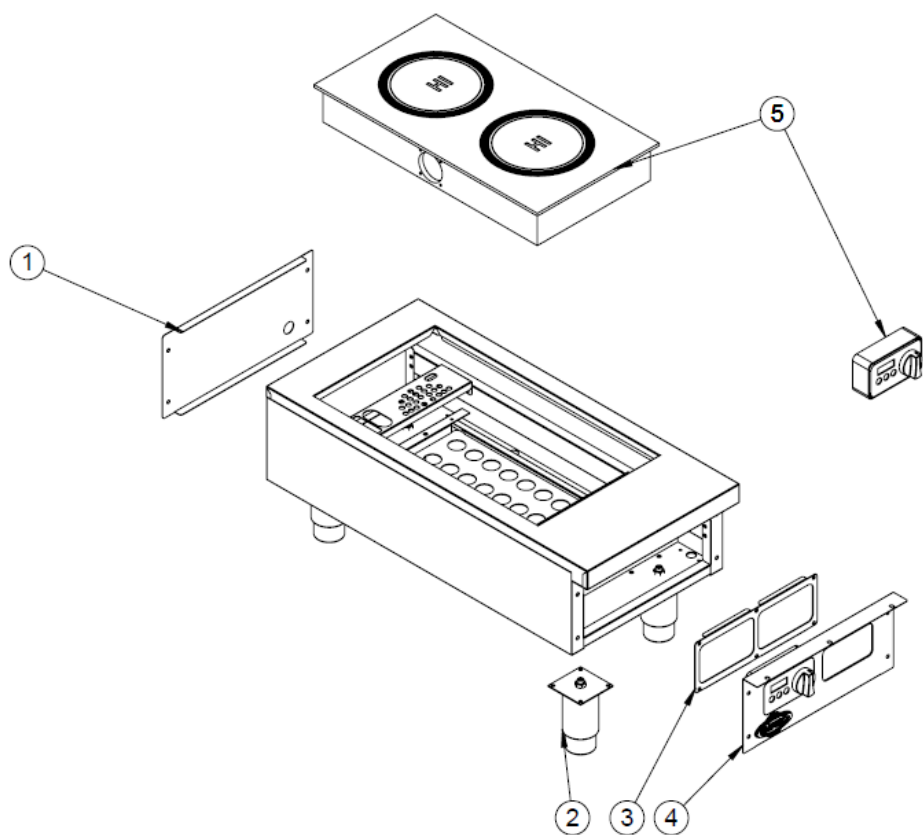

NO	PART CODE	TRACK NAME
1	YSC-KNX.PG7-LZ-1453	EMP.PLS.7IND010-USA BACK COVER SC
2	M.AKS-AYK-INX-001	13 CM CHROME PIPE FOOT ASSEMBLY-1
3	YSC-KNX.PG7-LZ-1454	EMP.PLS.7IND010-USA SCREEN SUPPORT SHEET
4	YSC-KNX.PG7-LZ-1452	EMP.PLS.7IND010-USA SET TOP FRONT PANEL SC
5	JP.M.MUH-070	208 V INDUCTION FURNACE 208V-60HZ-3000W (550*300*80) IMPORTED

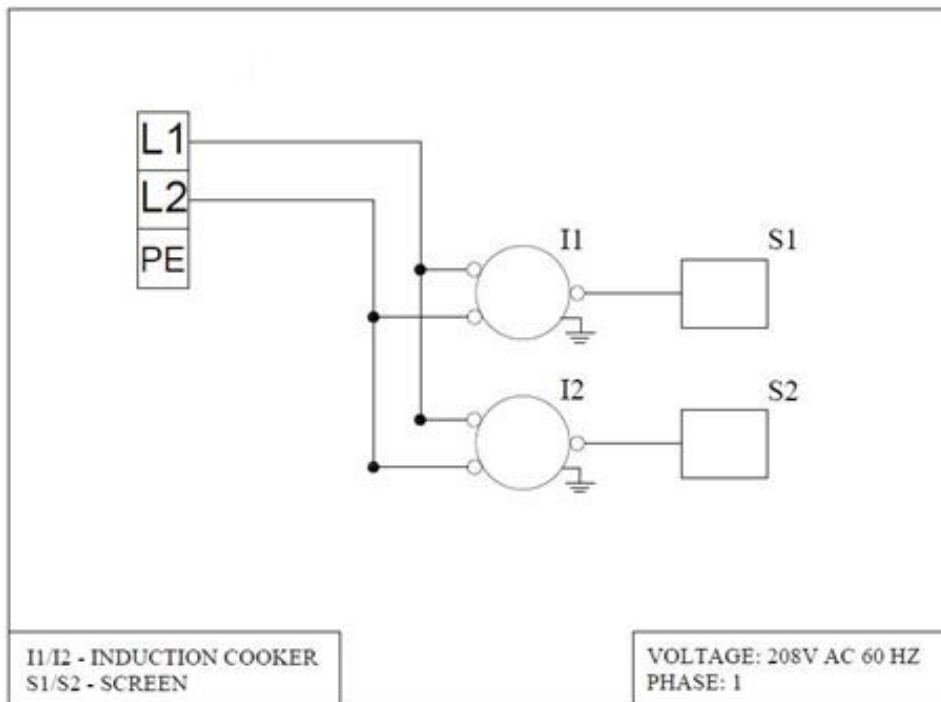

Warranty & Service

BakeMax provides a 1-Year Limited Parts and Labor warranty on most items, there are select items which carry a Limited 2-Year Warranty. Extended Warranty is available on some products. Please contact us for details. The Warranty is not transferable and is limited to original installation of equipment sold by BakeMax for the original user.

For all Warranty Claims, Proof of Purchase and/or Serial Number is required. Once the machine is approved, BakeMax will provide our customers with on-site Warranty Coverage on all equipment more than 100lbs. BakeMax assumes no responsibility for down time or loss of product. Repairs must be Pre-Authorized by BakeMax and have a Service Authorization Number issued prior to commencing Warranty Service.

Warranty begins 10-Days after shipping from warehouse; delays in installation which would extend the Warranty must be Approved. All equipment must be installed and connected by Qualified Professionals in accordance with the Manual Specification. Products shipped are to be inspected at time of delivery, the receiver is responsible for inspection.

Any abuse or improper use of the equipment will void the warranty. This includes failure to follow all cleaning instructions, improper installation, improper maintenance, failure to follow capacity charts, improperly wired electrical connections. The Warranty does not apply to abuse, willful or accidental damage, or to products used for other than their intended purpose. Normal wear parts such as Accessories, Attachments, or Electrical Components such as Fuses, Bulbs, Elements, and Switches carry a 90-Day Warranty only.

Bench Warranty (Machines Weighing 100 lb. or less)

Once the machine is Approved for Warranty Service, if the machine requires Warranty work in less than 30 days of purchase date, BakeMax will pay all shipping charges. Once the machine is received and repaired it will be returned to the user at BakeMax expense. Freight Damages during return shipping is the responsibility of the owner of the machine.

The following is not covered under the BakeMax Warranty:

1. Overtime Labor Rates are not covered by BakeMax.
2. All parts will be shipped via Ground Courier only; If Express Shipping is required, it will be the responsibility of the Customer or Dealer.
3. Travel for Warranty Service is covered up to 100 Miles /160 Km Roundtrip, any further mileage will be the responsibility of the Customer or Dealer.
4. There is no on-site Warranty Service for Residential Addresses or addresses outside of the contiguous United States (Lower 48) or Canada.

***BakeMax machines sold outside of the contiguous United States (Lower 48), or Canada will carry 1-Year Parts Warranty only.*

Questions? OEM Parts?
Toll Free: 1-800-565-2253
Email: info@BakeMax.com
www.BakeMax.com

BakeMax[®]
www.BakeMax.com