

BakeMax BMPM007 7 Quart Planetary Mixer Operations Manual



Questions? OEM Parts, Contact Us:

Toll Free: 1-800-565-2253

Email: Info@BakeMax.com

www.BakeMax.com



Warning & Safety

PLEASE READ AND FOLLOW INSTRUCTIONS BELOW TO PREVENT INJURY OR DAMAGE TO THE PRODUCT

BakeMax[®] (a registered trademark of Titan Ventures International Inc or TVI) is not responsible for any harm or injury caused due to any person's improper or negligent use of this equipment. The product shall only be operated by someone over the age of 18, of sound mind, and not under the influence of any drugs or alcohol, who has been trained in the correct operation of this machine, and is wearing authorized, proper safety clothing. This machine is intended for commercial use only. Any modification or miss use to the machine voids any warranty and may cause harm to individuals using the machine or in the area of the machine while in operation.

- When using the machine, please ensure that you have read all of the instructions within this manual.
- Be aware of your surroundings when using this machine, ensure there are no children or any other persons who are near the machine before operating.
- Do not put hand near moving parts.
- Remove all obstacles, which may interfere with machine functions.
- Keep work area clean and clear of clutter.
- Do not sit or stand on machine.
- Do not wear loose clothing or jewelry when operating machine as it may get caught in moving parts and cause injury.
- Stop using the machine and have it checked by an authorized service personal if it is not working properly.
- Disconnect from power source before performing and maintenance or cleaning on the machine.
- When the machine is not in use, please clean and store properly,
- Do not place any electrical parts or plug / cord in water or liquid.
- If the supply cord is damaged it must be replaced by an authorized service agent in order to avoid any electrical hazards.
- Keep power cord away from heat.
- Always ensure to follow local laws when operating your machine.

Cleaning

- This unit has been coated for shipping purposes, please clean before use.
- Do not use any liquid pressurized cleaning equipment on this machine.
- Disconnect power supply before cleaning.
- Only use food grade nonabrasive cleaning agents.
- Follow any additional cleaning / maintenance listed below.

Features:

The BakeMax BMPM007 - 7Qt Planetary Mixer is designed to work as a countertop unit. With its space saving design and digital speed control, it provides durability, long life and excellent mixing performance. It's safe, easy to use and capable of a broad range of food mixing applications.

- 100% Gear Driven
- Professional Countertop Style
- Motor Offers enough Power to Mix Stiffer Doughs and Larger Batches
- 30 Minute Digital Timer
- All Metal and Die-Cast Aluminum Body
- Transmission is made of Hardened alloy Steel Gears
- All Shafts are mounted in Ball Bearings
- Automatic Electronic 5 speed control (100 to 500 RPM.)
- Planetary Mixing Action ensures Perfect Results
- Simple Hand Lift Tool for attachment change and Bowl Removal
- Includes Dough Hook, Flat Beater and Wire Whip
- Safety Guard is Standard for Model BMPM007 and provides with automatic shut-off when guard is opened at any speed.
- 1-Year Limited Warranty

Technical Specifications:

- Exterior Dimensions (WDH): 18.1" x 13.4" x 20.5"
- 110V / 6A / 650W / 60Hz / 1Ph
- Plug & Go Nema 5-15P Plug
- Net Weight 45 lbs.

Shipping Specifications:

- Packaged Dimensions (WDH): 20" x 15" x 24"
- Packaged Weight 50 lbs.

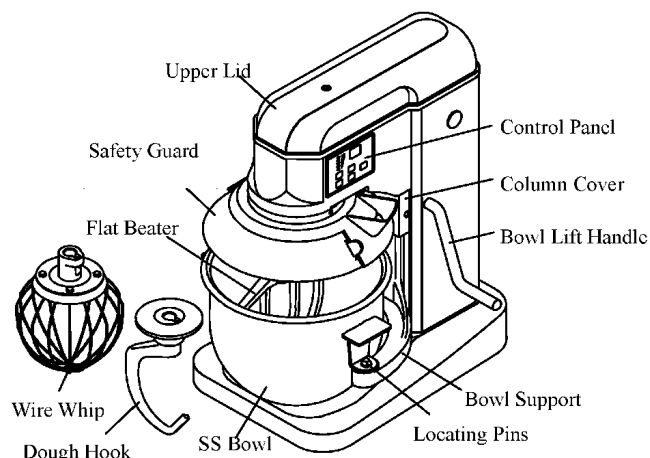

CONTROLS

All models are furnished with a digital Timer and electronic 5-speed

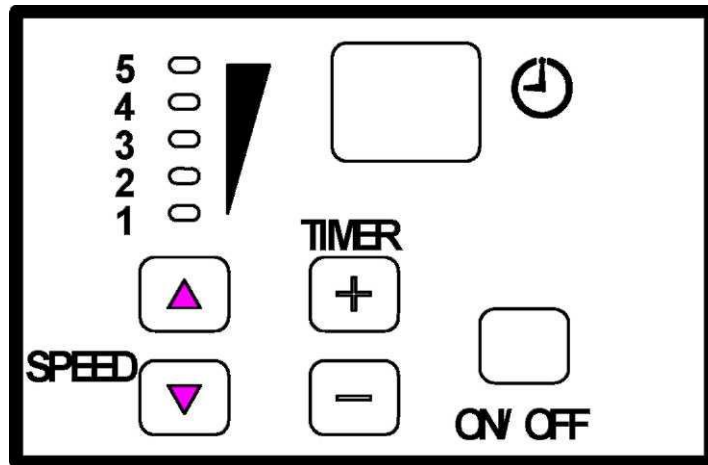

Timer:

Digital set by 1-30 minutes or non-timer service.

Speed:

Speed 1 - For slow beating, mashing and kneading yeast dough. Speed 2 - For mixing cookie and cake batters. Speed 3 - For beating, creaming and medium fast whipping. Speed 4 - For whipping heavy cream, egg whites and boiled frostings. Speed 5 - For whipping small amounts of heavy cream and egg whites.

HOW TO INSTALL AN AGITATOR

To install an agitator, the bowl must be installed and fully lowered. Place the agitator in the bowl, push it up on the agitator shaft, and turn it clockwise to seat the shaft pin in the slot of the agitator shank.

HOW TO INSTALL A BOWL

The bowl must be installed before the agitator. To install the bowl, fully lower the bowl support. Position the bowl so the alignment bracket on the back of the bowl is in the bowl retainer and the locating pins on the front of the bowl support fit in the holes on the sides of the bowl.

MAINTENANCE

NOTE: ALL MAINTENANCE WORK SHOULD BE DONE ONLY AFTER UNIT HAS BEEN DISCONNECTED FROM ELECTRICAL POWER AND GROUNDING.

Never use a metal or stiff brush to clean the mixer. Never clean the mixer with a water hose or any fluid pressure.

- The mixer should be thoroughly cleaned after using.
- Bowls and agitators should be removed from the mixer and cleaned.
- The transmission case and planetary gears are filled special grease that will last for several years. When grease is needed for replacement, it should be ordered from our authorized service representative.
- If the attachment strikes bowl, stop the mixer. The original seller will help you to make adjustment.

If your mixer should malfunction or fail to operate, check the following.

- Is the mixer plugged in?
- Is the fuse in the circuit to the mixer in working order? If you have a circuit breaker box, be sure the circuit is closed.
- If the problem is not due to one of the above items, please contact your dealer.



Mixing Dough & Capacity Information

The moisture content of heavy dough is a critical factor when selecting proper mixing speed. You should never use 2nd speed when mixing heavy dough with an Absorption Ratio (AR) of 50% or less. To determine the Absorption Ratio (AR) of a product, divide the water weight by the flour weight.

Example: Calculate the Absorption Ratio of a mixture containing 10 lbs. Of flour and 5 lbs. of water.
 $10 / 5 = 0.50 = 50 \% = AR$

PRODUCT	TOOL	BMPM007	BMPM012	BMPM020 / BMPM20A	BMPM030	BMPM040	BMPM060	BMPM080	BMPM120
Egg Whites	Whip	0.4 qts.	0.63 qts.	1 qts.	1.5 qts.	2 qts.	3.1 qts.	4.2 qts.	3.6 qts.
Mashed Potatoes	Beater	4 lbs.	10 lbs.	15 lbs.	22 lbs.	29 lbs.	40 lbs.	60 lbs.	90 lbs.
Mayonnaise (qts. Oil)	Beater	3 qts.	4 qts.	8.5 qts.	12.7 qts.	13.7 qts.	19 qts.	31.7 qts.	40 qts.
Meringue (qts. Water)	Whip	0.25 qts	0.42 qts.	0.75 qts.	1 qts.	1.5 qts.	2 qts.	3 qts.	4 qts.
Waffle/Pan cake Batter	Beater	3 qts.	4.5 qts.	7.5 qts.	12 qts.	16 qts	23 qts	32 qts.	NA
Whipped Cream	Whip	1.8 qts.	2 qts.	4 qts.	6 qts.	9 qts	12 qts	16 qts.	25 qts.
Cup Cake / Layer Cake	Beater	6 lbs.	11 lbs.	20 lbs.	30 lbs.	44 lbs.	60 lbs.	88 lbs.	120 lbs.
Sponge Cake (w/ Flour & Butter)	Whip	4 lbs.	7.5 lbs.	13 lbs.	22 lbs.	26.5 lbs.	44 lbs.	80 lbs.	120 lbs.
Sugar Cookie	Beater	3 lbs.	10 lbs.	14 lbs.	22 lbs.	30 lbs.	40 lbs.	60 lbs.	80 lbs.
Bread or Roll Dough (Light/ Medium, 60% AR)	Hook	3 lbs.*	4.4 lbs. of Flour*	10 lbs. of Flour*	16.5 lbs. of Flour*	30 lbs. of Flour**	55 lbs. of Flour**	77 lbs. of Flour**	160 lbs. of Dough Total
Bread or Roll Dough (Heavy, 55% AR)	Hook	2 lbs.*	3.75 lbs. of Flour*	8 lbs. of Flour*	14.5 lbs. of Flour*	24.5 lbs. of Flour**	49 lbs. of Flour**	66 lbs. of Flour**	120 lbs. of Dough Total
Thin Pizza Dough, Pasta, Basic Egg Noodle (40% AR, Max 5 Minutes of Mixing Time)	Hook	2 lbs.*	3.3 lbs. of Flour*	6.5 lbs. of Flour*	13.5 lbs. of Flour*	22 lbs. of Flour*	44 lbs. of Flour*	55 lbs. of Flour*	80 lbs. of Dough Total
Medium Pizza Dough (50% AR)	Hook	2.5 lbs.*	3.3 lbs. of Flour*	6.5 lbs. of Flour*	13.5 lbs. of Flour*	22 lbs. of Flour*	44 lbs. of Flour**	55 lbs. of Flour**	90 lbs. of Dough Total
Thick Pizza Dough (60% AR)	Hook	3 lbs.*	4.4 lbs. of Flour*	10 lbs. of Flour*	16.5 lbs. of Flour*	30 lbs. of Flour**	55 lbs. of Flour**	77 lbs. of Flour**	100 lbs. of Dough Total
Raised Donut Dough (65% AR)	Hook	2.5 lbs.*	3.3 lbs. of Flour*	6.5 lbs. of Flour*	13.5 lbs. of Flour*	22 lbs. of Flour*	44 lbs. of Flour*	55 lbs. of Flour*	70 lbs. of Dough Total
Whole Wheat Dough (70% AR)	Hook	3 lbs.*	4.4 lbs. of Flour*	10 lbs. of Flour*	16.5 lbs. of Flour*	30 lbs. of Flour**	55 lbs. of Flour**	77 lbs. of Flour**	120 lbs. of Dough Total

Speeds:

- *1st Speed Only
- **1st Speed & 2nd Speed Only

Notes:

- If using high gluten or rice flour, please reduce capacity by 10%.
- If using water colder than 70°F, ice or chilled flour, please reduce capacity by 10%.
- Attachment hub should not be used while mixing.
- Mixer should be powered off when changing speeds

Capacity Conversion

- *1 Gallon of Water Weights 8.33 lbs.
- *1 Liter of Water Weights 1 kg or 2.2 lbs.
- *1 lb = 0.454 kg / 1 kg = 2.2 lbs.
- *1 US Liquid Quart = 0.946 Liters

This chart should be used as a guide only. Type of flour and other factors can vary and may require batch size to be adjusted.

Warranty & Service

BakeMax provides a 1-Year Limited Parts and Labor warranty on most items, there are select items which carry a Limited 2-Year Warranty. Extended Warranty is available on some products. Please contact us for details. The Warranty is not transferable and is limited to original installation of equipment sold by BakeMax for the original user.

For all Warranty Claims, Proof of Purchase and/or Serial Number is required. Once the machine is approved, BakeMax will provide our customers with on-site Warranty Coverage on all equipment more than 100lbs. BakeMax assumes no responsibility for down time or loss of product. Repairs must be Pre-Authorized by BakeMax and have a Service Authorization Number issued prior to commencing Warranty Service.

Warranty begins 10-Days after shipping from warehouse; delays in installation which would extend the Warranty must be Approved. All equipment must be installed and connected by Qualified Professionals in accordance with the Manual Specification. Products shipped are to be inspected at time of delivery, the receiver is responsible for inspection.

Any abuse or improper use of the equipment will void the warranty. This includes failure to follow all cleaning instructions, improper installation, improper maintenance, failure to follow capacity charts, improperly wired electrical connections. The Warranty does not apply to abuse, willful or accidental damage, or to products used for other than their intended purpose. Normal wear parts such as Accessories, Attachments, or Electrical Components such as Fuses, Bulbs, Elements, and Switches carry a 90-Day Warranty only.

Bench Warranty (Machines Weighing 100 lb. or less)

Once the machine is Approved for Warranty Service, if the machine requires Warranty work in less than 30 days of purchase date, BakeMax will pay all shipping charges. Once the machine is received and repaired it will be returned to the user at BakeMax expense. Freight Damages during return shipping is the responsibility of the owner of the machine.

The following is not covered under the BakeMax Warranty:

1. Overtime Labor Rates are not covered by BakeMax.
2. All parts will be shipped via Ground Courier only; If Express Shipping is required, it will be the responsibility of the Customer or Dealer.
3. Travel for Warranty Service is covered up to 100 Miles /160 Km Roundtrip, any further mileage will be the responsibility of the Customer or Dealer.
4. There is no on-site Warranty Service for Residential Addresses or addresses outside of the contiguous United States (*Lower 48*) or Canada.

***BakeMax machines sold outside of the contiguous United States (*Lower 48*), or Canada will carry 1-Year Parts Warranty only.*

Terms & Conditions

Terms

Net 15 days subject to Credit Approval. All past due Accounts are subject to 2% per month Service Charge as per Credit Application. We accept Visa, MasterCard, and Discover Credit Cards. We also accept E-Transfer & Wire Transfer, additional fees may apply.

Pricing

All prices are subject to change without notice. All prices are Sales Tax Extra, should you be claiming Tax Exemption, Tax Exempt Forms must accompany your Purchase Order. BakeMax products are sold in Canadian and US Dollars. BakeMax is not responsible for specifications errors or printing errors.

Shipping

Free shipping to Canada and the U.S. Minimum order \$6,000 for BakeMax and \$10,000 for BakeMax America Cooking Line. Tailgate Delivery is \$90.00 minimum. All checks made Payable to Titan Ventures International Inc. BakeMax is not responsible for goods damaged during shipping. BakeMax is not responsible for any delays in delivery once product has left our Warehouse and is in the carrier's possession. Products shipped are to be inspected at time of delivery, the receiver is responsible for inspection. Damaged Freight Claims are to be claimed with the carrier. BakeMax assumes no responsibility for Damaged Freight. Shipping Insurance available by request. By signing your name on the delivery receipt without noting any damages, you are stating that you have received your shipment in Acceptable Condition.

Return Policy

Returns will not be Approved unless in Writing. Returns must be made within 30-Days of Purchase and must have a Return Authorization Number issued before returning. The purchase order number, reason for return, and the serial number(s) of the unit are required for the Return Authorization Number. Minimum return amount of \$100.00.

Returns are subject to a minimum restocking fee of 30%. The cost of any repairs or re-creating required will be charged back to the dealer. If there is a manufacturer's defect BakeMax® will pay standard freight returned and prepaid shipping back to the customer.

Special Order Items, Clearance / Discontinued Equipment, Parts, Refurbished/Demo Equipment, or Non-Standard items are not Returnable.

Ordering Information

Send purchase orders to BakeMax via e-mail orderdesk@bakemax.com or Fax (506-859-6929). Use Model or Part number when ordering including Voltage Requirements, and Product Description. Please include the Dealer, Name, Address, terms, special delivery, or instructions required or attention names to be applied to packaging. Please notify BakeMax should you need order confirmation or tracking numbers, by calling 1-800-565-2253 or email orderdesk@bakemax.com.

Special Terms and Conditions

BakeMax reserves the right to make improvements or equipment changes without prior permission. Setup and Installation are the end user's Responsibility. Failure to properly Install or Maintain Equipment may Void Warranty.

Catalog, Spec Sheets and Website

BakeMax is not liable for incorrect information found in our Catalog, Spec Sheets or Website. Please contact us to confirm specifications. Pictures and specifications are for general purposes only. Product may not be exactly as shown. Prices and availability may change at any time without notice. Dimensions shown may change at any time without notice.