

Image 1

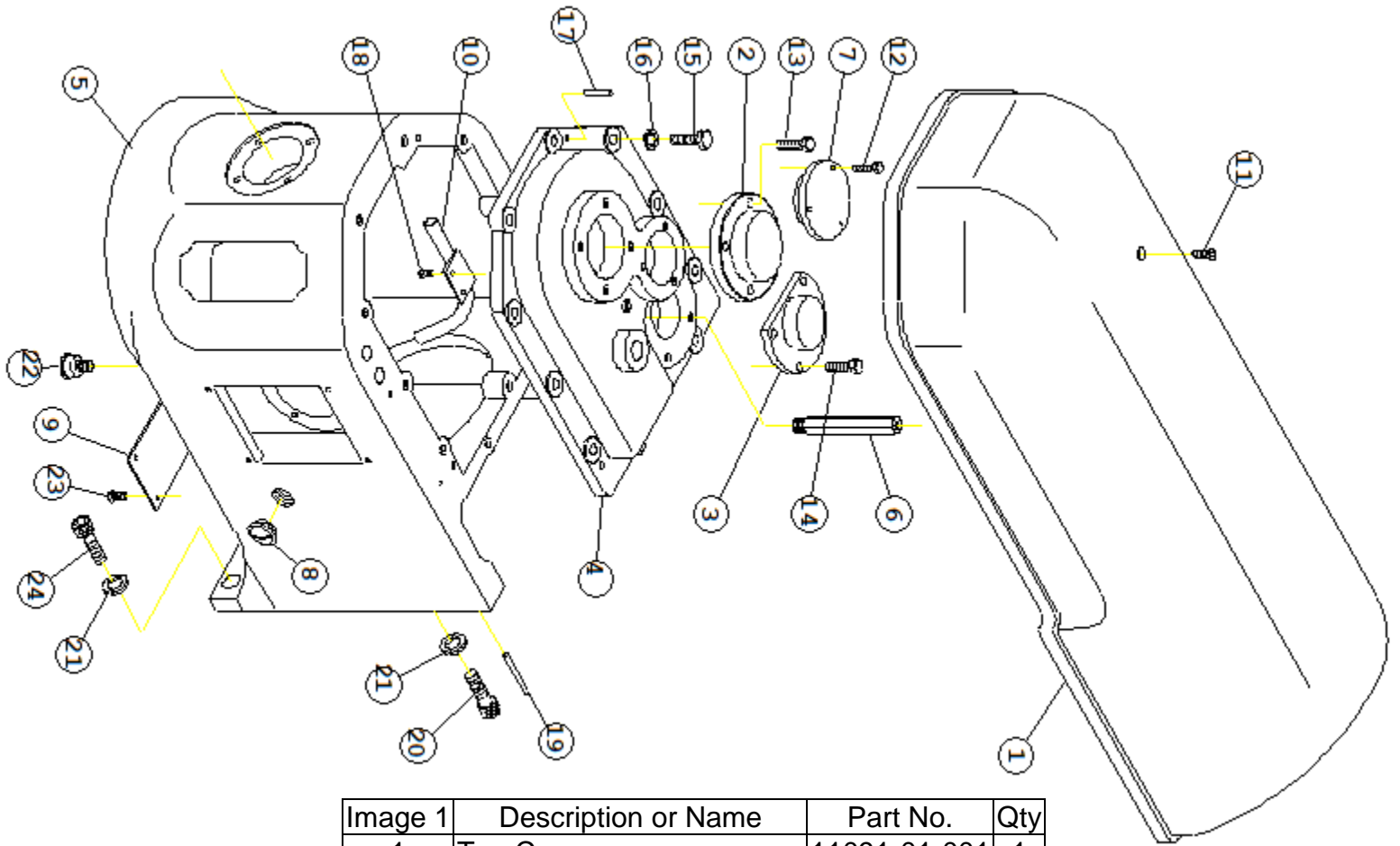

Image 1	Description or Name	Part No.	Qty
1	Top Cover	11091-01-001	1
2	Planetary Bearing Retainer	11091-01-002	1
3	Bearing Retainer	11091-01-003	1
4	Gear Housing Cover	11091-01-004	1
5	Transmission Case	11091-01-005	1
6	Support of Top Cover	11091-01-006	1
7	Bearing Retainer	11091-01-007	1
9	Plate	11091-01-009	1
10	Oil Delivery Tube	11091-01-010	1
11	Mach Screw 1/4" * 3/4"	S+F1/4*3/4	1
12	Bolt 1/4" * 5/8"	S-1/4*5/8	3
13	Bolt 5/16" * 3/4"	S-5/16*3/4	4
14	Bolt 5/16" * 1"	S-5/16*1	4
15	Bolt 3/8" * 1-1/4"	S-3/8*1-1/4	11
17	Spring Pin 6*28	SPP-6*28	2
18	Mach Screw 3/16" * 3/4"	S+R3/16*3/4	2
19	Spring Pin 10*50	SPP-10*50	2
20	Cap Screw 1/2" * 2-1/4"	S-C-1/2*2-1/4	4
21	Spring Washer 1/2"	SW-1/2	6
22	Plug	712-050	1
23	Mach Screw 3/16" * 3/8"	S+R3/16*.3/8	4
24	Cap Screw 1/2" * 1-1/4"	S-C-1/2*1-1/4	2

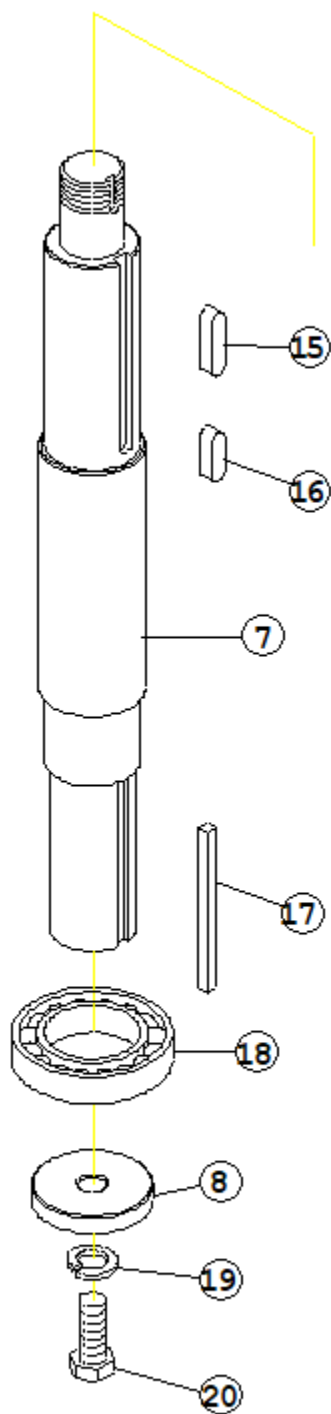

Image 2

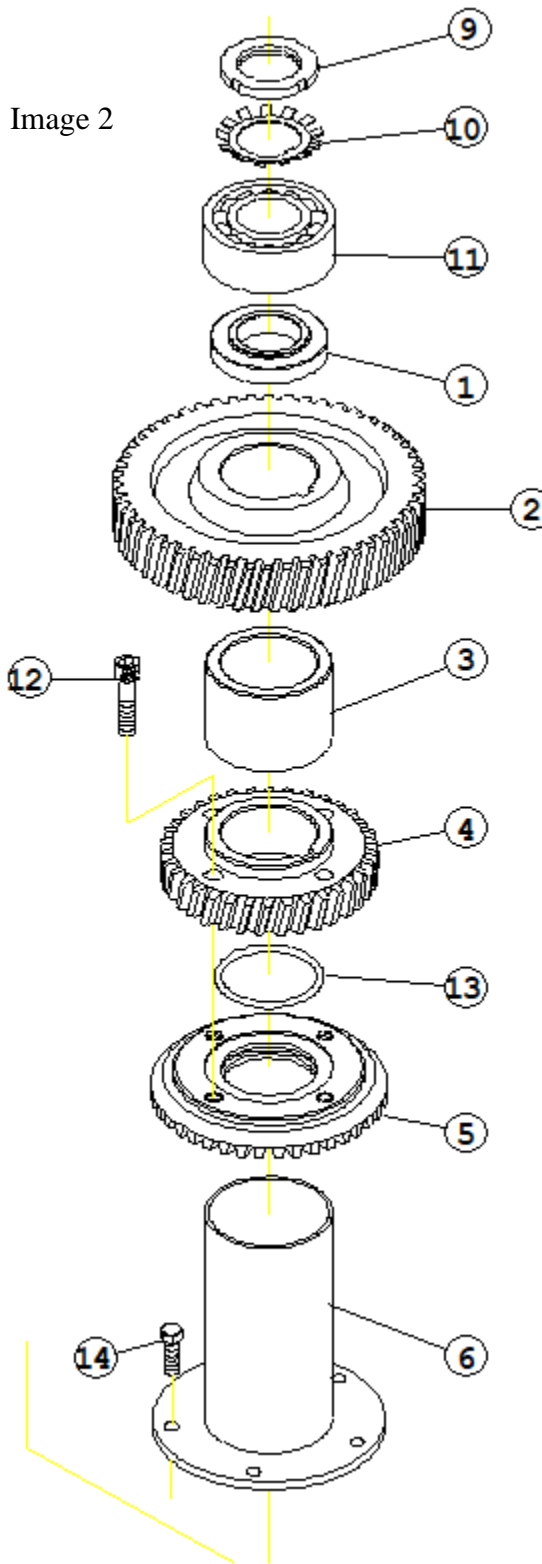

Image 2	Description or Name	Part No.	Qty
1	Shim	11091-02-001	1
2	Gear (53 T)	11091-02-002	1
3	spacer	11091-02-003	1
4	Gear (35T)	11091-02-004	1
5	Bevel Gear (41 T)	11091-02-005	1
6	Chimney	11091-02-006	1
7	Planetary Shaft	11091-02-007	1
8	Washer	11091-02-008	1
9	Lock Nut M30	MN30	1
10	Lock Washer 30	M30	1

Image 2	Description or Name	Part No.	Qty
11	Ball Bearing 5206Z	BR-5206Z	1
12	Cap Screw 5/16" *1-1/4"	S-C-5/16*1-1/4	4
13	O Snap Ring P45	OR-P45	1
14	Mach Screw 1/4" *5/8"	S+F1/4*5/8	5
15	Key 8*8*38	KR-8*8*38	1
16	Key 8 *8 *27	KR-8*8*27	1
17	Key 1/4" *1/4" *95	KR-1/4*1/4*95	1
18	Ball Bearing 6009Z	BR-6009Z	1
19	Spring Washer 1/2"	SW-1/2	1
20	Cap Screw 1/2" *1"	S-C-1/2*1	1

Image 3

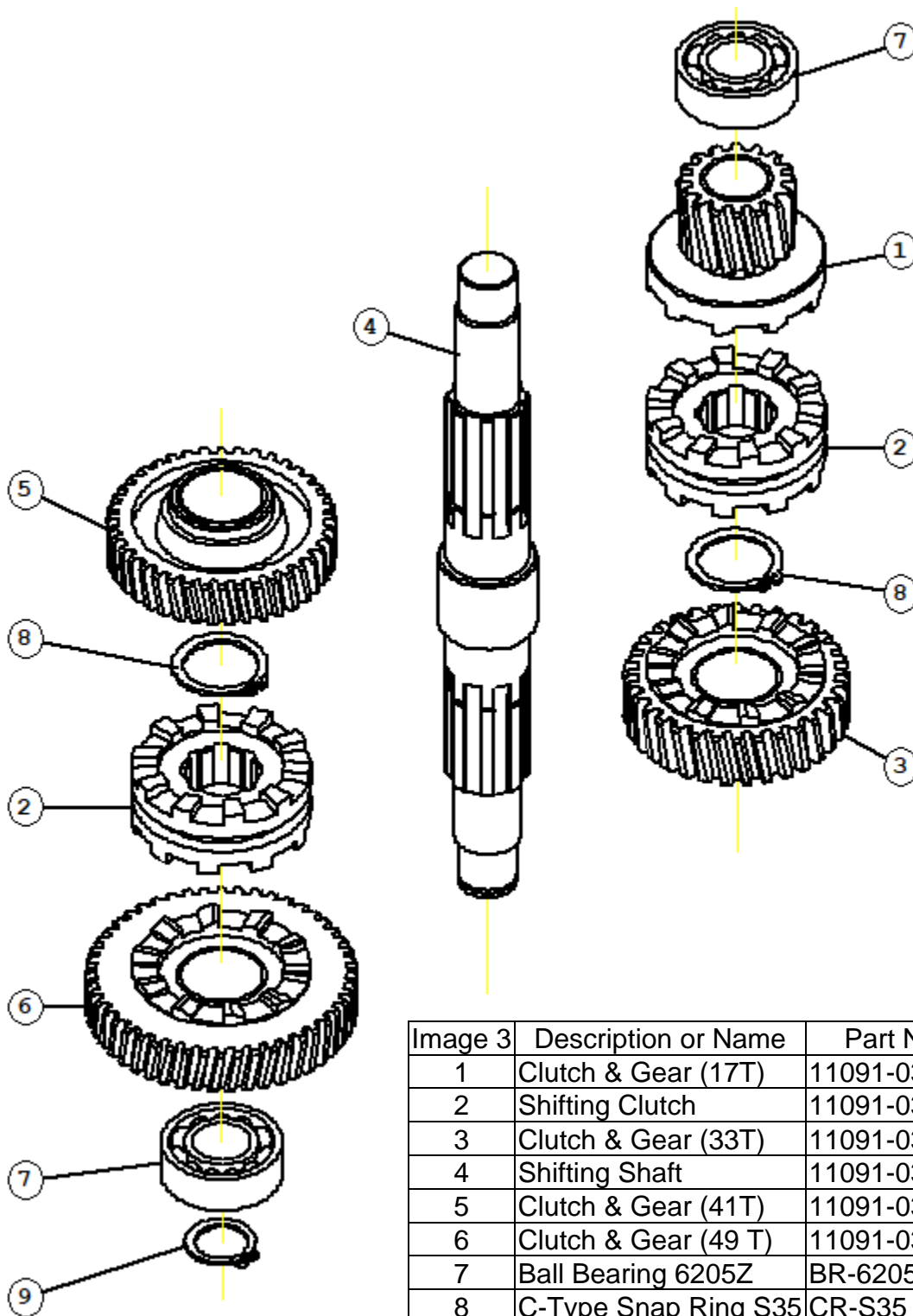

Image 3	Description or Name	Part No.	Qty
1	Clutch & Gear (17T)	11091-03-001	1
2	Shifting Clutch	11091-03-002	1
3	Clutch & Gear (33T)	11091-03-003	1
4	Shifting Shaft	11091-03-004	1
5	Clutch & Gear (41T)	11091-03-005	1
6	Clutch & Gear (49 T)	11091-03-006	1
7	Ball Bearing 6205Z	BR-6205Z	2
8	C-Type Snap Ring S35	CR-S35	2
9	C-Type Snap Ring S25	CR-S25	1
10	Spacer	11091CU2	2
11	Spacer	11091CU1	2

Image 4

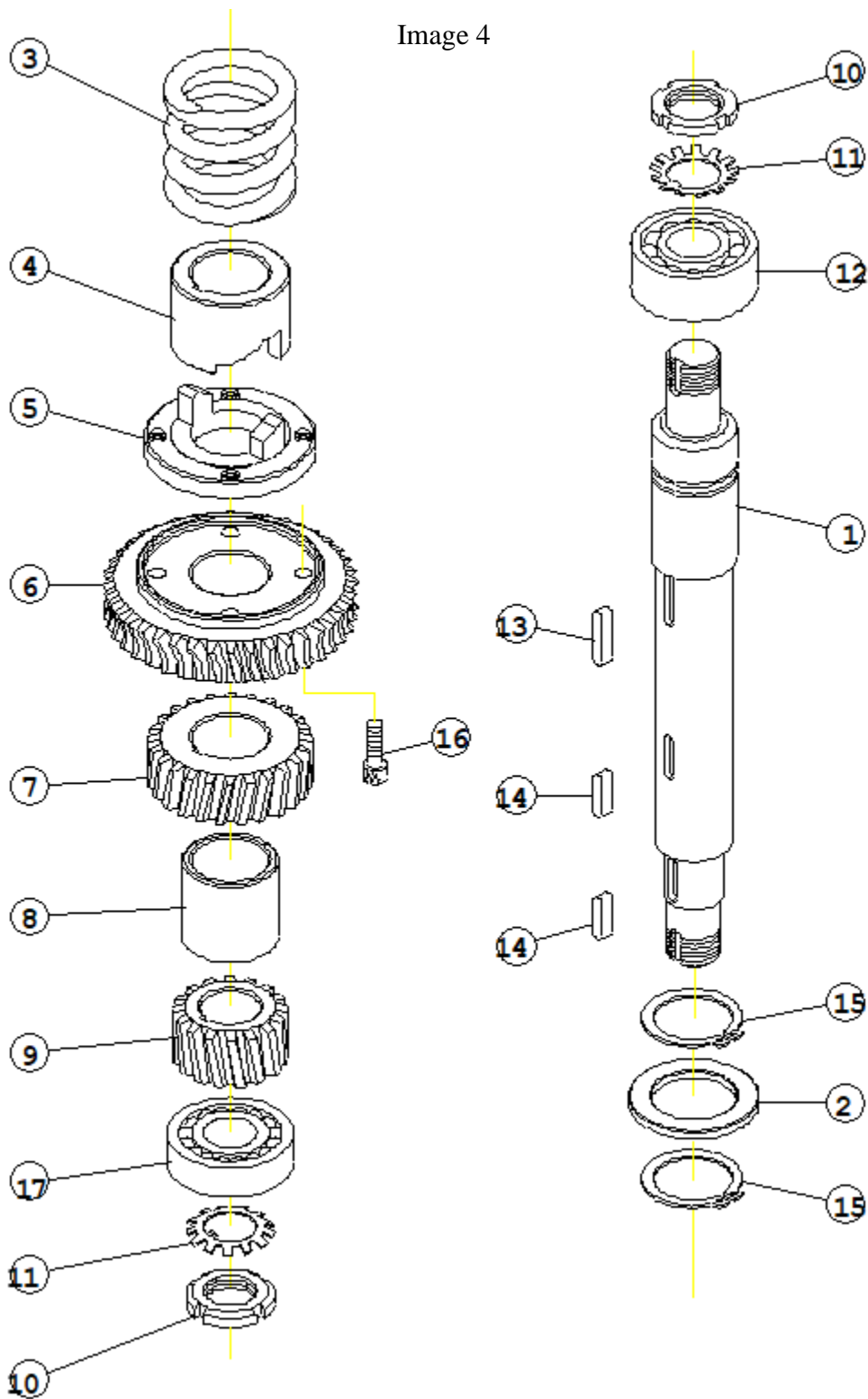

Image 4	Description or Name	Part No.	Qty
1	Worm Gear Shaft	11091-04-001	1
2	Spacer	11091-04-002	1
3	Compression Spring	11091-04-003	1
4	Compressor-Shock	11091-04-004	1
5	Flange-Shock	11091-04-005	1
6	Worm Gear	11091-04-006	1
7	Gear (25 T)	11091-04-007	1
8	Spacer	11091-04-008	1
9	Gear (17T)	11091-04-009	1

Image 4	Description	Part No.	Qty
10	Lock Nut M20	MN20	2
11	Lock Washer 20	M20	2
12	Ball Bearing 5204Z	BR-5204Z	1
13	Key 5*5*25	KRR-5*5*25	1
14	Key 5*5*20	KRR-5*5*20	2
15	C-Type Snap Ring S32	CR-S32	2
16	Cap Screw 1/4" *1"	S-C-1/4*1	4
17	Ball Bearing 1204	BR-1204	1

Image 5

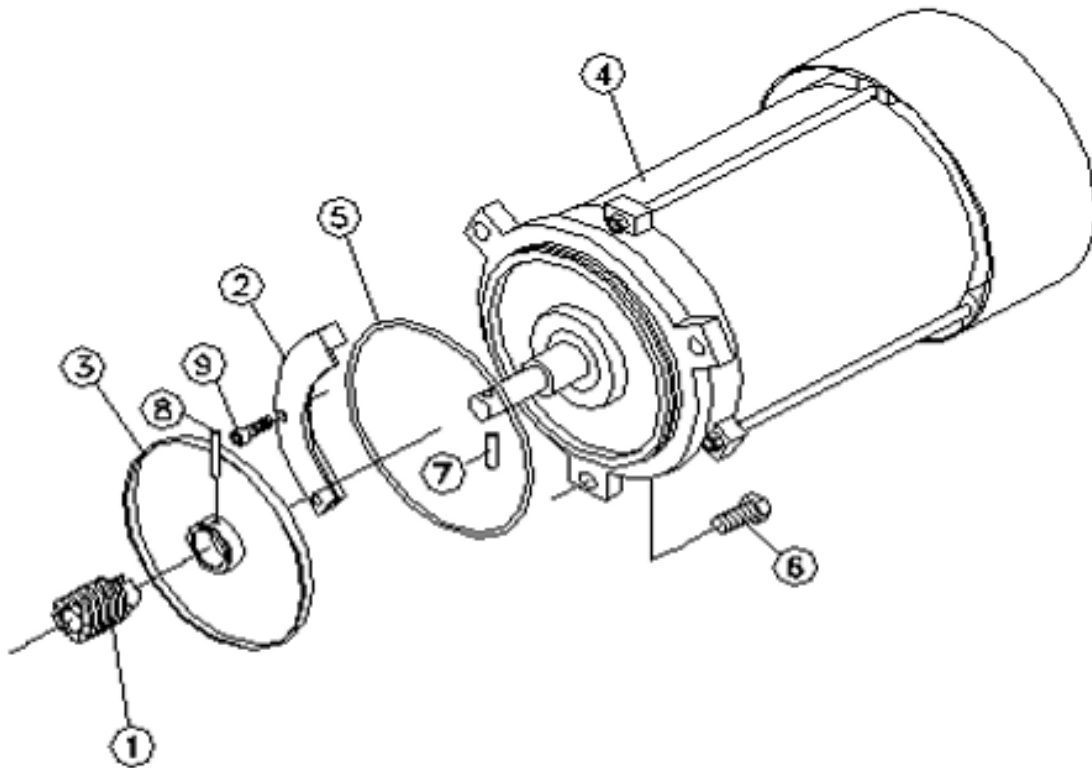

Image 5	Description or Name	Part No.	Qty
1	Worm	11091-05-001	1
2	Guide of Oil Flinger	11091-05-002	1
3	Flinger & Hub	11091-05-003	1
4	Motor	11091-05-004	1
5	O Snap Ring 175*3.5	OR-175*3.5	1
6	Bolt 1/2*1-1/2	S-1/2*1-1/2	3
7	PARALLEL PIN 6*29	PARALLELPIN-6*29	1
8	Spring Pin 6*40	SPP-6*40	1
9	Cap Screw 5/16*1	S-C-5/16*1	2

Image 6

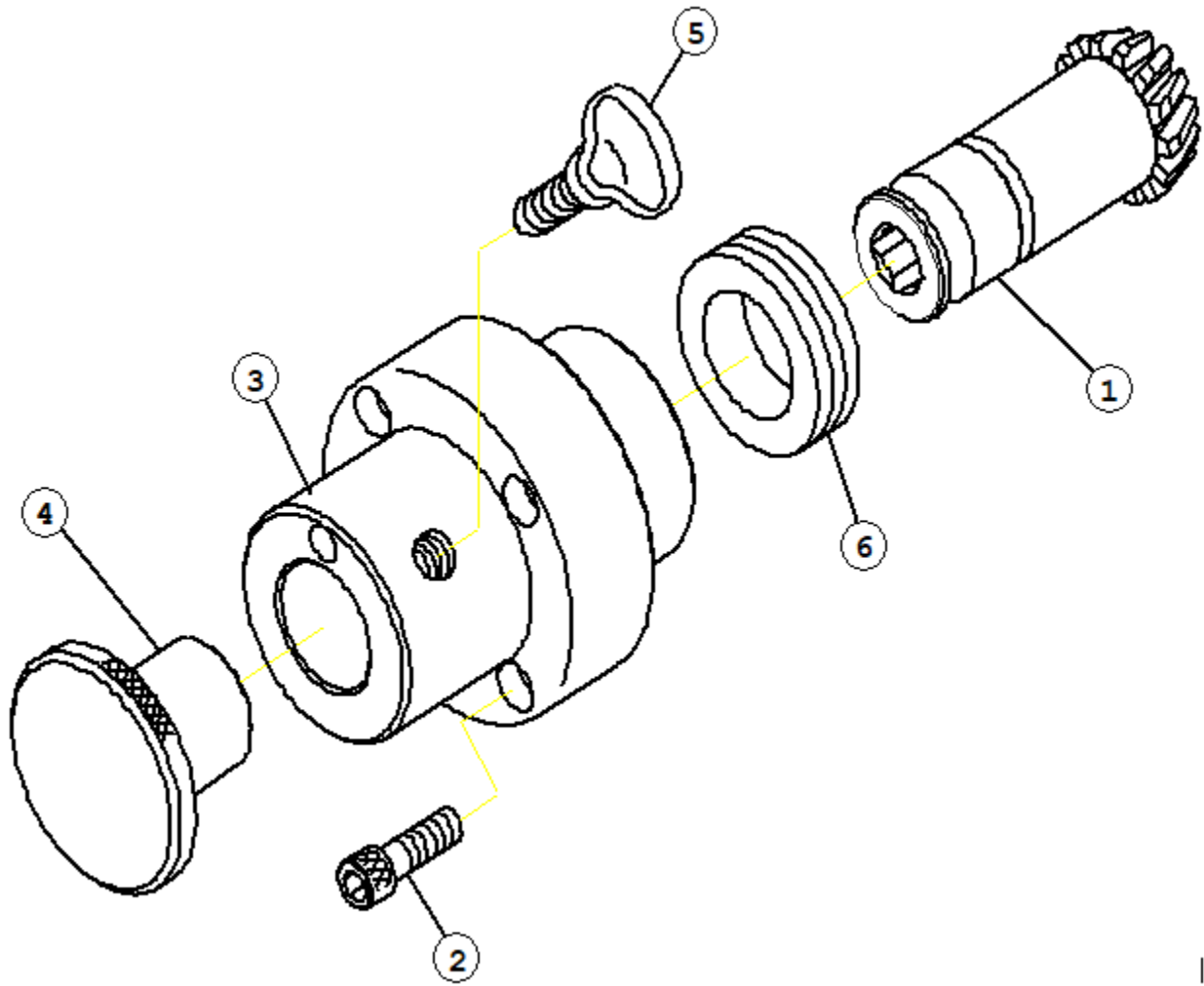

Image 6	Description or Name	Part No.	Qty
1	Bevel Pinion (16T)	11091-06-001	1
2	Cap Screw 5/16" *1-1/4"	S-C-5/16*1-1/4	4
3	Hub Attachment	11091-06-003	1
4	Attachment Hole Plug	11091-06-004	1
5	Thumb Screw	11031-06-005	1
6	Ball Bearing 2907	BR-2907	1

Image 7

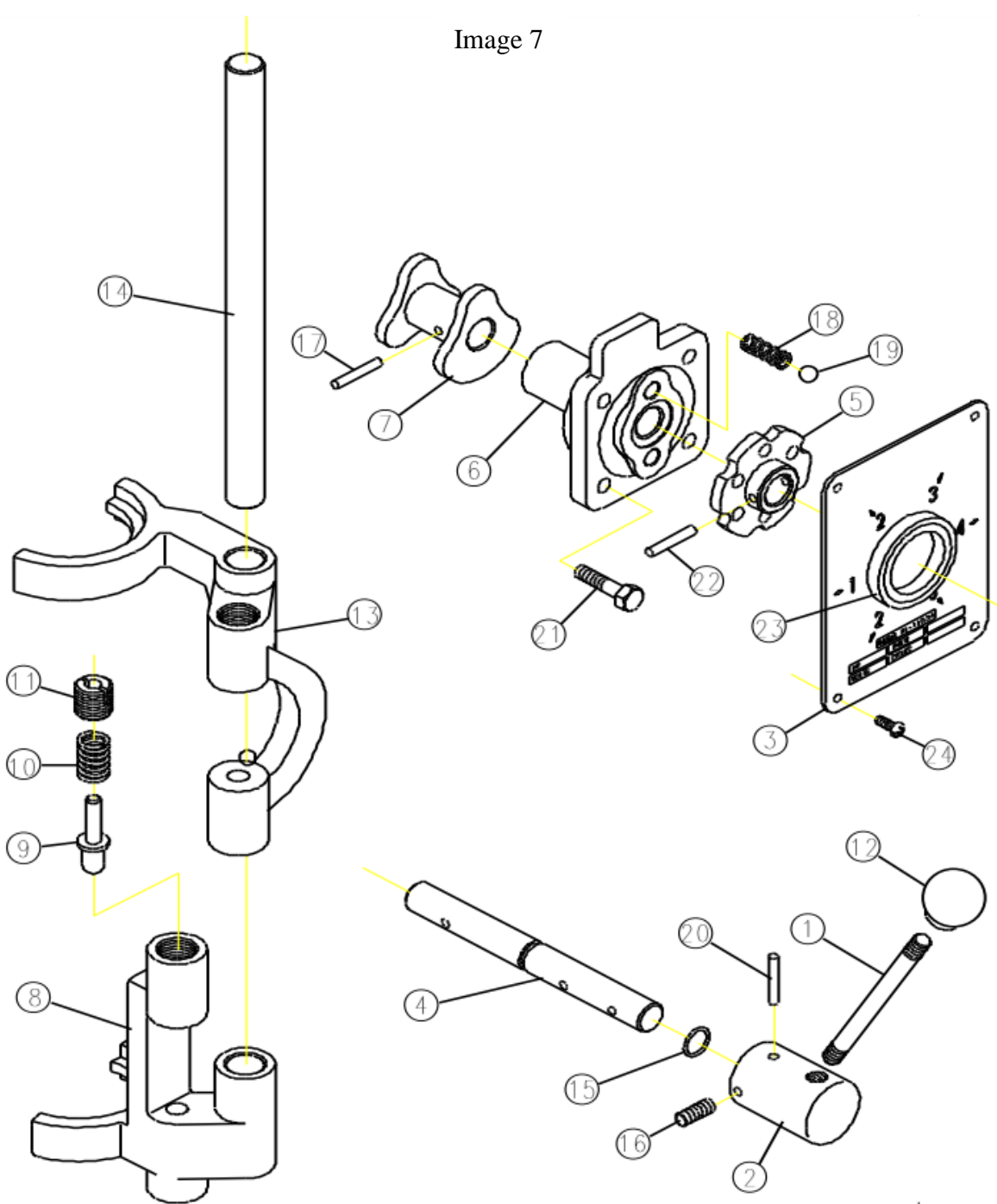

Image 7	Description or Name	Part No.	Qty
1	Shift Handle	11091-07-001	1
2	Handle Base	11091-07-002	1
3	Control Panel	11091-07-003	1
4	Shaft	11091-07-004	1
5	Hub & Cam	11091-07-005	1
6	Bracket Gear Shift	11091-07-006	1
7	Shift Cam	11091-07-007	1
8	Lower Shifting Fork	11091-07-008	1
9	Shift Fork Plunger	11091-07-009	4
10	Compression Spring	11091-07-010	4
11	Screw	11091-07-011	4
12	Shift Handle Knob	11091-07-012	1

Image 7	Description	Part No.	Qty
13	Upper Shifting Fork	11091-07-013	1
14	Shifter Fixed Shaft	11091-07-014	1
15	O Snap Ring P12	OR-P12	1
16	Set Screw 1/4" * 3/8"	S-S1/4*3/8	1
17	Spring Pin 6*24	SPP-6*24	1
18	Compression Spring	11091-07-018	2
19	Steel Ball 8	SB-8	2
20	Spring Pin 5*36	SPP-5*36	1
21	Bolt 5/16" * 5/8"	S-5/16*5/8	4
22	Spring Pin 5*28	SPP-5*28	1
23	Oil Seal TC38*50*08	OS-TC38*50*08	1
24	Mach Screw 3/16" * 3/8"	S+R3/16*3/8	4

Image 8

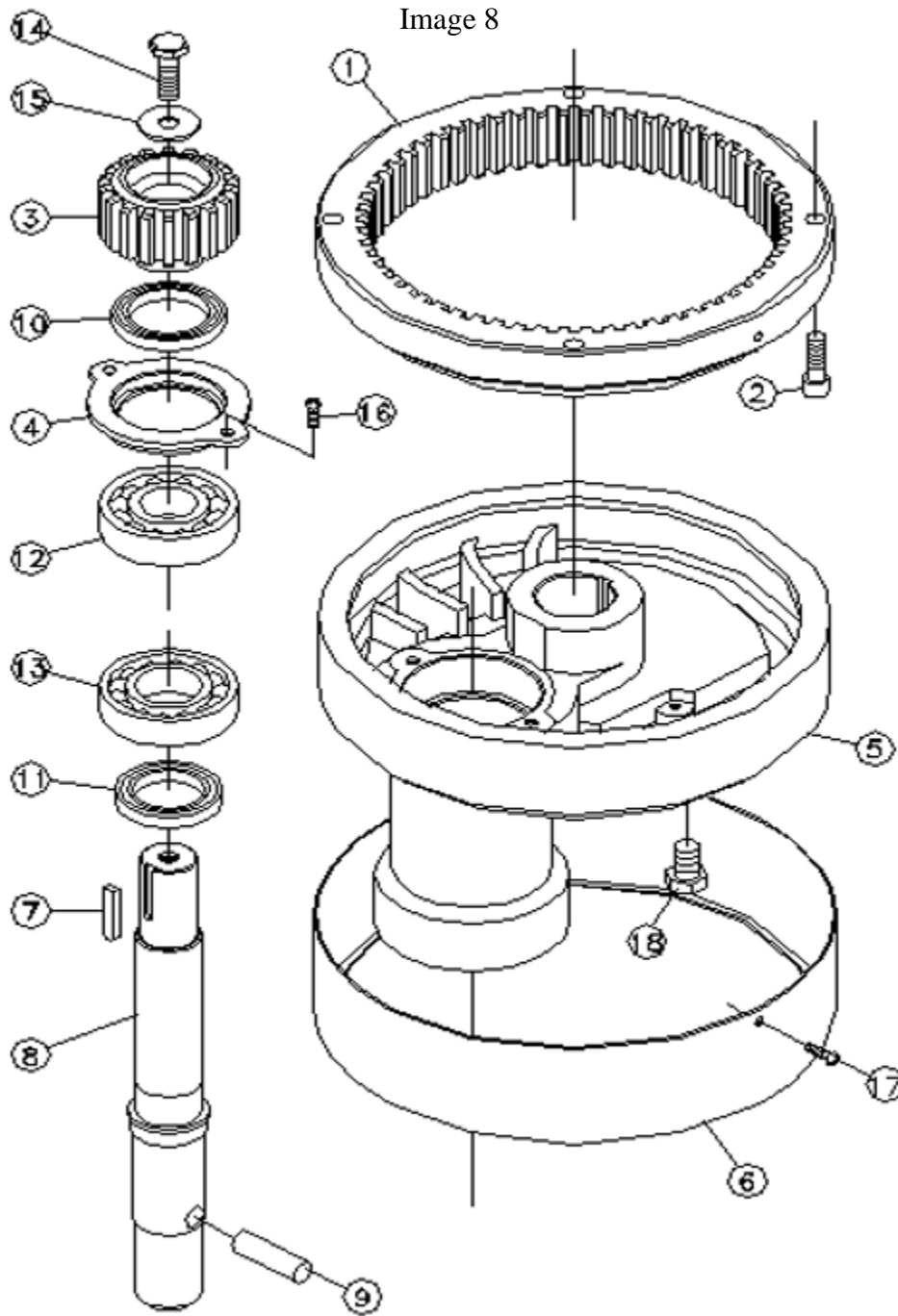

Image 8	Description or Name	Part No.	Qty
1	Internal Drive Gear	11091-08-001	1
2	Cap Screw 3/8" *1-1/4"	S-C-3/8*1-1/4	4
3	Internal Pinion (18 T)	11091-08-003	1
4	Retainer	11091-08-004	1
5	Planetary Head	11091-08-005	1
6	Head Ring	11091-08-006	1
7	Key 6" *6" *35	KR-6*6*35	1
8	Agitating Shaft	11091-08-008	1
9	Tapered Pin	11091-08-009	1

Image	Description	Part No.	Qty
10	Oil Seal TC43*58*07	OS-TC43*58*07	1
11	Oil Seal TC40*72*10	OS-TC40*72*10	1
12	Ball Bearing 6306Z	BR-6306Z	1
13	Ball Bearing 6207Z	BR-6207Z	1
14	Cap Screw 3/8" *1"	S-C-3/8*1	1
15	Flat Washer 3/8"	WB-3/8	1
16	Cap Screw 1/4" *5/8"	S-C-1/4*5/8	2
17	Mach Screw 3/16" *1/4"	S+R3/16*1/4	2
18	Bolt 1/2*3/4	S-1/2*3/4	1

Image 9

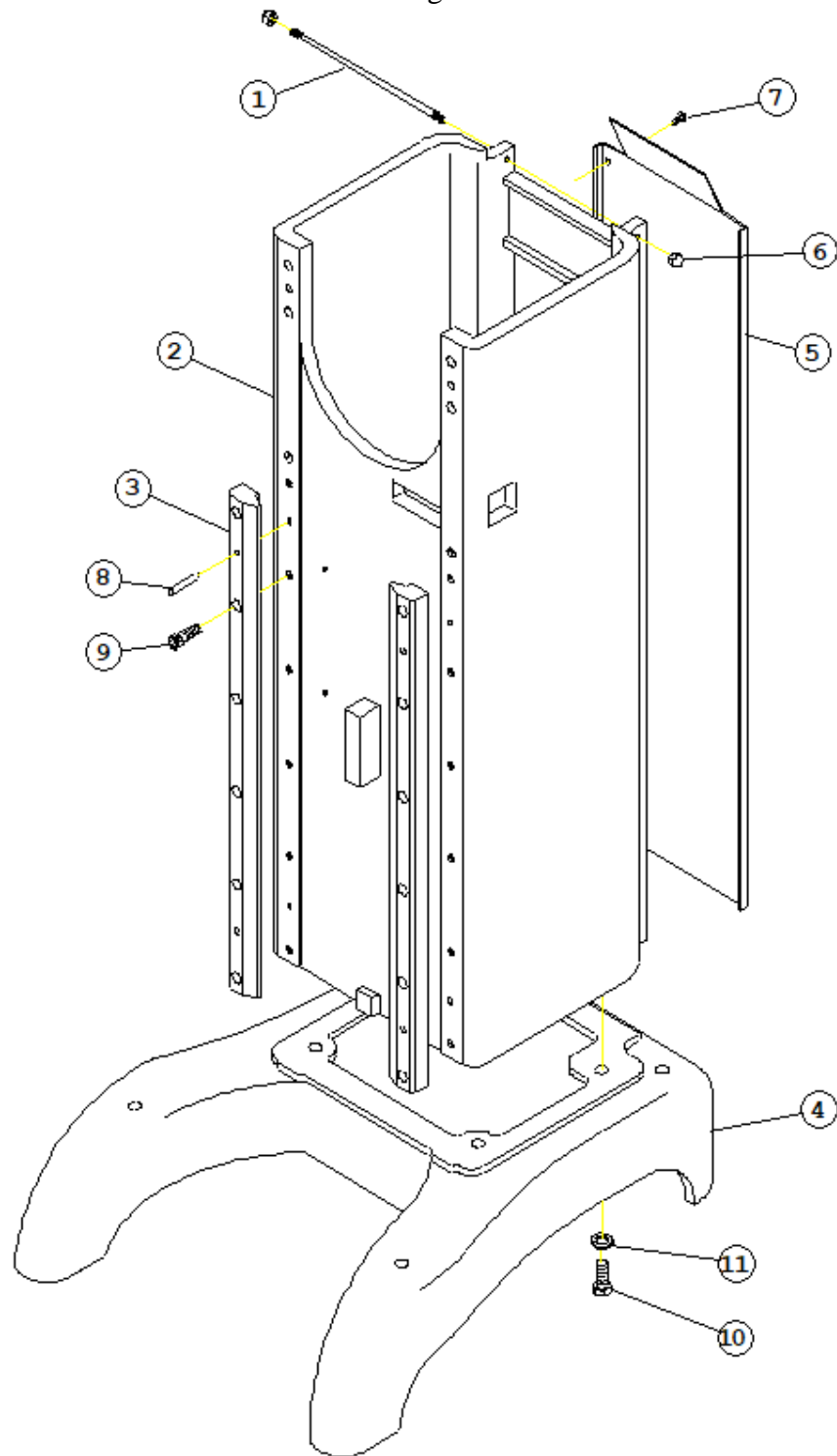

Image 9	Description or Name	Part No.	Qty
1	Fixed Top Cover	11091-09-001	1
2	Column	11091-09-002	1
3	Slideway	11091-09-003	2
4	Base	11091-09-004	1
5	Column Cover	11091-09-005	1
6	Nut 5/16" *18NC	NUT-5/16*18NC	2
7	Bolt 1/4"3/8"	S-1/4*3/8	8
8	Spring Pin 8*50L	SPP-8*50	4
9	Cap Screw 3/8"1-1/2"	S-C-3/8*1-1/2	12
10	Bolt 5/8" *3"	S-5/8*3	4
11	Spring Washer 5/8"	SW-5/8	4

Image 10

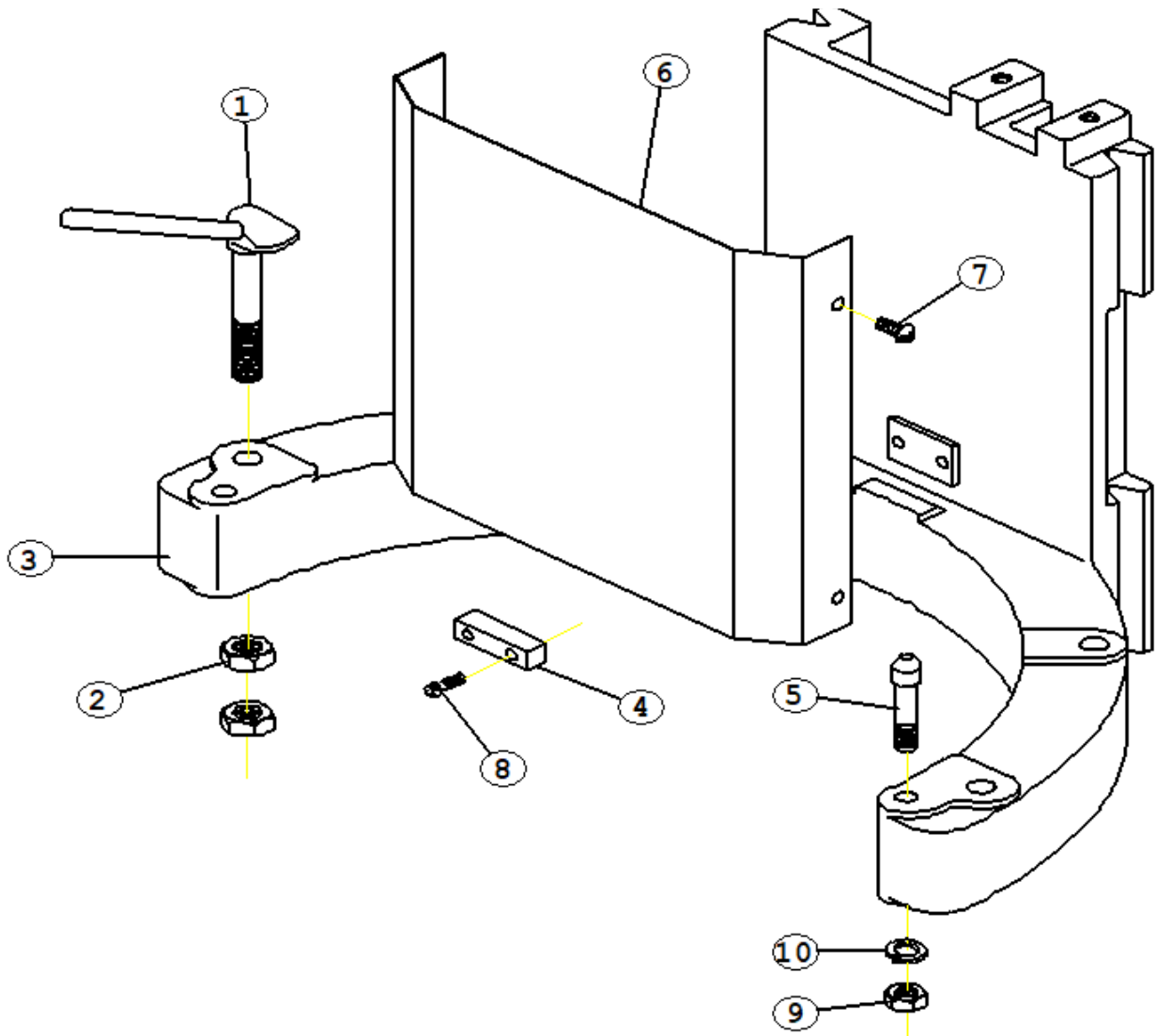

Image 10	Description or Name	HL Part No.	Qty
1	Bowl Clamp	11091-10-001	2
1	Screw	11091-10-001C	4
1	Screw	11091-10-001D	4
2	Nut W5/8" *11NC	NUT-5/8*11NC	4
3	Bowl Support	11091-10-003	1
3	Bowl Support(360Bowl)	11091-12-007C	1
4	Bowl Retainer	11091-10-004	1
5	Bowl Locating Pin	11091-10-005	1
6	Apron	11091-10-006	1
7	Mach Screw 3/16" *1/4"	S+R3/16*1/4	4
8	Cap Screw 1/4" *3/4"	S-C-1/4*3/4	2
9	Nut 1/2" *12NC	NUT-1/2*12NC	2
10	Washer 1/2"	W-1/2	2

Image 11

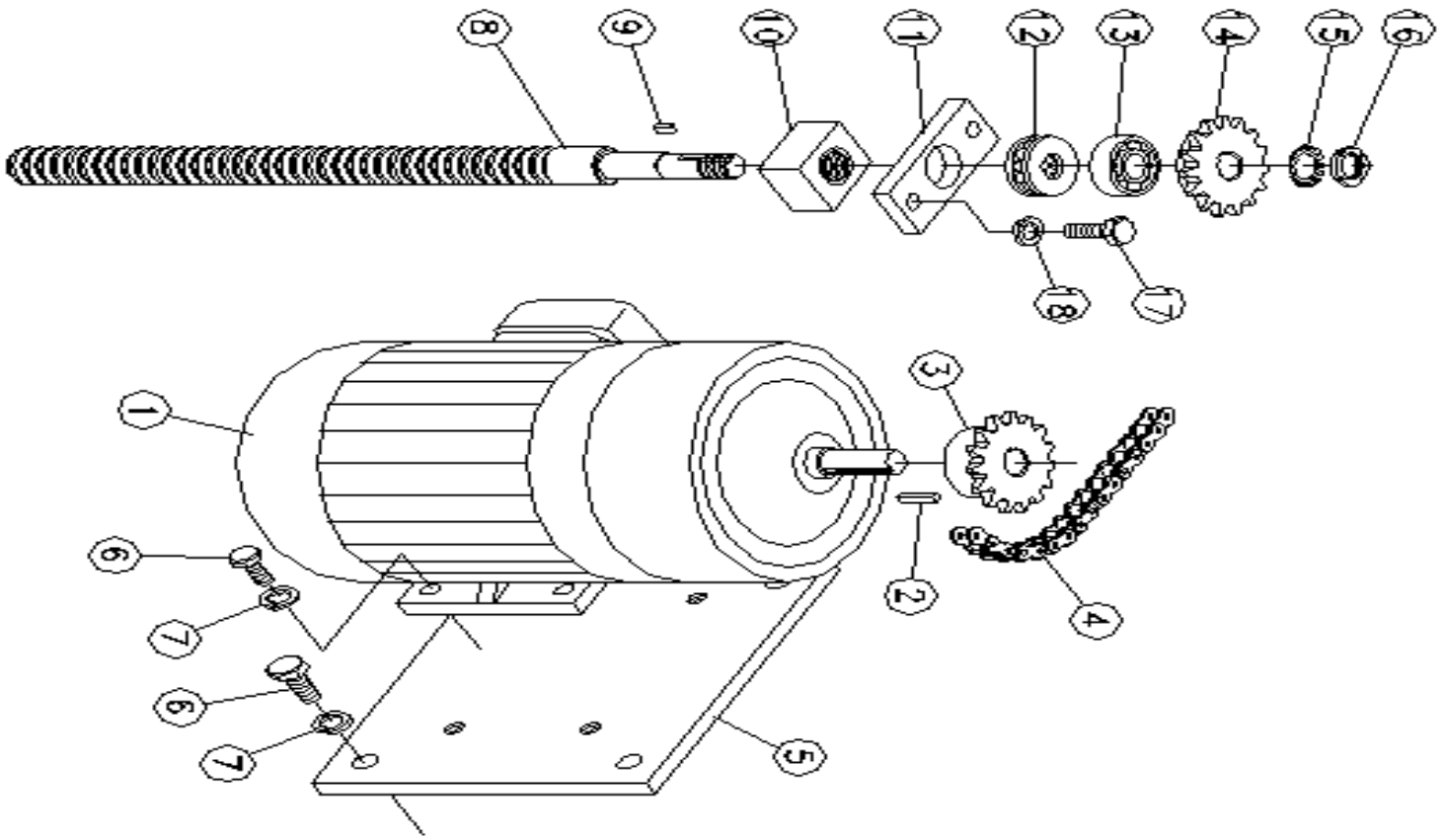

Image 11	Description or Name	Part No.	Qty
1	Reducer Motor	11091-11-001A	1
2	Key 7*7*25	KR-7*7*25	1
3	Chain gear	11091-11-016	1
4	Chain	BL-04-008	1
6	Bolt 5/16*1	S-5/16*1	8
7	Spring Washer 5/16	SW-5/16	8
8	Lifting Screw	11091-11-007	1
9	Key 5*5*13	KRR-5*5*13	1
10	Lifting Nut	11091-11-008	1
11	Retainer	11091-11-009	1
12	Ball Bearing #2903	BR-2903	1
13	Ball Bearing #6203Z	BR-6203Z	1
14	Chain gear	11091-11-017	4
15	Lock Washer Ø17	M17	1
16	Lock Nut M17	MN17	1
17	Bolt 3/8*1	S-3/8*1	2
18	Spring Washer 3/8	SW-3/8	2

Image 12

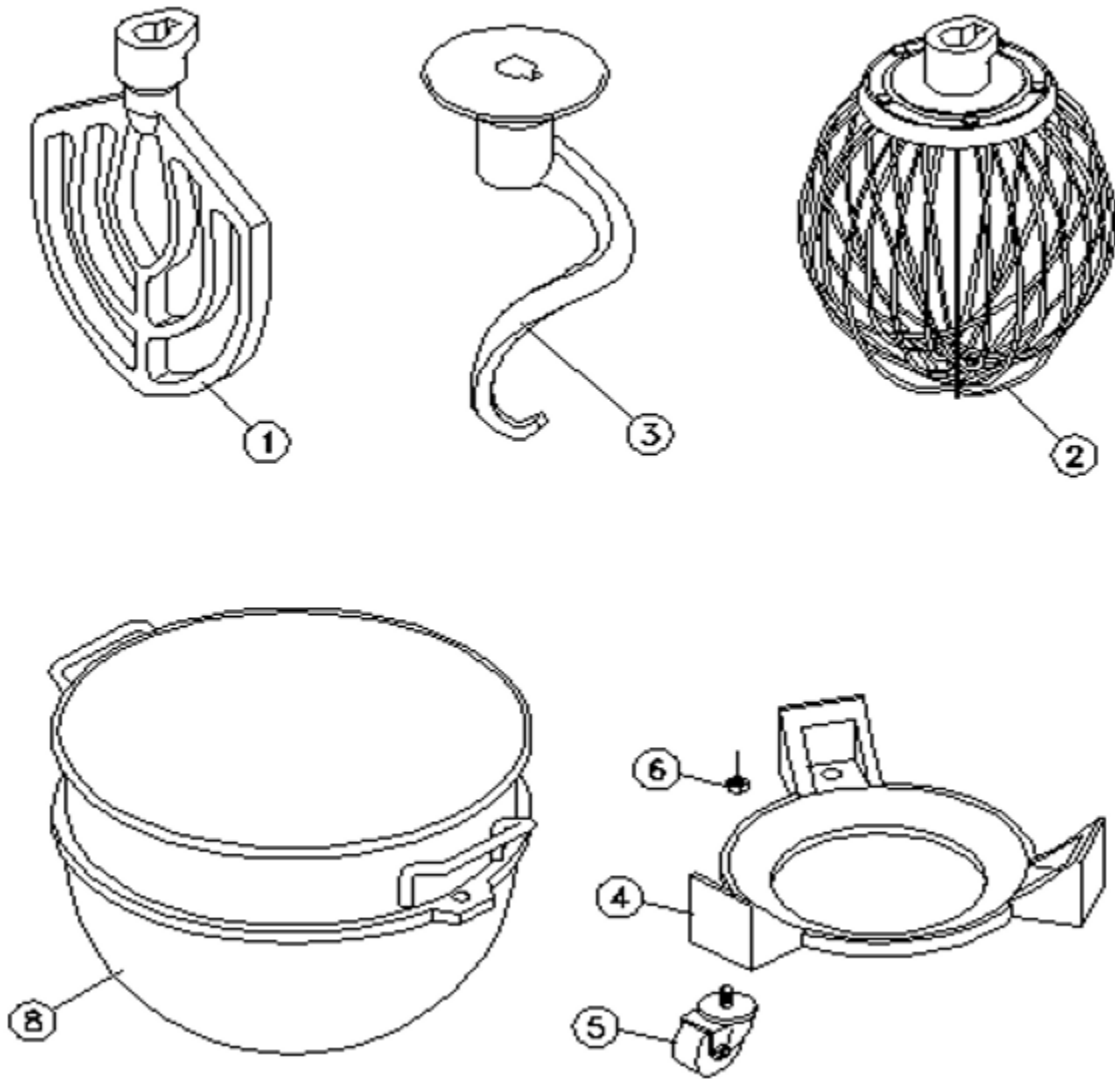

Image 12	Description or Name	Part No.	Qty
1	AL Flat Beater	11091-12-001	1
2	AL Wire Whip	11091-12-002	1
3	AL Dough Hook	11091-12-003	1
4	Trolley Base	11091-12-011	1
5	Wheel	WHEEL-001	3
6	Nut 1/2" *12NC	NUT-1/2*12NC	3
8	SS Bowl	11091-12-008	1

Image 13

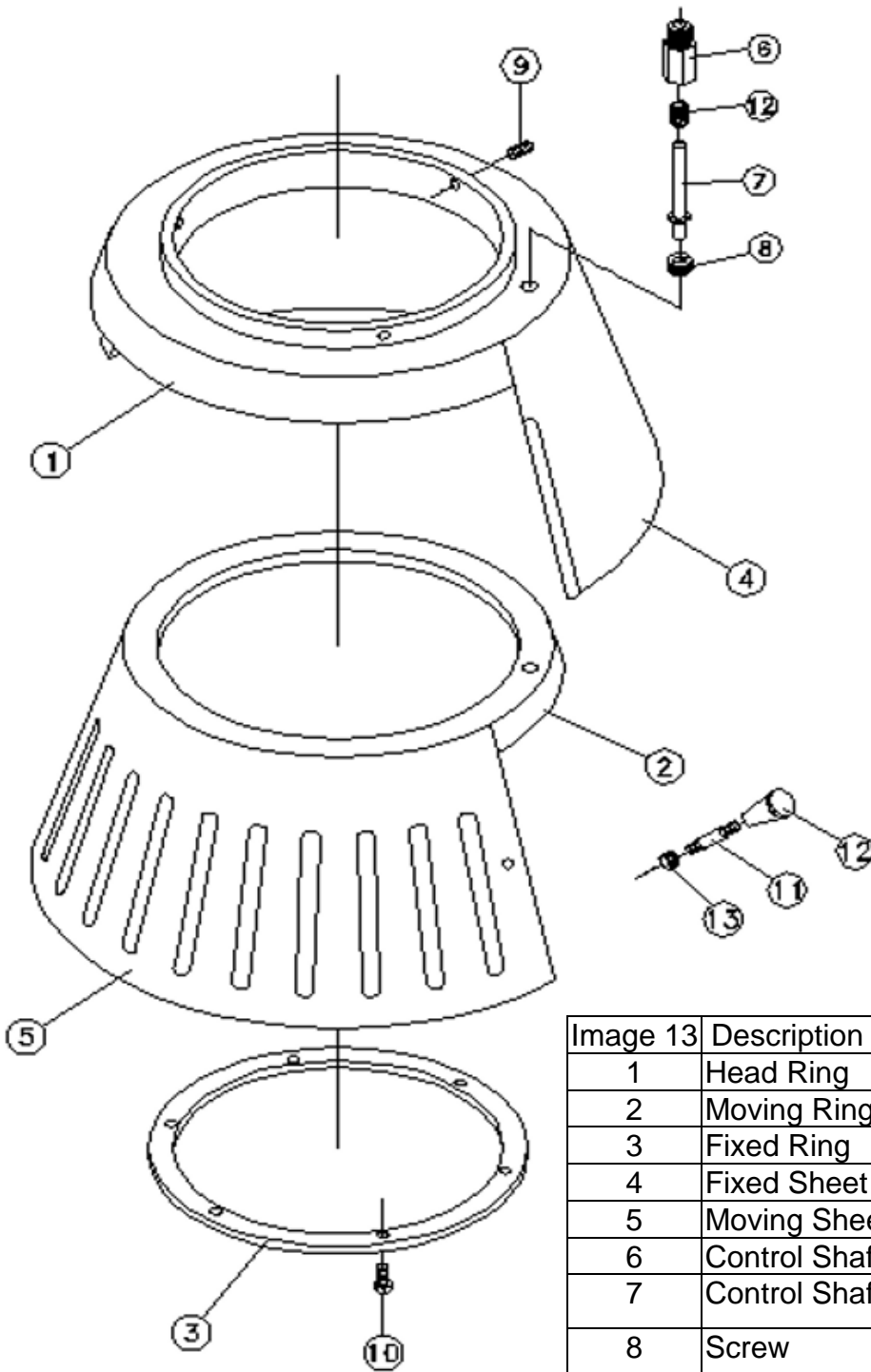

Image 13	Description or Name	Part No.	Qty
1	Head Ring	11091-13-001A	1
2	Moving Ring	11091-13-002A	1
3	Fixed Ring	11091-13-003A	1
4	Fixed Sheet	11091-13-004A	1
5	Moving Sheet	11091-13-005A	1
6	Control Shaft Seat	1109P-13-006	1
7	Control Shaf	11091-13-007	1
8	Screw	1109P-13-008	1
9	Set Screw 5/16" *3/8"	S-S5/16*3/8	3
10	Bolt 3/16" *1/2"	S-3/16*1/2	6
11	Handle	11012-07-002	1
12	Handle Knob	11012-07-001	1
13	Nut 5/16*18NC	5/16*18NC	1
14	Compression Spring	11091-13-012	1