

BMCBS01

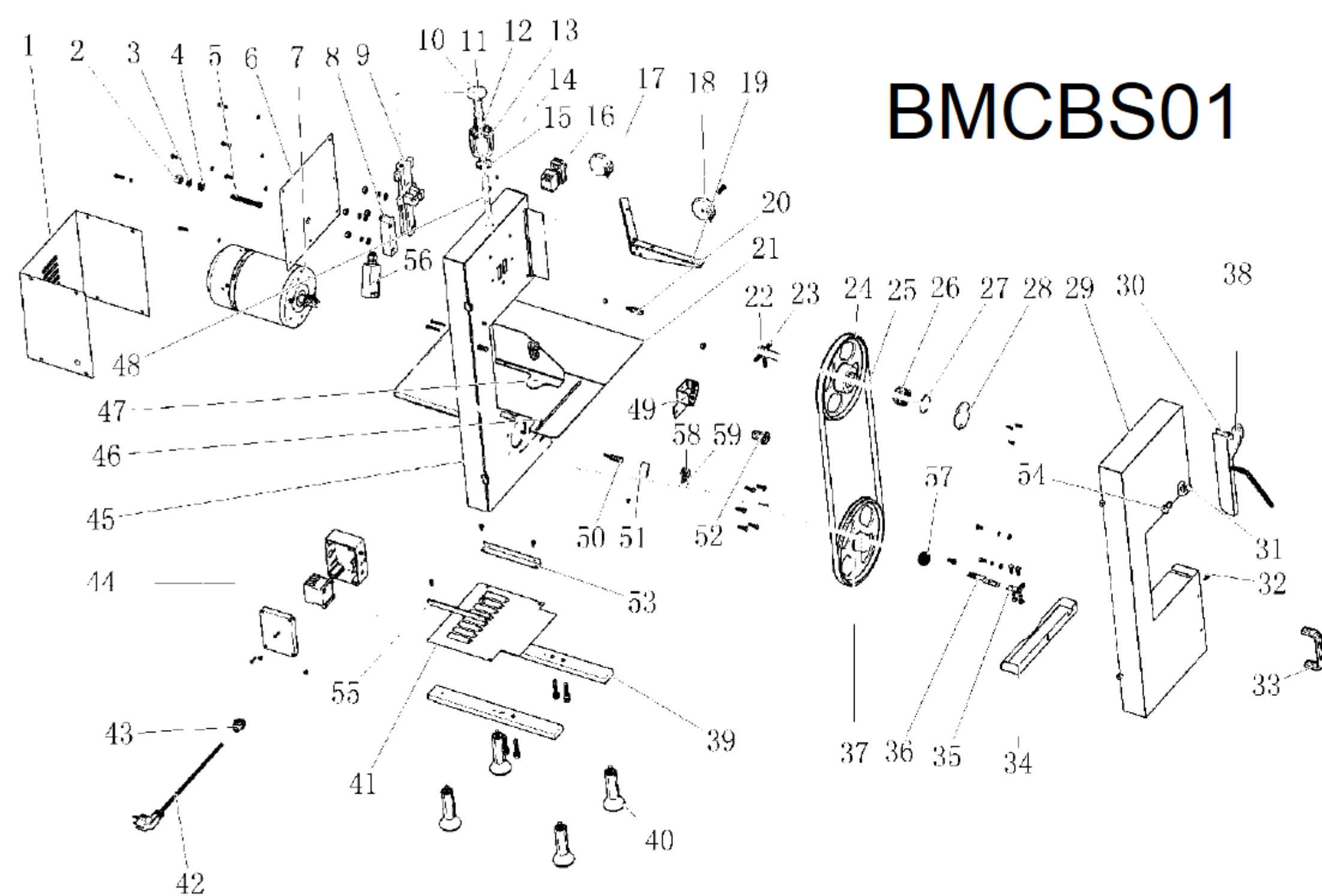

Part No.	Part Name	Part No.	Part Name
1	cover for motor	30	mouthpiece board
2	cap nut	31	shaft seat
3	flat gasket	32	screw
4	rubber gasket(jacket)	33	new knob
5	pole	34	case for roumo
6	back cover	35	surporting plate
7	motor	36	locking board for switch
8	guide plate	37	wheel
9	adjusting slider	38	mouthpiece board
10	top cover	39	backplane
11	locking nut	40	leg
12	spring	41	bottom
13	adjuing handle	42	wire and cord
14	steel ball	43	line card
15	end cover	44	electric box(include contactor)
16	switch	45	body
17	shaft ring	47	length plate
18	knob	48	axis for adjusting
19	channel iron	49	supporting for scraper
20	guide shaft	50	seat for scraper
21	table	51	scraper
22	axis	52	handle
23	small axis	53	angle iron
24	wheel	54	turning axis
25	saw	55	angle iron
26	bearing	56	microswitch
27	O ring	57	shaft collar
28	gland	58	stand for scraper
29	door	59	scraper