

Head Assembly & Parts Description

SHOWN:
36-Part Head
Assembly Drawing;
with 36, 18 & 9-Part
Description and
Part Numbers

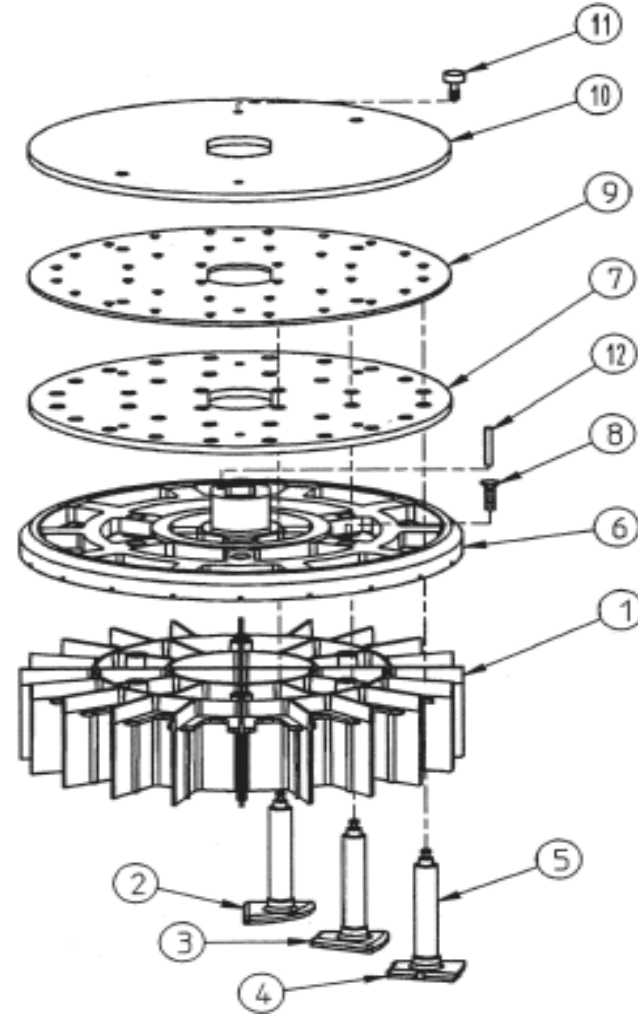

* 18 or 9-Part Heads (Not Shown)

LIST OF PARTS

Item	Qty.	Description	Part Number
1	1	36-Part Divisor	C4-141-0001
	1	*18-Part Divisor	* C4-141-0002
	1	* 9-Part Divisor	* C4-141-0046
2	4	36-Part Center Plug	A4-139-0001
	2	*18-Part Center Plug	* A4-139-0004
	1	* 9-Part Center Plug	* A4-139-0057
3	12	36-Part Intermediate Plug	A4-139-0002
	6	*18 Part Intermediate Plug	* A4-139-0005
	3	* 9 Part Intermediate Plug	* A4-139-0058
4	20	36-Part Outer Plug	A4-139-0003
	10	*18-Part Outer Plug	* A4-139-0006
	5	* 9 Part Outer Plug	* A4-139-0059
5	36	36 & 9-Part Plug Stem	B4-054-0003
	36	*18-Part Plug Stem	* B4-054-0001
6	1	36-Part Divisor Plate	C4-147-0008-P
	1	*18-Part Divisor Plate	* C4-147-0009-P
7	1	Plug Plate	C4-147-0002-P
8	6	Flat Head Phillips Screw	22-E-0407
9	1	Lock Plate	C4-147-0003
10	1	Cover Plate	C4-147-0004
11	2	Captured Screw	P4-927-0001
12	1	Pin	73-E-0620

Machine Parts Description w/o Head Assy.

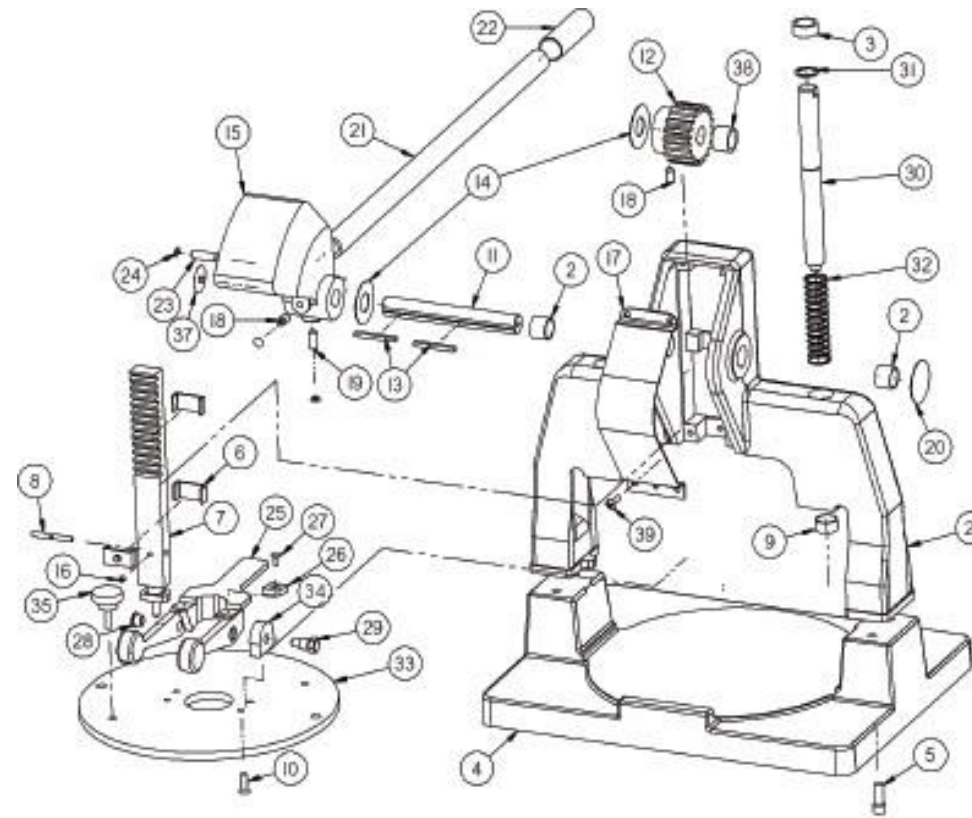

LIST OF PARTS

Item	Qty.	Description	Part Number	Item	Qty.	Description	Part Number
1	1	Yoke	C4-088-0001-P	20	1	Cover	A4-063-0002
2	2	Bushing	P4-909-0001	21	1	Handle	A4-092-0001
3	2	Bushing	P4-909-0003	22	1	Hand Grip	P4-939-0001
4	1	Base Cap	C4-030-0001-P	23	1	Socket Set Screw	29-Y-0610
5	4	Screw	12-E-0608	24	3	Set Screw Plug	A4-139-0007
6	3	Bushing Half	A4-024-0001	25	1	Trip Lever	B4-045-0004-P
7	1	Ram with Rack	B4-003-0003	26	2	Wear Plate	A4-147-0006-P
8	1	Ram Pin	A4-066-0001	27	2	Screw	22-E-0304
9	2	Bushing	P4-909-0002	28	2	Bushing	P4-909-0005
10	4	Screw	22-E-0407	29	2	Pivot Bolt	A4-033-0001
11	1	Gear Shaft	A4-053-0003	30	2	Spindle	A4-145-0001
12	1	Gear	A4-003-0002	31	2	Retaining Ring	P4-957-0001
13	2	Key	S-L-03-03-16	32	2	Spindle Spring	A4-082-0002
14	2	Spacer	A4-023-0002	33	1	Trip Plate	C4-147-0005-P
15	1	Lever w/Counterweight	B4-045-0001-P2	34	2	Pivot Tab	A4-146-0001-P
16	1	Slotted Set Screw	31-E-0402	35	2	Knob	P4-939-0002
17	1	Yoke Cover	B4-063-0119	36	1	Pan (Not Shown)	B4-149-0001
18	2	Socket Set Screw	29-Y-0605	37	1	Plug	A4-139-0024
19	1	Socket Set Screw	29-Y-0607	38	1	Bushing	P4-909-0031
				39	4	Yoke cover Screw	23-E-0406

BakeMax[®]

www.BakeMax.com

MODEL BMDMIH36/18/9

Manual Dough Divider

The BakeMax BMDMIH Dough Divider is simple to operate, and very accurate. The removable divider head assemblies can be cleaned daily, either by hand washing, or by placing into a dish or pan washer. Instructions for removal of the divider assembly are found inside this manual. Removal takes only seconds, and without the need for tools.

This Dough Divider will divide a single large piece of dough into either 36, 18 or 9 equal pieces, the weight of each piece being determined by the weight of the large piece placed into the pan initially, and the head assembly being utilized.

DOUGH DIVIDING PROCEDURE

A simple formula for determining the size of the initial piece of dough is to decide what each piece of dough should weigh. Multiply this weight by 36, 18 or 9 depending on head assembly, then divide by 16 (ounces), and you will have the weight (in pounds) of the initial piece of dough needed to be placed into the pan.

Example: Each piece needs to weigh 2 ounces.

$$2 \text{ ounces} \times 36 \text{ (pieces)} = 72 \text{ ounces}$$

$$72 \text{ (ounces)} \div 16 \text{ (ounces)} = 4 \text{ lbs. 8-ounces.}$$

(See Dough Weight Chart on back for additional examples)

OPERATING INSTRUCTIONS

Step 1: Place the large dough piece to be divided into a lightly dusted Pan then place the Pan into the Machine. **Note:** Before placing the Pan into the Machine, press the dough by hand so it completely covers the bottom of the Pan.

Step 2: After placing the Pan into the Machine, pull down on the Handle and exert a firm pressure for 3-4 seconds to uniformly flatten the dough inside the Pan.

Step 3: Slightly relax the pressure on the Operating Handle and push down on the Trip Lever to release the Cutting Knives from the Head Assembly. Next, push the Operating Handle all the way down, and the Knives will cut the dough into evenly divided pieces.

Raise the Operating Handle to the start position, remove the Pan and dump out the divided dough pieces. You are ready to repeat the procedure.

Tip: For sticky dough products, line the bottom of the Pan with a circular piece of parchment paper. The paper can be used repeatedly.

STEP



STEP



STEP



DOUGH SCALING EXAMPLES

36 Divisions		18 Divisions		9 Divisions	
Weight of dough piece to be placed into Pan for dividing	Equals 36 pieces each weighing	Weight of dough piece to be placed into Pan for dividing	Equals 18 pieces each weighing	Weight of dough piece to be placed into Pan for dividing	Equals 9 pieces each weighing
2 lbs. 4 oz. (1008 gr)	- 1 oz. (28 gr)	2 lbs. 4 oz. (1008 gr)	- 2 oz. (56 gr)	2 lbs. 4 oz. (1008 gr)	- 4 oz. (113 gr)
2 lbs., 13 oz. (1260 gr)	- 1-1/4 oz. (35 gr)	2 lbs., 13 oz. (1260 gr)	- 2-1/2 oz. (71 gr)	2 lbs., 13 oz. (1260 gr)	- 5 oz. (142 gr)
3 lbs., 6 oz. (1512 gr)	- 1-1/2 oz. (42 gr)	3 lbs., 6 oz. (1512 gr)	- 3 oz. (85 gr)	3 lbs., 6 oz. (1512 gr)	- 6 oz. (170 gr)
3 lbs., 15 oz. (1764 gr)	- 1-3/4 oz. (49 gr)	3 lbs., 15 oz. (1764 gr)	- 3-1/2 oz. (99 gr)	3 lbs., 15 oz. (1764 gr)	- 7 oz. (198 gr)
4 lbs., 8 oz. (2016 gr)	- 2 oz. (56 gr)	4 lbs., 8 oz. (2016 gr)	- 4 oz. (113 gr)	4 lbs., 8 oz. (2016 gr)	- 8 oz. (227 gr)
5 lbs., 1 oz. (2268 gr)	- 2-1/4 oz. (63 gr)	5 lbs., 1 oz. (2268 gr)	- 4-1/2 oz. (127 gr)	5 lbs., 1 oz. (2268 gr)	- 9 oz. (255 gr)
5 lbs., 10 oz. (2520 gr)	- 2-1/2 oz. (70 gr)	5 lbs., 10 oz. (2520 gr)	- 5 oz. (141 gr)	5 lbs., 10 oz. (2520 gr)	- 10 oz. (283 gr)
6 lbs., 3 oz. (2772 gr)	- 2-3/4 oz. (78 gr)	6 lbs., 3 oz. (2772 gr)	- 5-1/2 oz. (156 gr)	6 lbs., 3 oz. (2772 gr)	- 11 oz. (312 gr)
6 lbs., 12 oz. (3024 gr)	- 3 oz. (85 gr)	6 lbs., 12 oz. (3024 gr)	- 6 oz. (170 gr)	6 lbs., 12 oz. (3024 gr)	- 12 oz. (340 gr)
7 lbs., 5 oz. (3276 gr)	- 3-1/4 oz. (92 gr)	7 lbs., 5 oz. (3276 gr)	- 6-1/2 oz. (184 gr)	7 lbs., 5 oz. (3276 gr)	- 13 oz. (368 gr)
7 lbs., 14 oz. (3528 gr)	- 3-1/2 oz. (99 gr)	7 lbs., 14 oz. (3528 gr)	- 7 oz. (198 gr)	7 lbs., 14 oz. (3528 gr)	- 14 oz. (397 gr)
8 lbs., 7 oz. (3780 gr)	- 3-3/4 oz. (106 gr)	8 lbs., 7 oz. (3780 gr)	- 7-1/2 oz. (212 gr)	8 lbs., 7 oz. (3780 gr)	- 15 oz. (425 gr)
9 lbs. (4032 gr)	- 4 oz. (113 gr)	9 lbs. (4032 gr)	- 8 oz. (226 gr)	9 lbs. (4032 gr)	- 16 oz. (453 gr)

Dough weights may increase or decrease according to dough viscosity, bench rest time and formulation

Interchangeable/Removable Head Assemblies - No Tools Required!

SPECIFICATIONS

Models DX-BMIH-36, DX-BMIH-18, DX-BMIH-9

Cuts.....	9, 18 or 36 Pieces
Range.....	36-part (1 oz up to 4 oz (28 gr to 113 gr) 18-part (2 oz up to 9 oz (56 gr to 255 gr) 9-part (4 oz up to 17oz (113 gr to 482 gr)
Machine Dimensions	14"D x 18-1/2" W x 21-1/4" H
Boxed Dimensions	15-3/4"D x 19-1/2" W x 25-1/2"H
Machine Weight (with one head).....	80.5 Lbs. (36.5 kg)
Machine Shipping Weight (with one head).....	89 Lbs. (40.4 kg)
Machine Shipping Weight (with two heads).....	104 Lbs. (47.2 kg)
Machine Shipping Weight (with three heads).....	120 Lbs. (54.4 kg)

Unit comes equipped with one Stainless Steel Pan.
Additional Pans and Portable Stand are available.

Additional Pans . . . Part # DX-B4-149-0001 ~ Portable Stand . . . Part # DX-B4-436-0072

----- HEAD ASSEMBLY REMOVAL AND DISASSEMBLY PROCEDURES -----



Figure 1: Remove pan, completely loosen both Black Knobs. **Do not Drop** the Divider Head as damage may occur!



Figure 2: Push downward on the Trip Lever and hold while pulling the handle down which will separate the Head Assembly from the Trip Plate.



Figure 3: While holding the Handle down with one hand, use your other hand to rotate the Head Assembly 1/4 turn until the Head Assembly releases.



Figure 4: Return the Handle to the upper position and remove Head Assembly for cleaning or interchange with Optional Head Assembly.



Figure 5: If you wish to disassemble completely, place the Head Assembly into the Pan, loosen both Black Knobs and lift off Cover Plate.



Figure 6: Slide the Locking Plate in the direction to allow Stems to move to the opposite end of the Slots and remove the Locking Plate.



Figure 7: Now lift the Plug Plate, exposing the Stems.



Figure 8: The Divider Assembly may now be removed but need not be disassembled further.



Figure 9: To disassemble the Divider from the Divider Plate, remove the six screws and separate these parts.



Figure 10: Plugs with Stems are shown when the Divider (fig. 8) is removed. Notice the three different circles of Plugs and the pattern they are in.

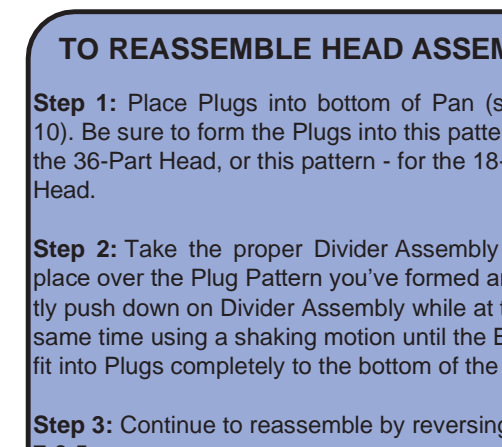

TO REASSEMBLE HEAD ASSEMBLY

Step 1: Place Plugs into bottom of Pan (see fig. 10). Be sure to form the Plugs into this pattern + for the 36-Part Head, or this pattern - for the 18-Part Head.

Step 2: Take the proper Divider Assembly and place over the Plug Pattern you've formed and gently push down on Divider Assembly while at the same time using a shaking motion until the Blades fit into Plugs completely to the bottom of the Pan.

Step 3: Continue to reassemble by reversing steps 7-6-5.

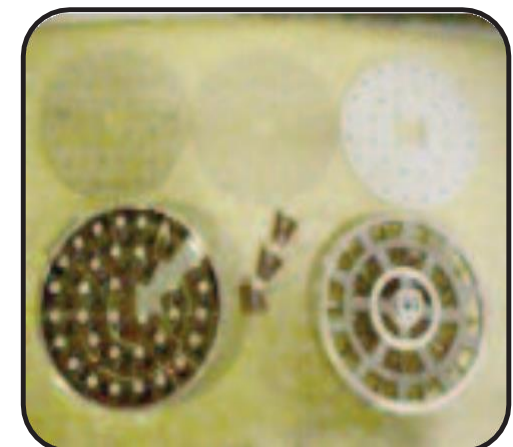

Top L to R: Cover Plate, Locking Plate, Plug Plate
Bottom L to R: Pan, Plugs, Divider & Divider Plate