

OPERATOR'S MANUAL

DXM-SS

Single Heat Manual Dough Press

doughXpress



For Customer Service:
Call 1-800-835-0606 or Visit hixcorp.com

HIX CORPORATION



CONTENTS

<i>Receiving & Setup</i>	3
<i>Power</i>	4
<i>User Adjustable Settings</i>	5
<i>Machine Presets</i>	6
<i>Pressing Dough</i>	7-8
<i>Handle Bracket Position</i>	9
<i>Interchangeable Platens</i>	10
<i>Facts & Questions</i>	11
<i>Troubleshooting</i>	12
<i>Cleaning & Maintenance</i>	13
<i>Parts List</i>	14-15
<i>Warranty</i>	16

BEFORE warranty repair you MUST get Prior Authorization



Intertek

RECEIVING & SETUP

PLATEN SURFACE

Slight surface imperfections are a normal part of the aluminum casting process for the platens on your press. These are not considered a defect and do not affect the functionality of the machine in any way.

SHIPPING OR RETURNS

NOTE *Save all of your shipping/packing material. Do not risk costly shipping damage, ship only in original box.*

1. Fasten machine to plywood shipping base with bolts provided.
2. Tie or tape handle securely to base.
3. Place in original box, and put side liner and top liner in place. Fold flaps and seal the box. (Additional bottom boards, box and liners may be obtained from your supplier for a normal cost.)

UNPACKING

Remember to save all packing material - including box, liner and board. You may need these for shipping your machine or if a repair is necessary in the future.

INSPECTION

Inspect your machine for hidden shipping damage. Contact the delivery company immediately, should you find damage.

INSTALLATION

1. Lift press from skid and place on cart, if you purchased one with the press. Align legs with holes on top of cart and bolts (supplied) fasten to cart. You will need a 9/16 wrench.

CAUTION: Heavy lifting can cause injury. We recommend two person lifting or use of a mechanical aid when handling this press. Remember to always maintain natural curves of back and bend knees to lift.

2. Plug the cord of the press into a correctly grounded electrical outlet. The correct voltage is indicated on the identification tag of the press.

NOTE: Upon receiving your new equipment, some debris or residue may be present on the aluminum platen(s). Clean the platens per the instructions provided prior to first use.

3. Remove wrap from handle and platens

WARNING: Do not use an extension cord to supply power to your press.

This machine is designed in accordance with the NSF-8 sanitations standard to be sealed to the countertop to prevent the harborage of vermin and the accumulation of dirt and debris. To comply with this standard the end customer must seal around the perimeter of the base of the machine to the countertop with a food grade RTV silicone sealant that is certified to the NSF/ANSI 51 standard such as Dow Corning #732 Multipurpose Sealant.

POWER

TURNING THE POWER “ON”

1. Once the machine is plugged into power, the display will show a “Red Icon” as shown below. To turn the power on to the machine, simply press the Red Icon.



2. The display will then come on and look similar to what is shown below.

To turn the Power “OFF” to the machine, simply press the Green “Power” Icon in the upper right corner of the display and the machine will turn “OFF.”



To adjust the temperature or time settings, simply press the “UP” or “DOWN” arrows to change the values.

As the temperature is warming up from a cold start, the temperature digits will be RED when the heat platen temperature is more than 10 degrees away from desired set point temperature.

When the platen temperature is less than 10 degrees, but more than 5 degrees from the desired set point the temperature displayed will be YELLOW.

When the platen temperature displayed is within 5 degrees of the desired set point, the temperature digits will be GREEN.

When the actual platen temperature reaches the set point, the controller will BEEP.

3. A little “Red Dot” shown above in the lower left corner of the temperature display window represents the “Heat Light.” This indicator will be on when the controller is applying power to the heating element. It is normal for this indicator to flash on and off as heat is required.

USER ADJUSTABLE SETTINGS

USER ADJUSTABLE SETTINGS

Pressing the “GEAR” Icon  in the upper left corner of the Home Screen will switch the screen to the user settings menu, shown below.

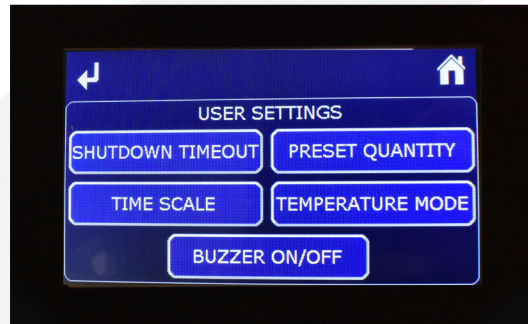

Pressing the “Back Arrow” Icon in the upper left corner of the display will take you to the previous screen.

Pressing the “Home” Icon in the upper right corner of the display will take you to the “HOME” Screen.

Pressing any of the USER SETTINGS buttons will take you to one of the screens shown below where you can adjust the machine settings to your preferences.



Once you have made the desired adjustments, press the “Back Arrow” or “Home” Icon.

Any changes in any of the settings or values you have made will be automatically stored as you leave that screen.

MACHINE PRESETS

PRESETS FOR TIME & TEMPERATURE SETTINGS

The controller has several Time and Temperature Preset options (No Presets, Two Presets, Four Presets, Toggle Two Presets) which are selectable in the “User Adjustable Settings” as outlined on the previous page.

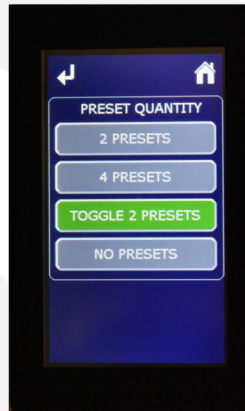

ON THE HOME SCREEN

If one of the buttons is “GREEN” then that button is the ACTIVE time and temperature preset on the controller. See below:

2 presets option



4 presets option



If you wish to make an adjustment to the time or temperature, simply press the UP/DOWN arrows next to the Time or Temperature values to change the number to the new setting desired.

NOTE: You will notice when you change either the Time or the Temperature away from the preset values, all the preset buttons will turn “Gray.”

To store the new Time or Temperature value(s) in a preset button location, simply press and HOLD on the desired preset button for 2 seconds. Once the new values are stored, the button will turn GREEN and the controller will BEEP to acknowledge the new values are stored.

To “recall” a preset, simply touch on the desired preset button and the Time and Temperature setting stored in that location will be recalled and displayed in the Time and Temperature values.

PRESSING DOUGH

PRESSING DOUGH

Your dough press is designed for easy use and operation to reliably press dough balls. Thickness, shape, and size are directly related to your dough ball, its shape, the temperature of the dough, the recipe of your dough, the type of lubricating food oil, as well as the settings of your machine. You should experiment with the following for the results you want.

CAUTION: Excessive pressure can cause structural damage, voiding the machine warranty!

1. Touch the power button located on the front of the control panel.
2. Set the desired temperature on the time/temperature control panel as instructed in this manual. Generally 110°-130°F for room temperature dough and 140°-150°F when using refrigerated dough. When the actual platen temperature reaches the set point, the controller will BEEP.

WARNING: Never attempt to press frozen dough. Personal injury and damage to your machine could result!

NOTE: This symbol represents “Hot Surfaces”



3. With the press in the open position, adjust the press to the desired thickness by turning the thickness control knob located at the top of the press. Thickness is reduced by turning the knob clockwise. Thickness is increased by turning it counterclockwise.



NOTE: The numerical thickness setting are for reference only and have no specific value to the thickness of a pressed or finished product.

NOTE: Adjustments may be required from one product to another and will vary to achieve the desired result.

WARNING: Make all adjustments while press is open. Adjusting the thickness while under pressure will result in damage to the press.

Thickness knob



PRESSING DOUGH

4. Lightly lubricate the lower platen with olive oil, food/cooking oil or other food release lubricant when pressing pizza dough. Place corn tortilla dough balls between sheets of parchment paper.

TIP: Dough balls at room temperature give you the best results.

5. Place your dough ball in the center of the lower platen and add a small amount of your food lubricant to the top of the dough ball. **Do not add flour or dust with flour.**
6. Pull down the handle all the way, applying pressure, until it stops.
7. After the designated time has elapsed (generally, 3-10 seconds for room temperature dough) raise the handle all the way up to the open position.

CAUTION: Excessive pressure can cause structural damage, voiding the machine warranty!

8. Remove your flattened dough and place on a screen or pan with the top side face down. You are now ready for final shaping, edging, and toppings. Tortillas can be moved to a tortilla warmer or skillet for finishing.
9. Move on/off switch to “OFF” when finished using the press for the day. This will turn the power off to the entire machine.

DOUGH BALL WEIGHTS

<i>Pizza Crust Size</i>	<i>Weight of the Dough Ball</i>	<i>Tortilla Crust Size</i>	<i>Weight of the Dough Ball</i>
6"	5-8 oz.	6"	1-1.5 oz.
8"	6-10 oz.	8"	1.5-2.5 oz.
10"	8-12 oz.	10"	2.5-3.25 oz.
12"	16-18 oz.	12"	3.25-3.75 oz.
14"	18-20 oz.	14"	4-4.5 oz.
16"	20-22 oz.	16"	4.5-5 oz.
18"	22-24 oz.	---	-----

DOUGH SHRINKAGE

Ways of Overcoming this Problem:

1. **Recipe** - What is the percentage of water content in the dough? What is the percentage of oil content in the dough?
2. **Mixing** - Mixing procedure, such as water temperature and mixing speed.
3. **Dough Preparation** - What is the time between mixing and pressing? How is the dough being stored?
4. **Pressing** - What is the temperature of the dough when pressing? What is the temperature of the press when pressing? How long is the dough being pressed?

HANDLE BRACKET POSITION

The handle bracket will be in shipping position when received. In order to use the handle bracket to swing the lower platen receiver, you will need to position the handle bracket for use.

1. Remove (1) bolt and lock washer completely.

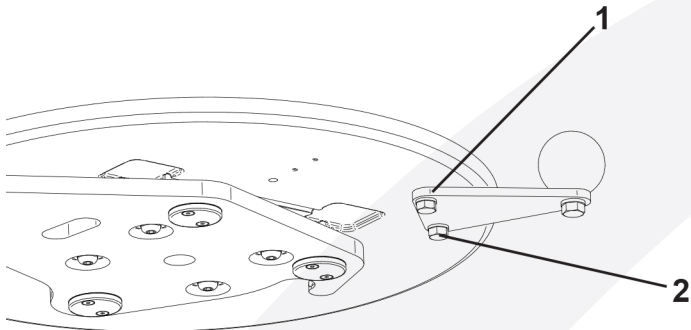

2. Loosen (2) bolt only enough to allow the bracket to pivot.



3. Slide the handle bracket to the left, so that the holes line up. Replace (2) bolt and lock washer and tighten.

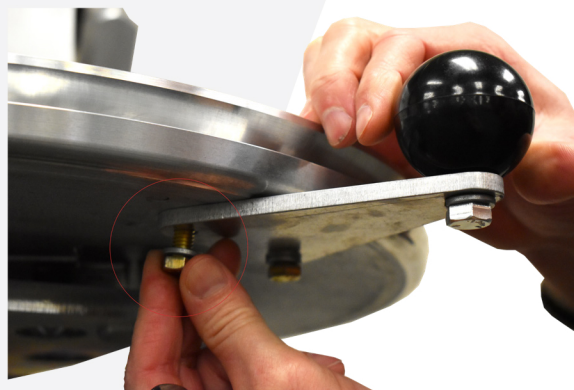

INTERCHANGEABLE PLATENS

1. Remove the 18" flat platen that came with the press by rotating lower platen counterclockwise and then lifting up. If you purchased the DXP-PR Platen Rack, place the unused platen on one of the tiers.



2. Place the different sized platen on the press by lining up the bolts with the holes on the press.

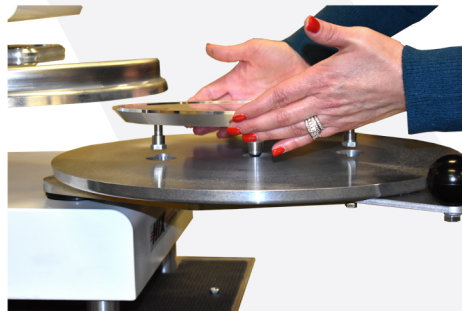

3. Once the platen is set on top of the lower platen receiver, you will turn the platen clockwise until you hear and feel the "click" of the spring clips (you will need to use a bit of force to do so).



FAQs

PIZZA DOUGH

Q: Why won't my dough press to size?

- Weight of the dough ball - not enough dough
- Temperature of the dough ball might be cold - higher temp/longer press time
 - Set to thick - change thickness setting

Q: When I press my dough it gets sticky? Why?

- Very wet dough - turn up temperature
- Platens are not clean - possible flour build up

Q: Why won't my dough press out even?

- Unlevel platens

Q: Why is my dough tearing when I press?

- Usually this is caused by under mixing the dough in the mixer - mix on slow speed for a minimum of 10 minutes
 - Cold or frozen particles in the dough

Q: What temperature should I be pressing the dough?

- Cold dough could vary from 130°F to 170°F
- Warm dough or room temperature dough 100°-110°F

Q: How long should I be pressing the dough?

- Warm dough 2-7 seconds
- Cold dough 5-10 seconds

Q: Will the heat kill the yeast?

- NO - yeast dies at 180°F for 2-minutes - The temperature we are pressing could range from 100°-170°F for a maximum pressing time of 10 seconds. This will not affect the yeast in the dough.

Q: Is 18" the only size crust I can get with this press?

- No - The weight of the dough ball and your thick & thin setting will determine the size of your crust. Different dough ball weights will determine the size of your crust.

Q: How do I get an edge with the press?

- Press out dough normally - (2) ways you can get an edge...
 - a. After pressing crust, form edge by hand
 - b. When saucing crust leave a 1/4" to 1/2" ring from the edge to let your oven bake the edge naturally for a nice handmade look.

TORTILLA DOUGH

Q: Why won't my dough press to size?

- Weight of the dough ball - not enough dough
 - Set to thick - change thickness setting
 - Dirty or unclean platens

Q: Why won't my dough press out even?

- Dough ball placement
 - Unlevel platens

Q: Why is my dough coming apart when I press it?

- Pressing too long with too much heat
 - Not enough oil on dough ball
 - Build up on platens

Q: What temperature should I be pressing at?

- 275° - 325°F

Q: How long should I be pressing the dough?

- 2 -3 seconds

Q: Can I press corn tortillas?

- Yes - but you need to use either parchment or baking paper...
 - a. Place paper down on the platen
 - b. Place dough ball(s) on paper
 - c. Place another sheet of paper on top of dough ball(s)
 - d. Press

Q: Can I cook the tortillas on the press?

- Yes - cooking the tortillas on the press can be done in the following manner
 - a. Set press temperature 275° - 325°
 - b. Press dough ball(s) 2-3 second press
 - c. Lift handle and leave tortillas on lower platen for 1 - 1:30 min.
 - d. Turn tortillas over and leave on lower platen for 1 - 1:30 min. on second side.
 - e. Remove

NOTE: For faster production and a better finished product, it is recommend to use a two step process using a tortilla press and tortilla warmer.

TROUBLESHOOTING

TIMER WON'T COUNT DOWN

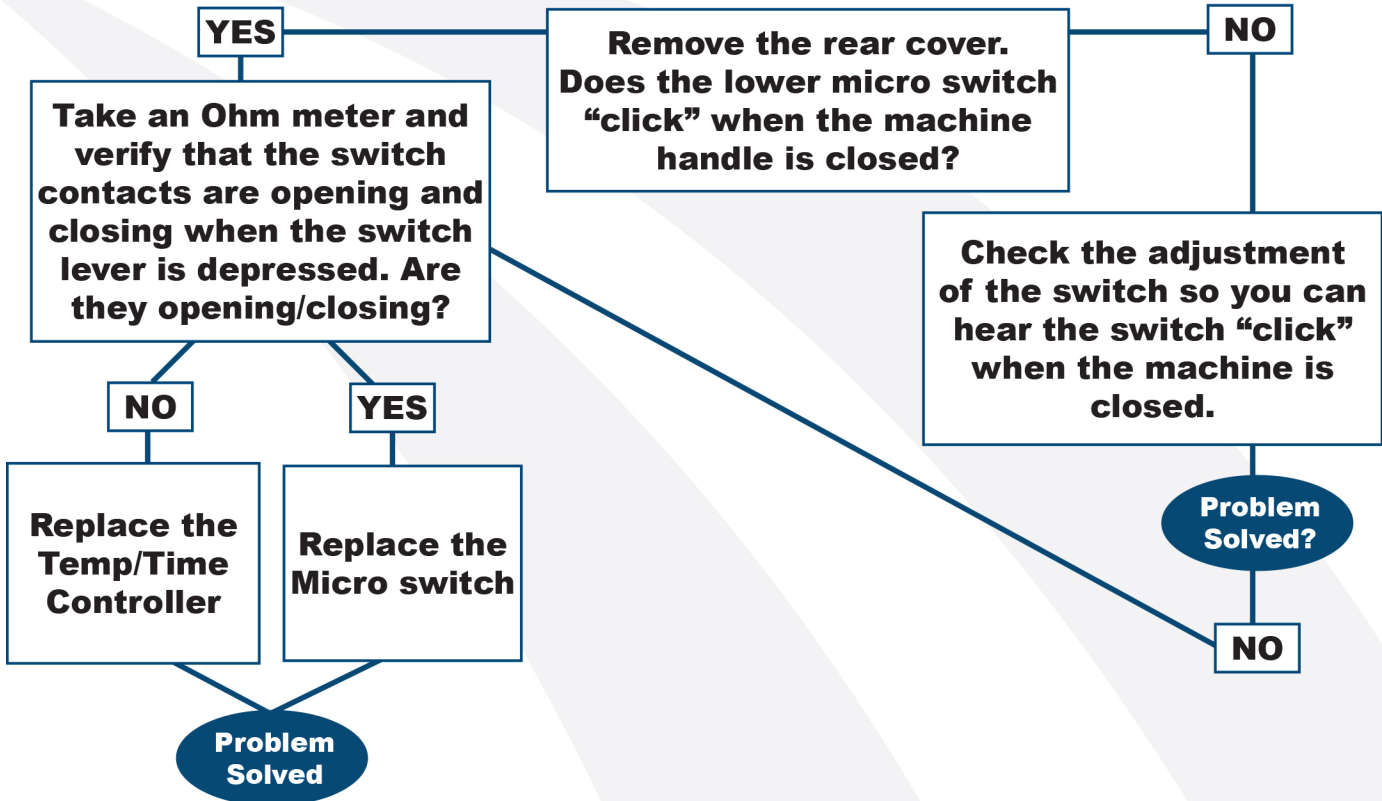

PRESS IS NOT PRESSING DOUGH ENOUGH

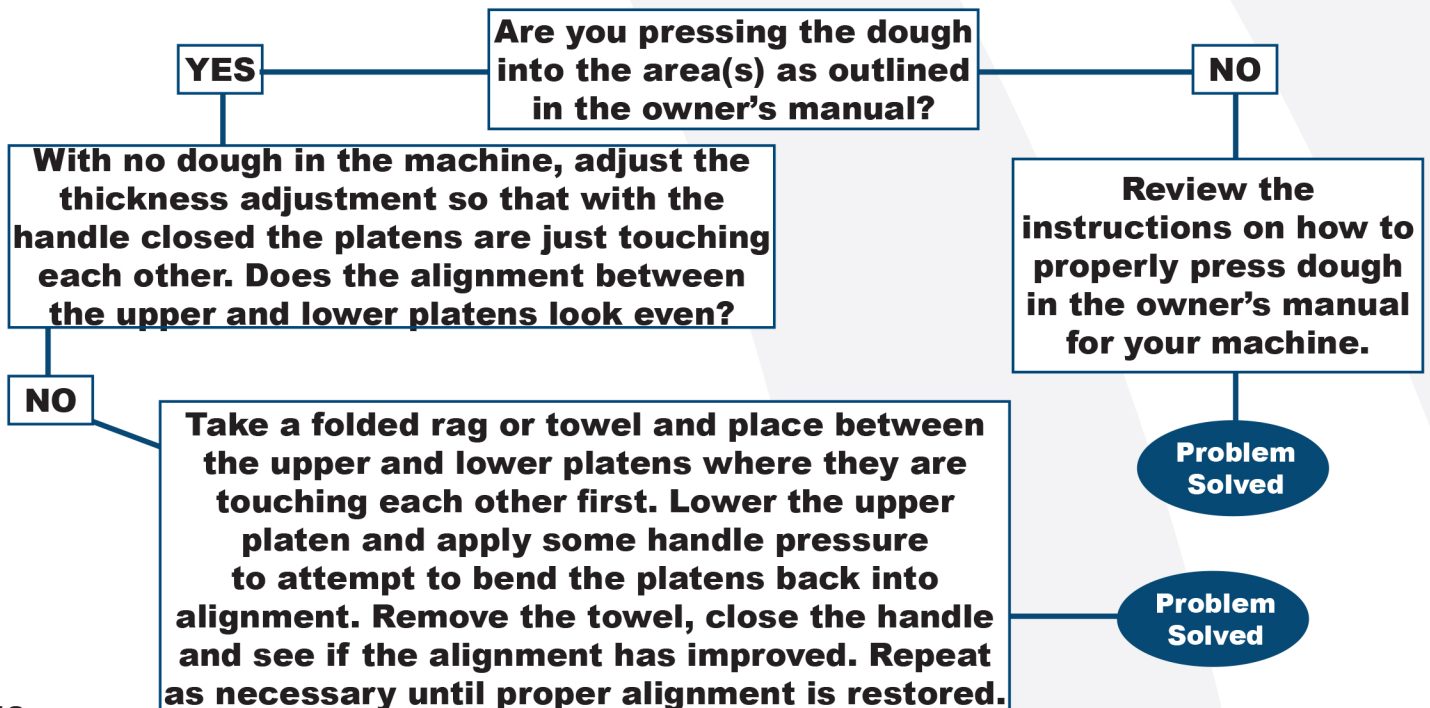

CLEANING & MAINTENANCE

WARNING: Before cleaning, performing maintenance or repairs make sure the machine is turned off and the machine is unplugged.

*****This appliance is not waterproof. Never spray or pour water or any other cleaning solution onto this appliance.*****

CLEANING ALUMINUM UNCOATED HEAT PLATEN(S)

1. Unplug the machine and allow it to cool.
2. Open the heat platen for easier access.
3. Dampen a nonmetallic scrubbing sponge with a mild soap or detergent to remove any excess material from the heat platen(s).
4. Wipe clean with a dry cloth.

CLEANING PTFE (XYLON) COATED PLATEN(S) (OPTIONAL FEATURE)

1. Unplug the machine and allow it to cool.
2. Open the heat platen for easier access.
3. Clean the PTFE coated platen with a mild soap and warm water applied with a soft cloth or sponge. Do not use steel wool, scrub sponges, kitchen or oven cleaners or any other kind of abrasive material. This will damage the coating.
4. Wipe clean and dry with a cloth.

CLEANING OUTSIDE SURFACES OF THE MACHINE

Use a mild soap and warm water applied with a soft cloth or sponge. Do not use steel wool, scrub sponges, kitchen or oven cleaners or other abrasives that will damage the painted surface.

LUBRICATION

Your press requires lubrication every 15,000 cycles or every 6 months. Use NSF/NLGI2 rated food grade grease (such as Bel-Rey No-Tox #2 or equivalent). Lubrigate all moving or hinged points.

CIRCUIT BREAKER RESETTING

Should the circuit breaker trip, simply allow the machine to cool for 2 minutes and then reset the circuit breaker by pressing the button back in to allow the machine to come back on. If the circuit breaker continues to trip, have an electrician diagnose the cause of the fault.



REPLACEMENT PARTS LIST (DXM/DXM-SS MODELS)

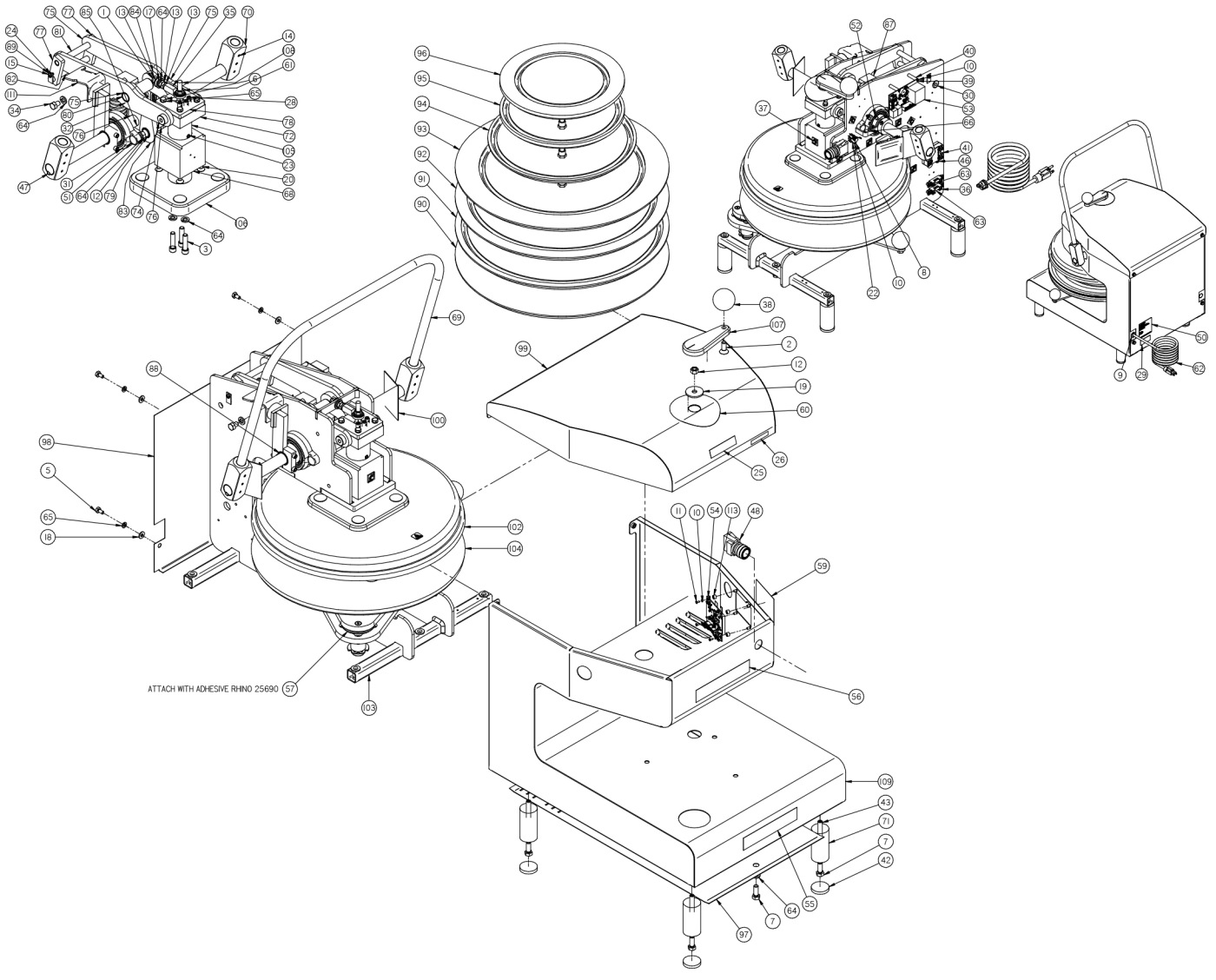

109	8621159	DP LOWER ENC MAN 1 SWITCH SS LV
110*	8621174	DX SERIES PACKAGING
111	8621237	HANDLE STOP, DX SHEETMETAL
112	90134	SCREW CPSKT 1/4-20x0.750
113	9044419	NYLON STANDOFF FOR EMERSON

REPLACEMENT PARTS LIST

(DXM/DXM-SS MODELS)

ITEM#	PART#	TITLE	ITEM#	PART#	TITLE
1	10024	SCREW SET 3/8-24 X 2.000	55	71003	M-DECAL HIX CORPORATION
2	10027	SCREW FHSKT 3/8-16X1.000 SS	56	71011	M-DECAL DOUGHXPRESS
3	10341	SCREW CPSKT 3/8-16X1.500 GD 8	57	71041	SEAL SHAFT 2.500
4*	10458	WIRE CUT LIST DXM	58*	71088	CONTROL TEMP HTC 18" 14COND
5	10660	BOLT 1/4-20X0.500	59	71089	DECAL TEMP / TIME HTC
6	10678	BOLT 1/4-20x0.750	60	71092	DECAL THICKNESS DIAL CLEAR/BLK
7	10850	BOLT 3/8-16 X 1.000	61	73247	NUT 3/8-16 JAM NYLON INSERT ZPS
8	13103	SCREW MCH 4-40x0.750 RHSL	62	74609	CORDSET 120v 16/3 SJOW 5-15P
9	13250	CORD GRIP HEYCO 1557 RDD201	63	76752	FUSE MDA-10/TCA 10A
10	13919	WASHER LOCK HEL SPR #4 ZP	64	79418	WASHER LOCK HEL SPR 3/8 ZP
11	14524	SCREW MCH 4-40X0.250 PHPH	65	79426	WASHER LOCK HEL SPR 1/4 ZP
12	14571	NUT 3/8-16 ZPS	66	8600420	M-DXM LIMIT SWITCH WELDMENT
13	14647	NUT HEX JAM 3/8-16 NC ZP	67	8600450	DXM STOP BAR WELDMENT
14	15131	SCREW SET 1/4-20x0.250	68	8600920	DP JACK SHAFT HOUSING ASSY
15	15321	SCREW MCH 10-32x0.375 PHPH	69	8601075	DXM STAINLESS HANDLE
16*	15644	SLEEVING SZ 3 #710C-3BK	70	8601081	M-DP DXM HANDLE ADAPTOR
17	16683	WASHER FLT .375x0.875x.078 ZPS	71	8601083	M-DP LEG 3"
18	16774	WASHER FLT .281 X 0.625 X .063 ZPS	72	8601217	M-DXE ADJSMNT SCREW RETAINER
19	25720	WASHER FLT .406X1.500X.120 ZPS	73*	8601219	M-DXE JACK ADJ STOP
20	28142	SCREW FHSKT 5/16-18x1.000	74	8601220	M-DXE DRIVE PIN
21	31453	FOOT RUBBER 0.75x1.50x0.25	75	8603101	DXE LINK STABILIZER
22	31823	SWITCH MICRO SMALL SEMI-HOOK	76	8603103	M- LINK CRANK LARGE
23	32224	SCREW SET 3/8-16x0.375 DP	77	8603105	M-DXE LINK FOLLOW
24	32228	WASHER LOCK HEL SPR #10 ZP	78	8603110	DXE ADJUSTMENT SCREW CAP
25	32239	M-DECAL DXM SS	79	8603115	PIN CRANK LARGE
26	32241	DECAL POWER	80	8603116	M- PIN ROD LARGE
27*	33020	MANUAL OWNERS DXM	81	8603117	DXE PIN STABILIZER
28	33071	DETENT 3/8-16X0.188 BALL	82	8603118	DXE PIN FOLLOWER
29	33605	DECAL, UNPLUG MACHINE	83	8603124	LINK MAIN LARGE 1/32 CHAMFER LEFT
30	39446	GROMMET .313IDx.563 GRV	84	8603128	LINK MAIN LARGE 1/32 CHAMFER RIGHT
31	39586	BEARING 1-1/4" 2 BOLT FLANGE	85	8603132	M-DXM PINION SHAFT
32	39705	SPRING DIE M150-500	86*	8603133	DXM SPRING HOLDER
33*	39748	KEY STL .250x.250x1.75 UNDSZ	87	8603134	SPRING PLATE UPPER
34	50342	BOLT 3/8-16x0.500	88	8603502	DXE MAIN SHAFT BUSHING
35	61220	ROD END 3/8-24 RH FEM	89	8603503	M-DXE PIN RETAINER
36	61638	FUSE HOLDER S8301-1 BUSSMANN	90	8607051	ASSY., LOWER PLATEN REMOVEABLE 18 INCH
37	62448	WIRE CABLE CLIP ADHESIVE BACK	91	8607052	ASSY., LOWER PLATEN REMOVEABLE 17 INCH
38	62561	KNOB PHENOLIC CL 852-PB	92	8607053	ASSY., LOWER PLATEN REMOVEABLE 16 INCH
39	62707	SCREW MCH 4-40x1.750 PHPH SS	93	8607054	ASSY., LOWER PLATEN REMOVEABLE 14 INCH
40	62723	SPACER .140X.313X1.25 NYLON	94	8607055	ASSY., LOWER PLATEN REMOVEABLE 12 INCH
41	62731	RELAY SS 25A 3-32VDC INPUT	95	8607056	ASSY., LOWER PLATEN REMOVEABLE 10 INCH
42	63711	FOOT RUBBER 1-1/2"ODx1/4"	96	8607057	ASSY., LOWER PLATEN REMOVEABLE 8 INCH
43	63746	SCREW SET 3/8-16x1.750	97	8609047	DXE-DXM BOTTOM COVER
44*	63916	KEY STL .250x.250x.750	98	8609064	DP ENC BACK PANEL SS
45	65242	SCREW CPSKT 1/4-20x1.750	99	8609067	O-DP ENC UPPER ENCLOSURE SS
46	66729	SCREW MCH 10-32x0.375 GRND	100	8609081	M-DXM SHAFT SEAL
47	67490	KEY STL .250x.250x1.50 UNDSZ	101	8609117	DXM SHAFT CLAMP
48	68136	SWITCH PB YEL 1NO 120V LATCH	102	8620122	ASSY. UPPER PLATEN 120V LV
49*	70077	SCREW FHSKT 1/4-20x1.000	103	8620171	ASSY FRAME WITH SUPPORTS
50	70268	DECAL HIX I.D. 3" X 3" SILVER	104	8620323	ASSY. DP LOWER PLATEN RECEIVER NO HEAT
51	70563	BOLT CAR 3/8-16x1.250	105	8621026	JACK SHAFT D-TXM-2-18
52	70597	SCREW SET 5/16-24x0.625 CP	106	8621100	P-ASSY UPPER PLATEN MOUNT PLATE
53	70956	CONTROL TEMP EM TOUCH-SPLIT	107	8621111	M-HANDLE LC
54	70956	CONTROL TEMP EM TOUCH-SPLIT	108	8621153	M-DX JACK .5 HEX SHAFT

WARRANTY

BEFORE warranty repair you MUST get Prior Authorization: Call 1-800-835-0606 Warranty will be voided otherwise.

doughXpress® will automatically register the equipment on the date it was shipped to you or your distributor. If the equipment was not purchased directly from HIX, but through a distributor (either domestic or foreign), please keep a copy of their sales invoice showing the serial number and date it was sold/shipped to you with this warranty.

In this case, we will use the distributor's invoice date as the beginning warranty date. **STAPLE A COPY OF YOUR RECEIPT TO THIS WARRANTY** and keep in a safe place to provide verification of your warranty should a problem occur. Thank you.

Please fill in the following information and attach a copy of your receipt for your records.

Date Purchased: _____ **From:** _____

Model #: _____ **Serial #:** _____

This warranty applies to equipment manufactured by the HIX Corporation (HIX), Pittsburg, Kansas, U.S.A. HIX warrants to the original purchaser, the full line of doughXpress® product against defects in workmanship and material, except for wear and tear for a period of one year parts and labor limited warranty on most items, there are selected items which may carry a two year warranty (refer to owners manual.) All dough press carts, compressors, and accessories are warranted for 90 days from the date of purchase. Repairs include parts and labor only, excluding is the following:

1. Overtime Labor Rates
2. Expedited Freight for Parts
3. doughXpress® assumes no responsibility for down time or loss of product. All defective parts must be returned to doughXpress® for credit. Repairs must be pre-authorized by doughXpress® prior to work commencing.
4. Travel time is not covered by doughXpress®, unless pre-authorized by doughXpress®. In the event of a defect, doughXpress®, at its option, will repair, replace or substitute the defective item at no cost during this period subject to the limitations of insurance and shipping costs stated below.

This warranty does not cover normal wear and tear, damages due to accident, misuse/abuse, alterations or damage due to neglect, or lack of proper lubrication or maintenance. doughXpress® shall not be responsible for repairs or alterations made by any person without the prior written authorization by doughXpress®. This warranty is the sole and exclusive warranty of doughXpress® and no person, agent, distributor, or dealer of doughXpress® is authorized to change, amend or modify the terms set forth herein, in whole or in part.

In the case of a problem with the equipment identified herein, doughXpress® should be contacted during regular business hours to discuss the problem and verify an existing warranty. doughXpress® personnel will assist the customer to correct any problems which can be corrected through operation or maintenance instructions, simple mechanical adjustments, or replacement of parts. In the event the problem cannot be corrected by phone, and upon the issuance of a return authorization by doughXpress®, the equipment shall be returned to doughXpress® or an authorized service representative. All insurance, packaging and shipment/freight costs are solely the responsibility of the customer, and doughXpress® shall not be responsible for improper handling or damage in transit.

doughXpress® customer service personnel may be contacted for complete return authorization and reconditioning information. This expressed warranty is given in lieu of any and all other warranties, whether expressed or implied, including but not limited to those of merchantability and fitness for a particular purpose, and constitutes the only warranty made by doughXpress®. In no event shall doughXpress® liability for breach of warranty extend beyond the obligation to repair or replace the nonconforming goods. doughXpress® shall not be liable for any other damages, either incidental or consequential, or the action as brought in contract, negligence or otherwise.

This warranty gives you specific legal rights and you may also have other rights which vary from state to state.



1201 E. 27th Terrace • Pittsburg, KS 66762 • U.S.A.

Phone: (800) 835-0606 • Fax: 620-231-1598

Web site: hixcorp.com • E-Mail: sales@hixcorp.com