

BakeMax BMPM60B 60 Quart Belt Driven Mixer



Questions? OEM Parts?

Contact Us:

Toll Free: 1-800-565-2253

Email: Info@BakeMax.com

www.BakeMax.com



WARNING: PLEASE READ AND FOLLOW THE INSTRUCTIONS BELOW BEFORE OPERATING PRODUCT

- When using the machine, please confirm that you have read all the instructions within this manual.
- Beware of any child/children or any other persons who are near the machine before operating.
- Do not put hand near moving parts.
- Remove all obstacles, which may interfere with machine functions.
- Keep work area clean and clear of clutter.
- Do not sit or stand on machine
- Do not wear loose cloth or jewellery when operating machine as it may get caught in moving parts and cause injury
- When the machine is abnormal or broken, you should stop using and check it or have it checked by a professional.
- Disconnect from power source before performing maintenance on the machine.
- When machine is not in use, please clean and store properly.
- Do not place any electrical parts or plug/cord in water.
- The cord should be away from the heat.
- Don't hang out the cord on the desk or cabinet.
- Machine may have sharp or pointed edges, use caution when cleaning.
- This machine should only be operated by personnel who can read, understand and respect warnings and instructions regarding this machine and the manual.
- Keep this manual in a safe place for further and regular reference and ordering parts.
- Please write model serial and date of purchase of your machine in the space provided in case you will need to order parts in the future.
- Always work by security code of your country, state, province, city or committee of your work place.

Installation, Operation and Care of Model BMPM60B

+ SAVE THESE INSTRUCTIONS +

GENERAL

The HL-11091 Planetary Mixer is an advanced design, highly reliable professional food processing tool, and is ideal for mixing all types of dough, as well as eggs, cream, mayonnaise, etc.

There is 3 speeds and various style attachments which can be selected to obtain the best using food are made of alloy aluminum or they're with hygiene standard.

This model Mixers are equipped with powerful 2 HP motors and strong belt drive design.

If your operation and maintenance are correct, then it will give you years of service, and obtain the best using result.

INSTALLATION

UNPACKING

Immediately before unpacking the mixer, check it for possible shipping damage. If you find the packaging material or the machine is damaged before unpacking, contact the carrier within 3 days of delivery.

Prior to installation, test the electrical service to assure it agree with the specifications on the machine data plate located on the backside of the pedestal.

INSTALLATION DIAGRAM (inch)

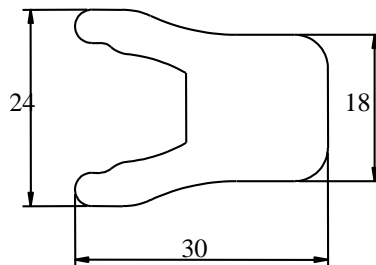
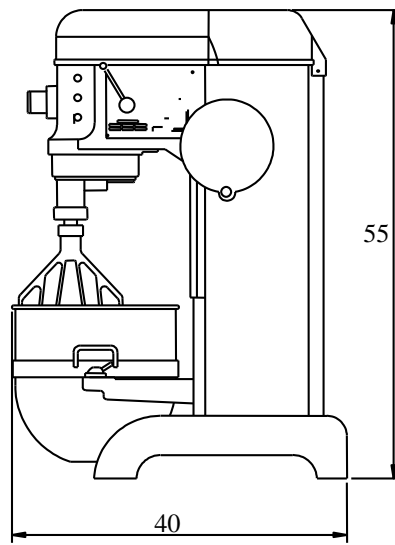
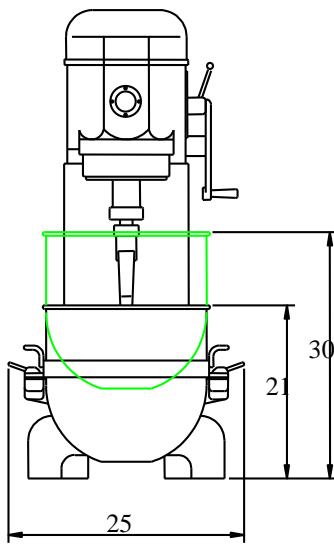

LOCATION

Place the Mixer in a convenient location and allow working space on the handwheel or power bowl lift switch side. All maintenance can be handled from this side, the top and the front. Set the mixer level and use shims if the floor is uneven, the machined edge on the top of the transmission case makes an excellent surface for leveling.

ELECTRICAL CONNECTIONS (Cord Connected Mixers)

- Before making the electrical connections, read the specifications on the nameplate to make sure that they agree with those of your electric service.
- Electrical connections should be made by qualified workmen, who will observe all applicable Safety Codes and the National Electrical Code.
- Be sure the planetary runs in the direction shown by the arrow in the planetary head. Reverse direction is forbidden.
- To start the motor, push the ON button. The speed selector handle must be at one of the numbers indicating a speed, not at an intermediate position.

A 3 PHASE MIXER SHOULD CHECK MIXING ROTATION WHEN ELECTRICAL CONNECTED.

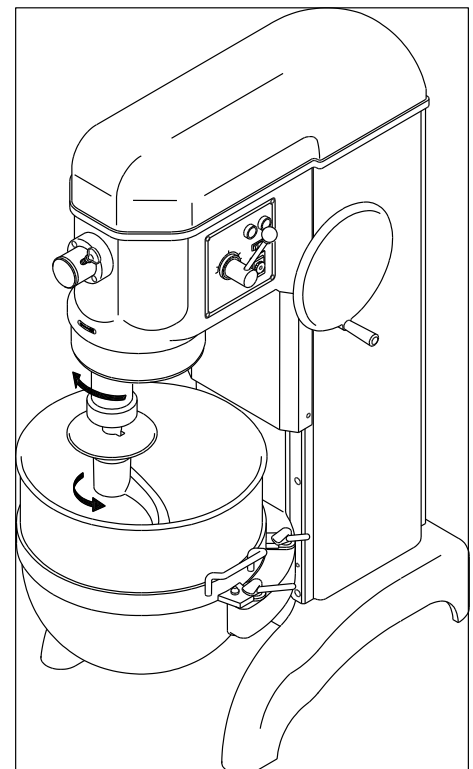

WIRING DIAGRAM

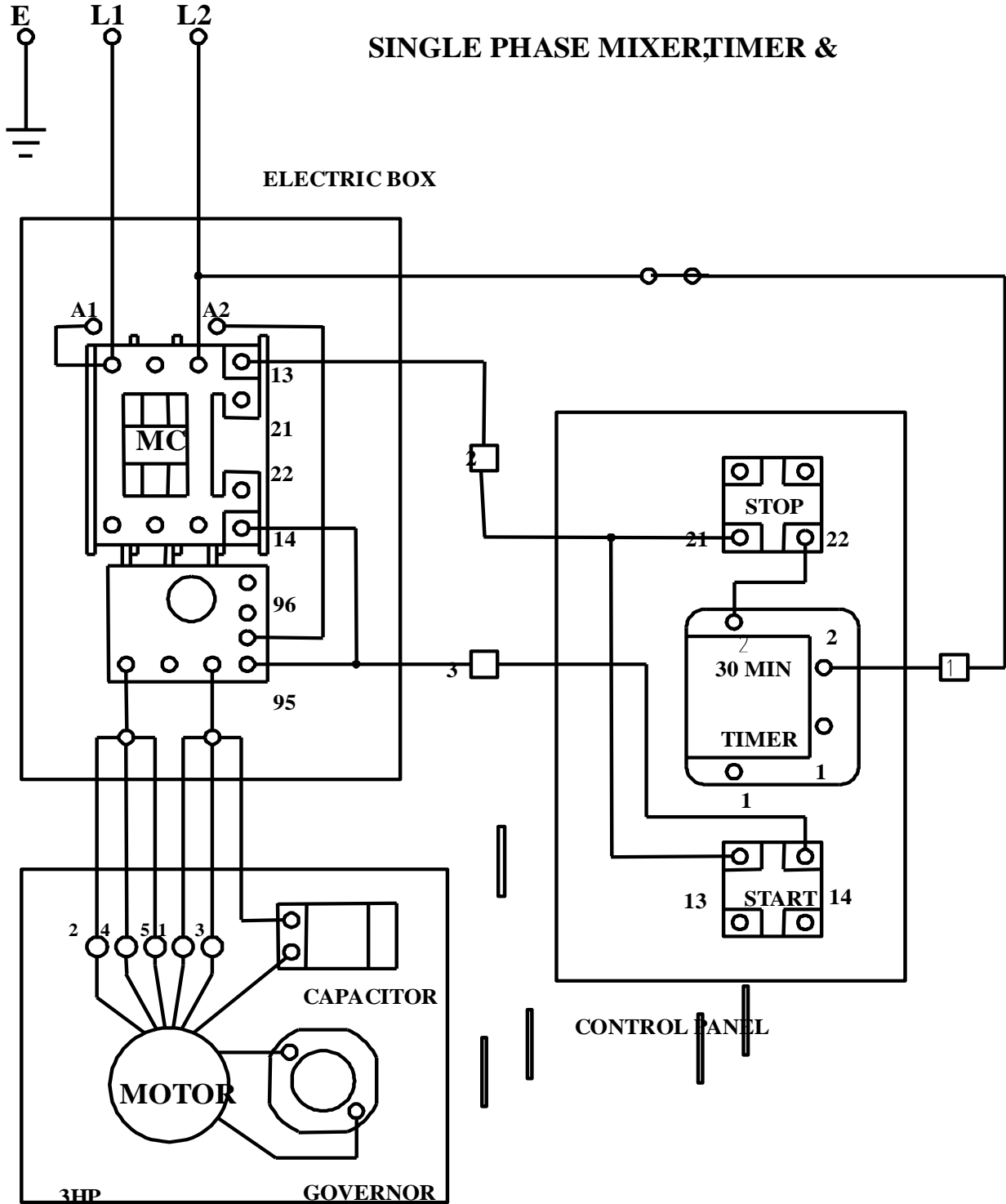

OPERATION

WARNING:

MOVING BEATER IN BOWL. KEEP HAND, CLOTHING, AND UTENSILS OUT WHILE IN OPERATION.

All models are furnished with two button switches, which control power to the mixer.

The GEAR SHIFT LEVER (No.3) is used to change speeds. Always stop the mixer before changing speeds. To change speeds, turn the switch OFF, move the gear shift lever to the desired speed, and turn the switch back ON.

- Speed 1 (low) - This speed is for heavy mixtures such as bread dough, heavy batters, and potatoes.
- Speed 2 (medium) - This speed is for light dough which must rise quickly, heavy batters, and some whipping operations.
- Speed 3 - This speed is fast for light work such as whipping cream, beating eggs, and mixing thin batters.

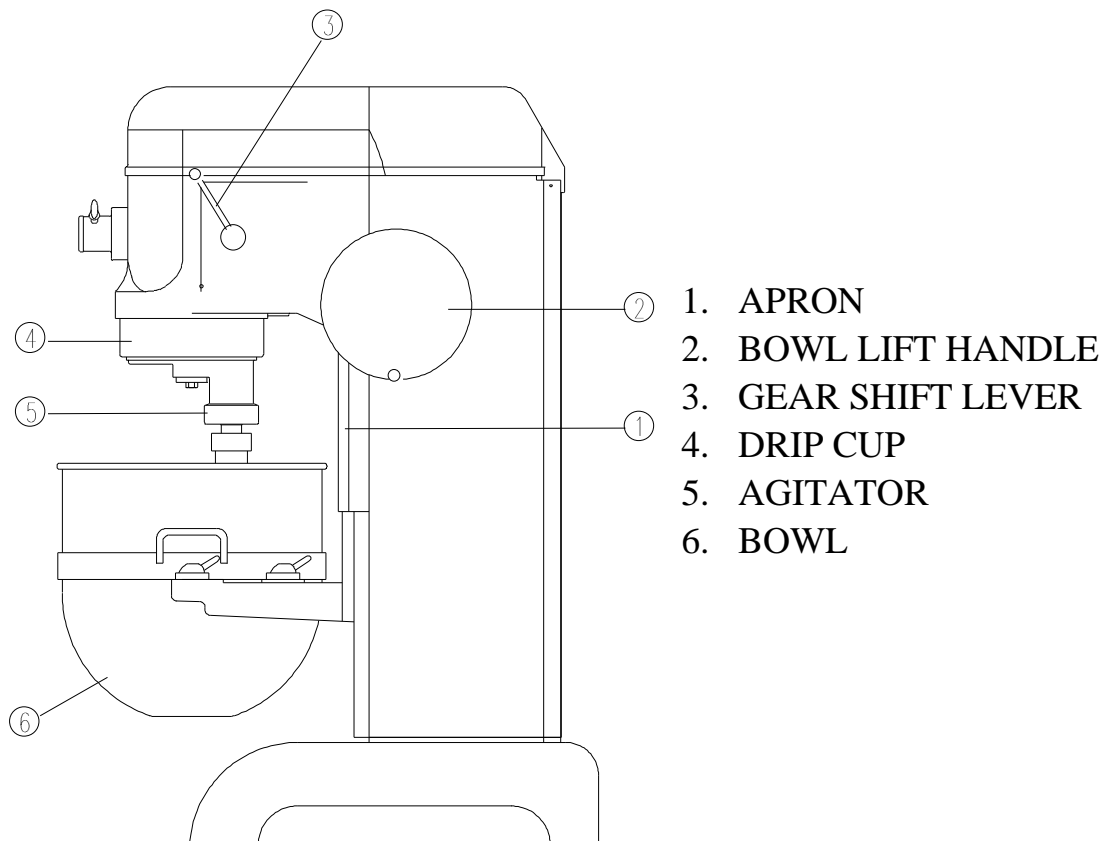

AGITATOR

To install an agitator (No 5), the bowl must be installed and fully lowered. Place the agitator in the bowl, push it up on the agitator shaft, and turn it clockwise to seat the shaft pin in the slot of the agitator shank.

DOUGH ARM:

It is frequently used for heavy bread dough, and preferable to be used at low speed.

The moisture content of heavy dough is critical when selecting proper mixing speed. You should never use 2nd speed when mixing heavy dough with an Absorption Ratio (AR) of 50% or less.

BEATER:

It is commonly used for thin batters, cake, and mashing potatoes, like stuffing and preferably to be used at middle speed.

WHIP:

It is best for whipping cream and beating eggs and preferably to be used at high speed.

BOWL - CAPACITY: 60 QUART

New mixers bowls and agitators (beaters, whip, and dough arms) should be thoroughly washed with hot water and mild soap solution, rinsed with either a mild soda or vinegar solution, and thoroughly rinsed with clean water **BEFORE** being put into service. This cleaning procedure should also be followed for bowls and agitators before whipping egg whites with or whole eggs.

The bowl must be installed before the agitator. To install the bowl, fully lower the bowl support. Position the bowl so the alignment bracket on the back of the bowl is in the bowl retainer and the alignment pins on the front of the bowl support fit in the holes on the sides of the bowl.

ATTACHMENTS

To install an attachment, loosen the thumb screw on the attachment hub and remove the plug. Insert the attachment into the attachment hub making certain that the square shank of the attachment is in the square driver of the mixer. Secure the attachment by tightening the thumb screw.

Move the gear shift lever to the desired speed and start the mixer to operate the attachment.

The meat and food chopper attachment should be operated in second or third speed. If material in the cylinder stalls the mixer, stop the mixer at once. DO NOT attempt to restart the mixer at a lower speed - remove the adjusting ring, knife, plate, and worm and clear the obstruction.

MAINTENANCE

NOTE : ALL MAINTENANCE WORK SHOULD BE DONE ONLY AFTER THE UNIT HAS BEEN DISCONNECTED FROM ELECTRICAL POWER AND GROUNDING.

Never use a metal or stiff brush to clean the mixer. Never clean the mixer with a water hose or any fluid pressure.

The mixer should be thoroughly cleaned daily.

Bowls and agitators should be removed from the mixer and cleaned in a sink.

The transmission case and planetary mechanism should be inspected weekly for leaks, damage, etc. Should it become necessary to repack the ball bearings, an authorized service technician or the manufacturer should be contacted. Use of unproved grease of lubricants may lead to damage and void the unit's warranty.

The **bowl lift slideways** should be lubricated semi-annually, or more often under heavy usage. Disconnect the unit from the power supply before removing the top housing or apron. The **drip cup** (Fig. 1) should be inspected periodically for moisture or lubricant dripping. Remove the cup and wipe it with a soft cloth.

CLEANING

The mixer should be thoroughly cleaned daily.

Bowls and agitators should be removed from the mixer and cleaned in a sink.

DO NOT use a hose to clean the mixer - it should be washed with a clean damp cloth.

The drip cup should be removed periodically and wiped clean. A large flat blade screwdriver may be used to remove the drip cup

MIXING HEAVY DOUGH

The moisture content of heavy dough is a critical factor when selecting proper mixing speed. You should never use 2nd speed when mixing heavy dough with an Absorption Ratio (AR) of 50% or less.

To determine the Absorption Ratio (AR) of a product, divide the water weight by the flour weight.

Example: Calculate the Absorption Ratio of a mixture containing 10 lbs. Of flour and 5 lbs. of water. $10 \div 5 = 0.50 = 50\% = \text{AR}$

CAPACITY (QTS. LIQUID)	Attachment	60 qt.
Egg Whites	Wire Whip	2 qt.
Mashed Potatoes	Flat Beater	40 lbs
Mayonnaise (Qt. Oil)	Flat Beater	18 qt.
Meringue (Qt. Water)	Wire Whip	1.5 qt.
Waffle/Pan cake Batter	Flat Beater	24 qt.
Whipped Cream	Wire Whip	12 qt.
Sheet Cake Batter	Flat Beater	45 lbs.
Cup Cake	Flat Beater	50 dz.
Layer Cake	Flat Beater	70 lbs.
Pound Cake	Flat Beater	55 lbs.
Sugar Cookie	Flat Beater	100 dz.
Bread or Roll Dough (Light/ Medium, 60% AR, □)	Dough Hook	80 bs.**
Bread or Roll Dough (Heavy, 55% AR, □)	Dough Hook	60 lbs.**
Pie Dough	Flat Beater	50 lbs.
Thin Pizza Dough (40% AR, □, 5 min. max. mix time)	Dough Hook	40 lbs.*
Medium Pizza Dough (50% AR, □)	Dough Hook	70 lbs.*
Thick Pizza Dough (60% AR, □)	Dough Hook	70 lbs.**
Raised Donut Dough (65% AR)	Dough Hook	30 lbs.*
Whole Wheat read Dough (70% AR)	Dough Hook	70 lbs.**
Egg & Sugar for Sponge Cake	Flat Beater	24 lbs.*

- * 1st speed ** 2nd speed
- If high gluten flour is used, reduce the dough batch size by 10 %.

Warranty & Service

BakeMax provides a 1-Year Limited Parts and Labor warranty on most items, there are select items which carry a Limited 2-Year Warranty. Extended Warranty is available on some products. Please contact us for details. The Warranty is not transferable and is limited to original installation of equipment sold by BakeMax for the original user.

For all Warranty Claims, Proof of Purchase and/or Serial Number is required. Once the machine is approved, BakeMax will provide our customers with on-site Warranty Coverage on all equipment more than 100lbs. BakeMax assumes no responsibility for down time or loss of product. Repairs must be Pre-Authorized by BakeMax and have a Service Authorization Number issued prior to commencing Warranty Service.

Warranty begins 10-Days after shipping from warehouse; delays in installation which would extend the Warranty must be Approved. All equipment must be installed and connected by Qualified Professionals in accordance with the Manual Specification. Products shipped are to be inspected at time of delivery, the receiver is responsible for inspection.

Any abuse or improper use of the equipment will void the warranty. This includes failure to follow all cleaning instructions, improper installation, improper maintenance, failure to follow capacity charts, improperly wired electrical connections. The Warranty does not apply to abuse, willful or accidental damage, or to products used for other than their intended purpose. Normal wear parts such as Accessories, Attachments, or Electrical Components such as Fuses, Bulbs, Elements, and Switches carry a 90-Day Warranty only.

Bench Warranty (Machines Weighing 100 lb. or less)

Once the machine is Approved for Warranty Service, if the machine requires Warranty work in less than 30 days of purchase date, BakeMax will pay all shipping charges. Once the machine is received and repaired it will be returned to the user at BakeMax expense. Freight Damages during return shipping is the responsibility of the owner of the machine.

The following is not covered under the BakeMax Warranty:

1. Overtime Labor Rates are not covered by BakeMax.
2. All parts will be shipped via Ground Courier only; If Express Shipping is required, it will be the responsibility of the Customer or Dealer.
3. Travel for Warranty Service is covered up to 100 Miles /160 Km Roundtrip, any further mileage will be the responsibility of the Customer or Dealer.
4. There is no on-site Warranty Service for Residential Addresses or addresses outside of the contiguous United States (*Lower 48*) or Canada.

***BakeMax machines sold outside of the contiguous United States (*Lower 48*), or Canada will carry 1-Year Parts Warranty only.*

Terms & Conditions

Terms

Net 15 days subject to Credit Approval. All past due Accounts are subject to 2% per month Service Charge as per Credit Application. We accept Visa, MasterCard, and Discover Credit Cards. We also accept E-Transfer & Wire Transfer, additional fees may apply.

Pricing

All prices are subject to change without notice. All prices are Sales Tax Extra, should you be claiming Tax Exemption, Tax Exempt Forms must accompany your Purchase Order. BakeMax products are sold in Canadian and US Dollars. BakeMax is not responsible for specifications errors or printing errors.

Shipping

Free shipping to Canada and the U.S. Minimum order \$6,000 for BakeMax and \$10,000 for BakeMax America Cooking Line. Tailgate Delivery is \$90.00 minimum. All checks made Payable to Titan Ventures International Inc. BakeMax is not responsible for goods damaged during shipping. BakeMax is not responsible for any delays in delivery once product has left our Warehouse and is in the carrier's possession.

Products shipped are to be inspected at time of delivery, the receiver is responsible for inspection. Damaged Freight Claims are to be claimed with the carrier. BakeMax assumes no responsibility for Damaged Freight. Shipping Insurance available by request. By signing your name on the delivery receipt without noting any damages, you are stating that you have received your shipment in Acceptable Condition.

Return Policy

Returns will not be Approved unless in Writing. Returns must be made within 30-Days of Purchase and must have a Return Authorization Number issued before returning. The purchase order number, reason for return, and the serial number(s) of the unit are required for the Return Authorization Number. Minimum return amount of \$100.00.

Returns are subject to a minimum restocking fee of 30%. The cost of any repairs or re-creating required will be charged back to the dealer. If there is a manufacturer's defect BakeMax® will pay standard freight returned and prepaid shipping back to the customer.

Special Order Items, Clearance / Discontinued Equipment, Parts, Refurbished/Demo Equipment, or Non-Standard items are not Returnable.

Ordering Information

Send purchase orders to BakeMax via e-mail orderdesk@bakemax.com or Fax (506-859-6929). Use Model or Part number when ordering including Voltage Requirements, and Product Description. Please include the Dealer, Name, Address, terms, special delivery, or instructions required or attention names to be applied to packaging. Please notify BakeMax should you need order confirmation or tracking numbers, by calling 1-800-565-2253 or email orderdesk@bakemax.com.

Special Terms and Conditions

BakeMax reserves the right to make improvements or equipment changes without prior permission. Setup and Installation are the end user's Responsibility. Failure to properly Install or Maintain Equipment may Void Warranty.

Catalog, Spec Sheets and Website

BakeMax is not liable for incorrect information found in our Catalog, Spec Sheets or Website. Please contact us to confirm specifications. Pictures and specifications are for general purposes only. Product may not be exactly as shown. Prices and availability may change at any time without notice. Dimensions shown may change at any time without notice.