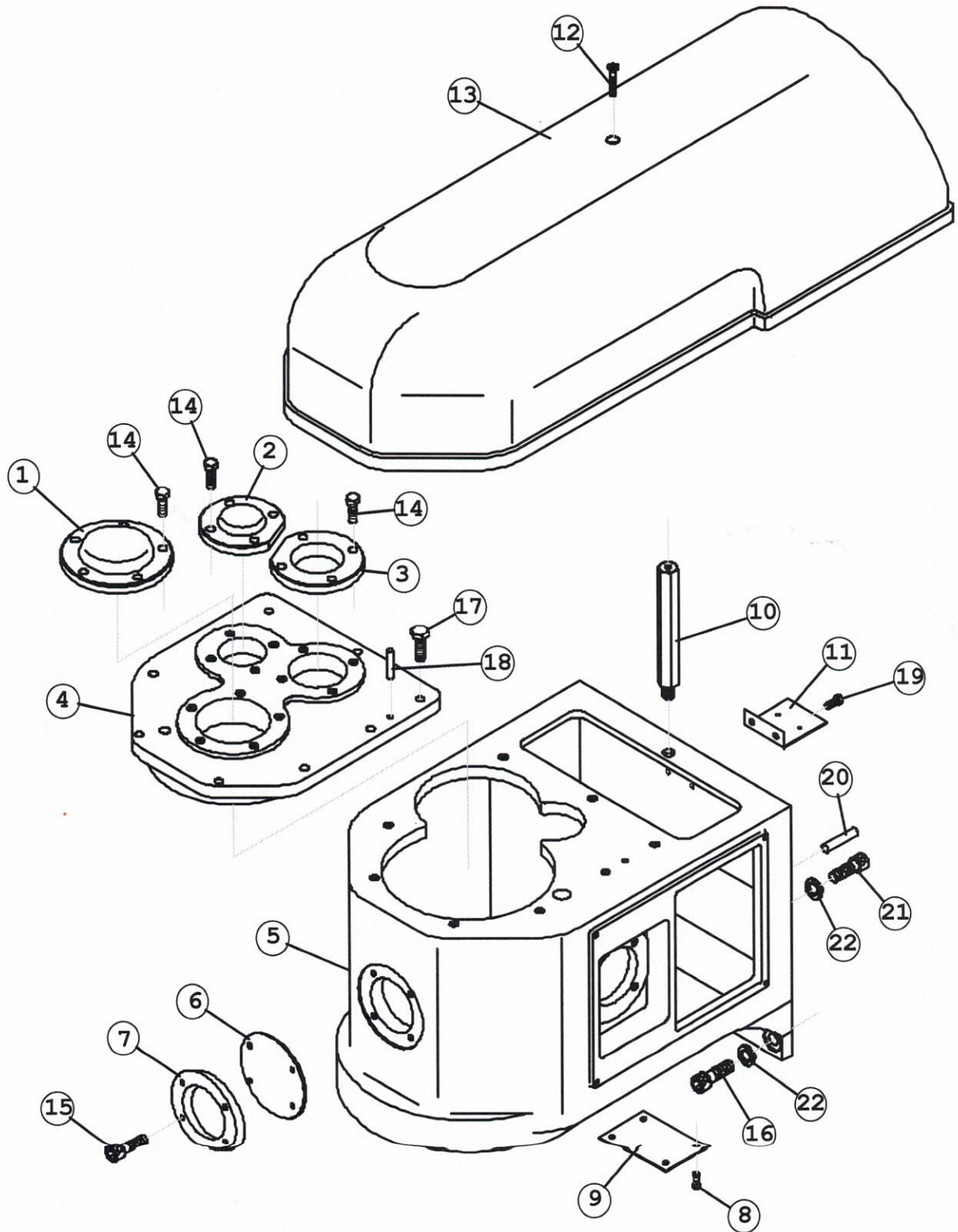
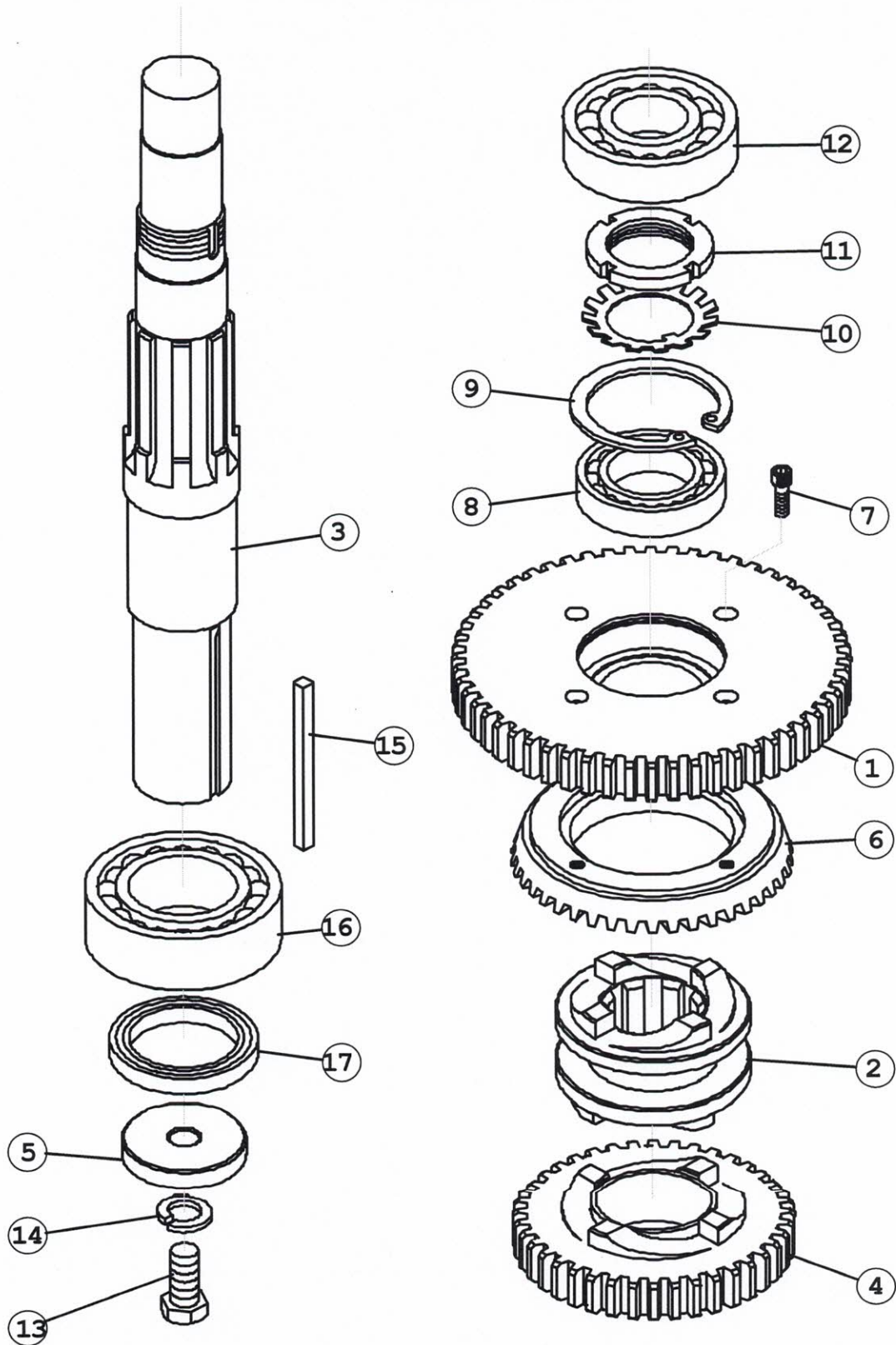

Figure 1. TRANSMISSION CASE



	Description or Name	HL Part No.	Qty	Unit Price US\$	Remark
1	Planetary Bearing Retainer	11092-01-001	1		
2	Bearing Retainer A	11092-01-002	1		
3	Bearing Retainer B	11092-01-003	1		
4	Gear Housing Cover	11092-01-004	1		
5	Transmission Case	11092-01-005	1		
6	Front Cover	11092-01-006	1		
7	Cover Retainer	11092-01-007	1		
8	Mach Screw 3/16*3/8	S+R3/16*3/8	4		
9	Plate	11091-01-009	1		
10	Support of Top Cover	11092-01-010	1		
11	Light Seat	11092-01-011	1		
12	Mach Screw 1/4*3/8	S+F1/4*3/8	1		
13	Top Cover	11091-01-001	1		
14	Bolt 5/16*3/4	S-5/16*3/4	13		
15	Cap Screw 5/16*5/8	S-C-5/16*5/8	4		
16	Cap Screw 1/2*1-1/4	S-C-1/2*1-1/4	2		
17	Bolt 3/8*1-1/4	S-3/8*1-1/4	8		
18	Spring Pin 6*28	SPP-6*28	2		
19	Bolt 1/4*3/8	S-1/4*3/8	2		
20	Spring Pin 10*50	SPP-10*50	2		
21	Cap Screw 1/2*2-1/4	S-C-1/2*2-1/4	4		
22	Spring Washer 1/2	SW-1/2	6		

Figure 2. PLANETARY SHAFT



	Description or Name	HL Part No.	Qty	Unit Price US\$	Remark
1	Gear	11093-02-001	1		
2	Clutch	11092-02-002	1		
3	Planetary Shaft	11100-02-003	1		
4	Gear	11093-02-004	1		
5	Spacer	11091-02-008	1		
6	Gear	11093-02-006	1		
7	Cap Screw 1/4*1	S-C-1/4*1	4		
8	Ball Bearing 6008Z	BR-6008Z	1		
9	C Snap Ring R68	CR-R68	1		
10	Lock Washer 40	M40	1		
11	Lock Nut M40	MN40*P1.5	1		
12	Ball Bearing 6307z	BR-6307Z	1		
13	Bolt 1/2*1-1/2	S-1/2*1-1/2	1		
14	Spring Washer 1/2	SW-1/2	1		
15	Key 1/4*1/4*90	KR-1/4*1/4*90	1		
16	Ball Bearing 5210Z	BR-5210Z	1		
17	Oil Seal TC50*70*10	OS-TC50*70*10	1		

Figure 3. TRANSMISSION SHAFT

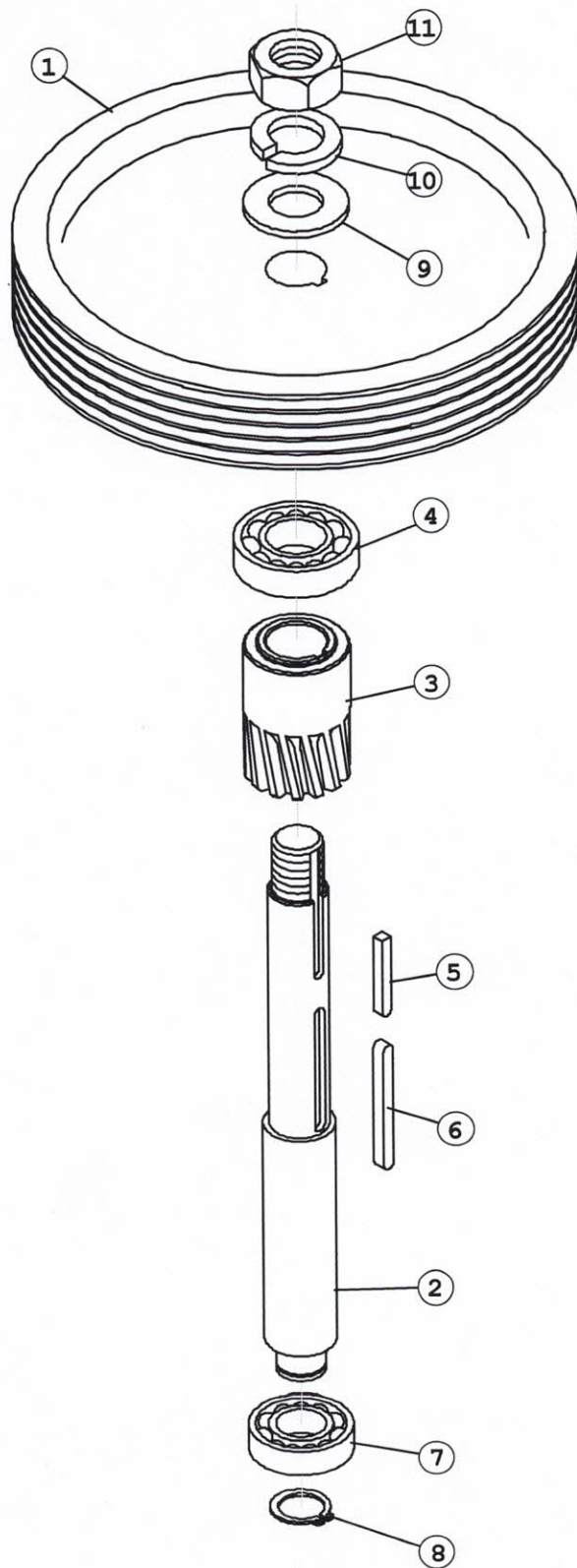

	Description or Name	HL Part No.	Qty	Unit Price US\$	Remark
1	Pulley	11100-03-001	1		
2	Shaft	11100-03-002	1		
3	Gear	11093-03-003	1		
4	Ball Bearing 6206Z	BR-6206Z	1		
5	Key 1/4*1/4*45	KR-1/4*1/4*45	1		
6	Key 7*7*75	KRR-7*7*75	1		
7	Ball Bearing 6205Z	BR-6205Z	1		
8	C-Type Snap Ring S25	CR-S25	1		
9	Washer 1	W-1	1		
10	Spring Washer 1	SW-1	1		
11	Nut 1*12NF	NUT-1*12NF	1		

Figure 4. REDUCTION GEAR SHAFT

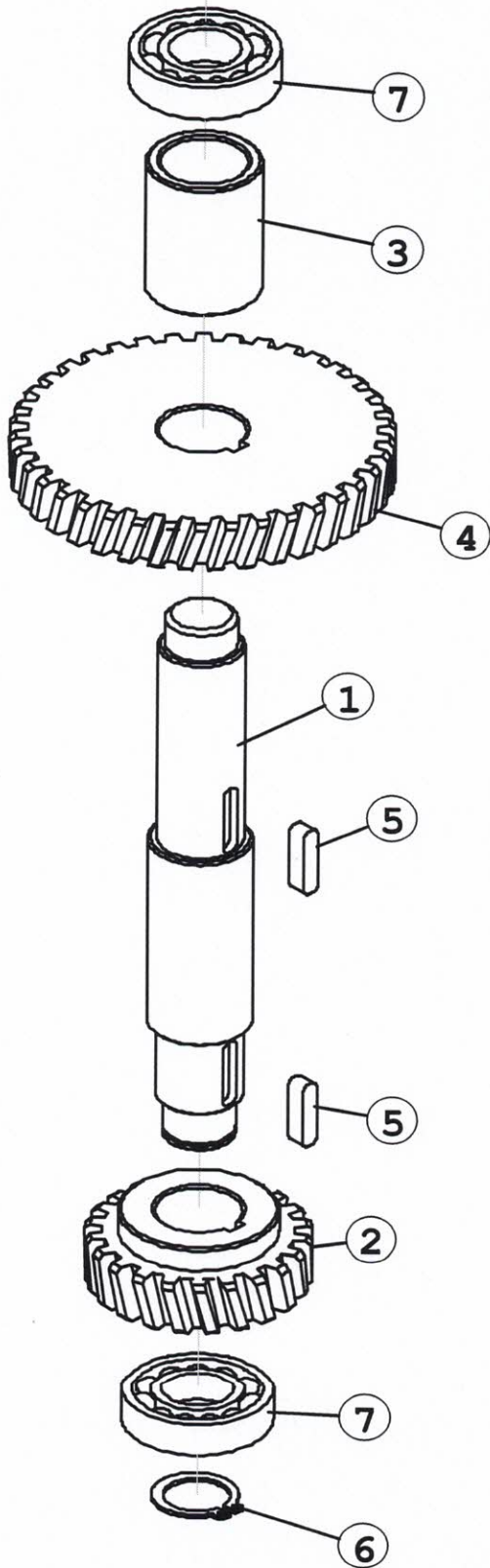

	Description or Name	HL Part No.	Qty	Unit Price US\$	Remark
1	Gear Shaft	11100-04-001	1		
2	Gear 22T	11093-04-002	1		
3	Spacer	11093-04-003	1		
4	Gear 39T	11093-04-004	1		
5	Key 7*7*30	KRR-7*7*30	1		
6	C-Type Snap Ring S25	CR-S25	1		
7	Ball Bearing 6205Z	BR-6205Z	1		

Figure 5. MOTOR UNIT

11100-05-000

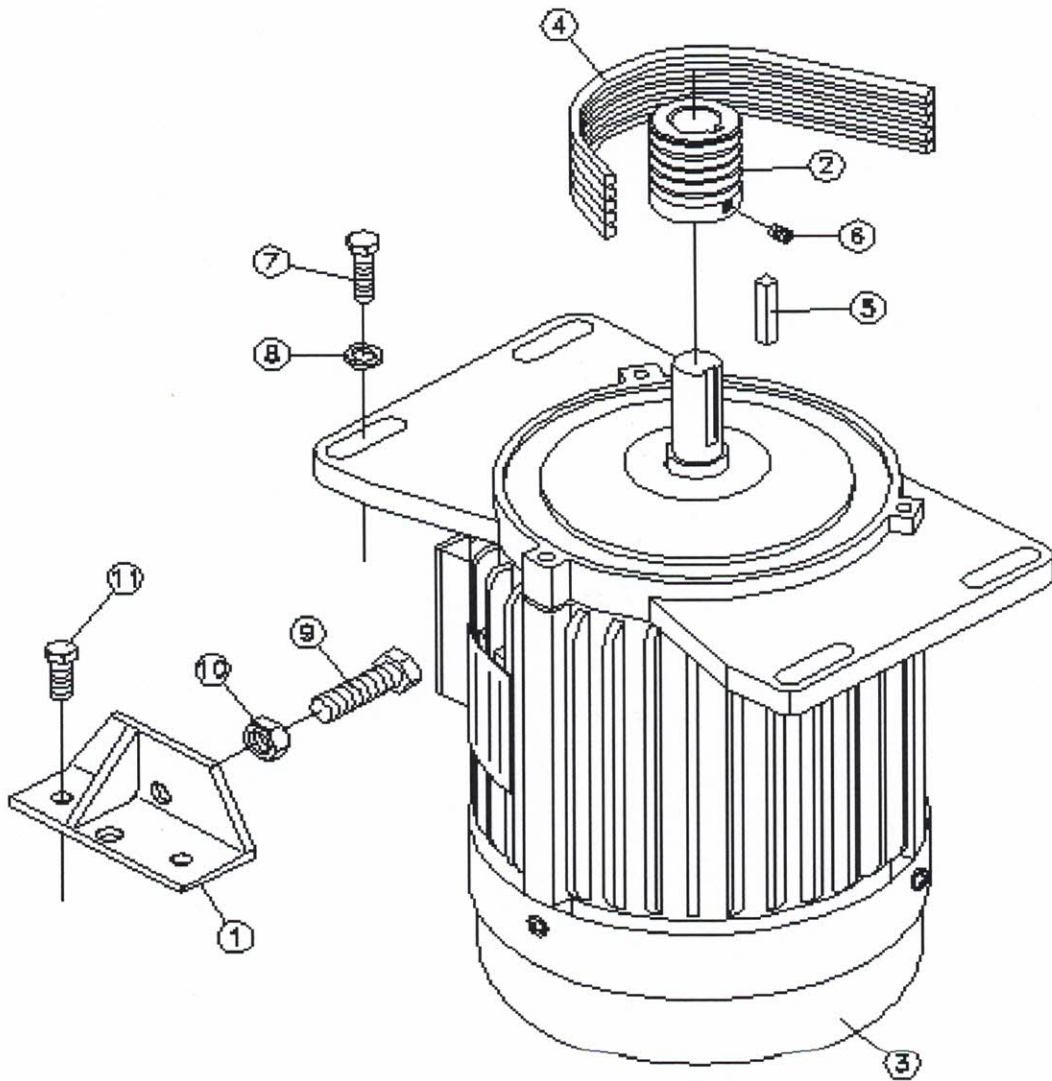

	Description or Name	HL Part No.	Qty	Unit Price US\$	Remark
1	Motor Support	11092-05-001	1		
2	Motor Pulley	11092-05-003	1		
3	Motor	11092-05-005	1		
4	Belt 7M*1320	BELT-7M*1320	5		
5	Key 7*7*40	KR-7*7*40	1		
6	Set Screw 1/4*5/16	S-S1/4*5/16	2		
7	Bolt 5/16*3/4	S-5/16*3/4	4		
8	Spring Washer 5/16	SW-5/16	4		
9	Bolt 1/2*4	S-1/2*4	1		
10	Nut 1/2*12NC	NUT-1/2*12NC	1		
11	Bolt 3/8*3/4	S-3/8*3/4	1		

Figure 6. HUB ATTACHMENT

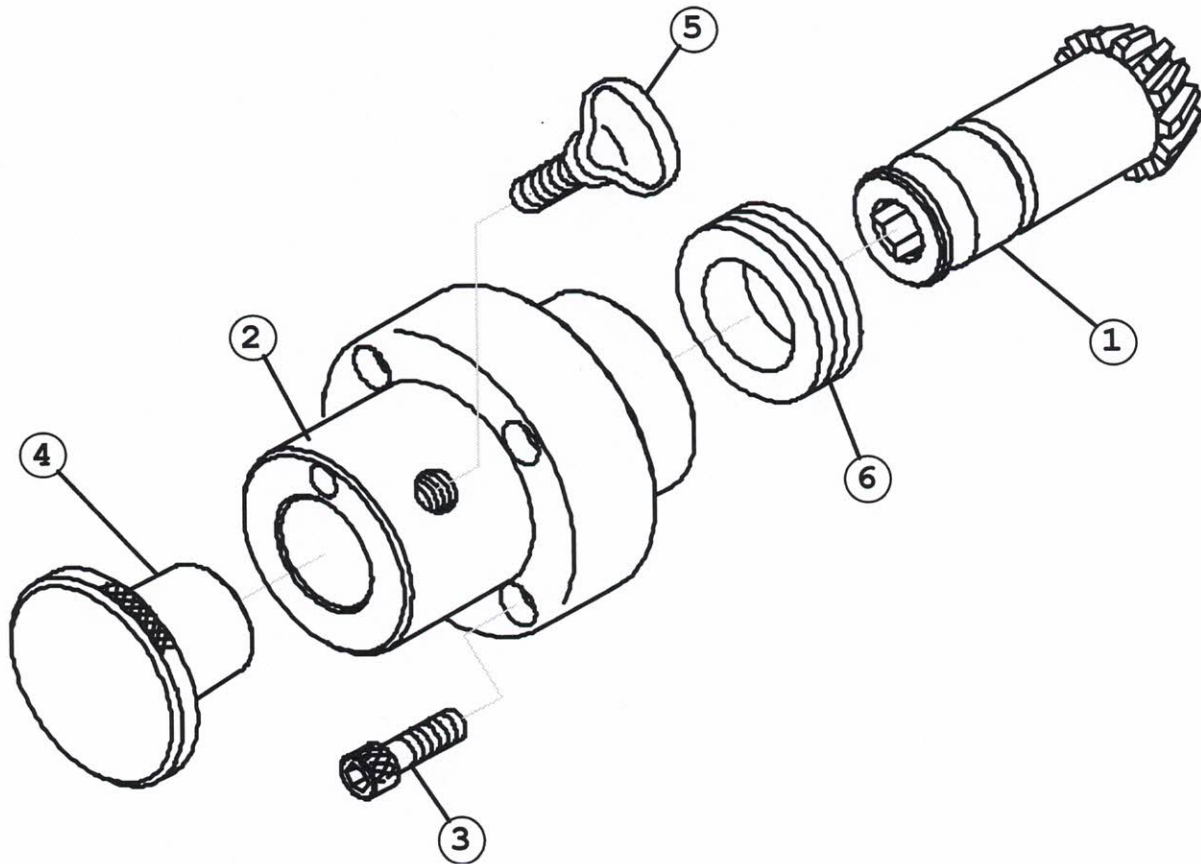

	Description or Name	HL Part No.	Qty	Unit Price US\$	Remark
1	Gear	11093-06-001	1		
2	Hub Attachment	11093-06-002	1		
3	Cap Screw 5/16*1-1/4	S-C-5/16*1-1/4	4		
4	Plug	11091-06-004	1		
5	Thumb Screw	11031-06-005	1		
6	Bearing 2907	BR-2907	1		

Figure 7. SHIFTER UNIT

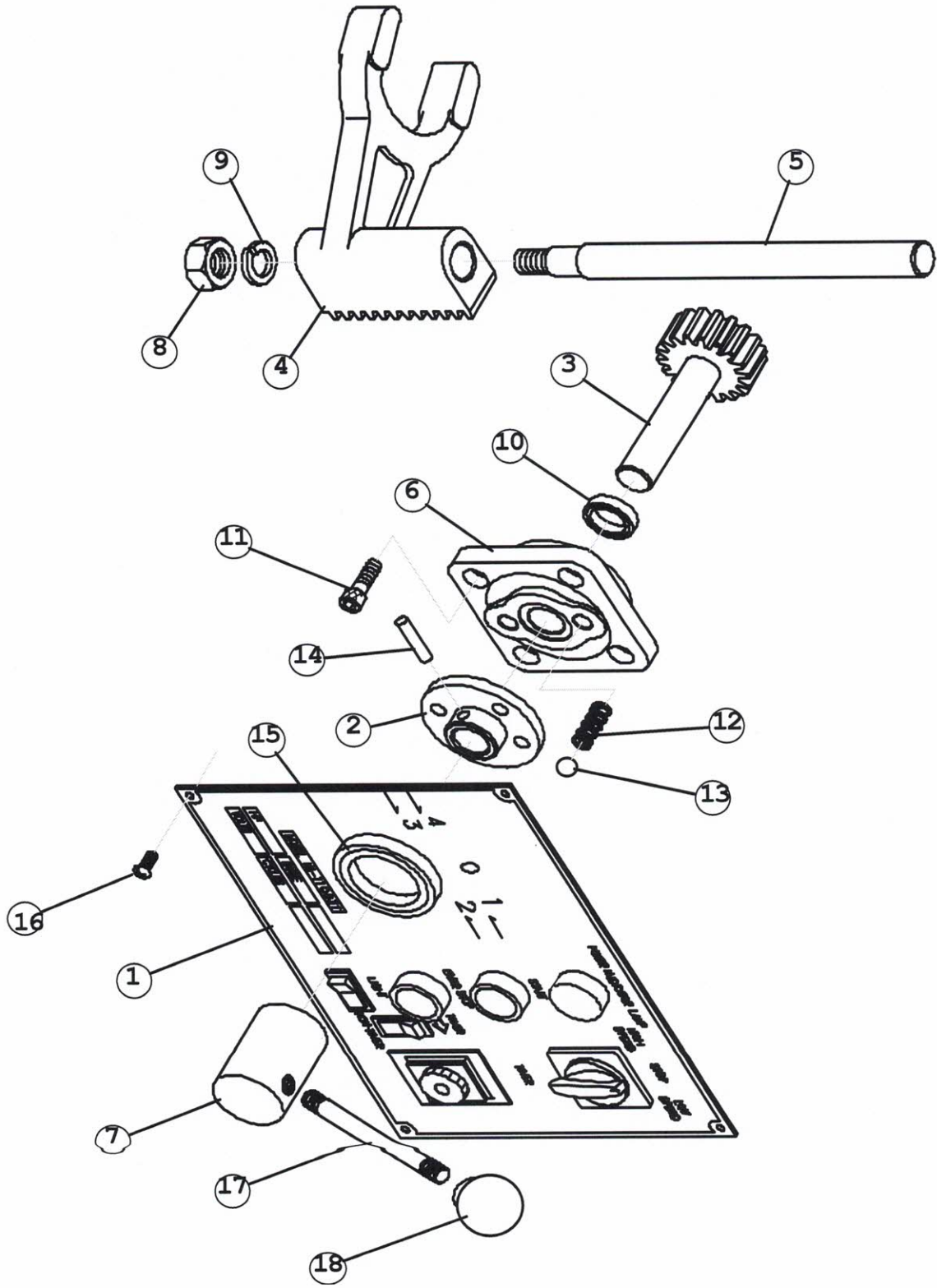

	Description or Name	HL Part No.	Qty	Unit Price US\$	Remark
1	Control Panel	11093-07-001	1		
2	Shifter Hub	11092-07-002	1		
3	Gear	11092-07-003	1		
4	Shift Fork	11092-07-004	1		
5	Shifter Shaft	11092-07-005	1		
6	Bracket	11092-07-006	1		
7	Handle Seat	11092-07-007	1		
8	Nut 1/2*12NC	NUT-1/2*12NC	1		
9	Spring Washer 1/2	SW-1/2	1		
10	Oil Seal TC19*27*07	OS-TC19*27*07	1		
11	Cap Screw 5/16*5/8	S-C-5/16*5/8	4		
12	Compressing Spring	11012-07-011	2		
13	Steel Ball 6	SB-6	2		
14	Spring Pin 4*28	SPP-4*28	1		
15	Oil Seal TC38*50*07	OS-TC38*50*07	1		
16	Mach Screw 3/16*3/8	S+R3/16*3/8	4		
17	Handle	11091-07-001	1		
18	Knob	11091-07-012	1		

Figure 8. PLANETARY HEAD

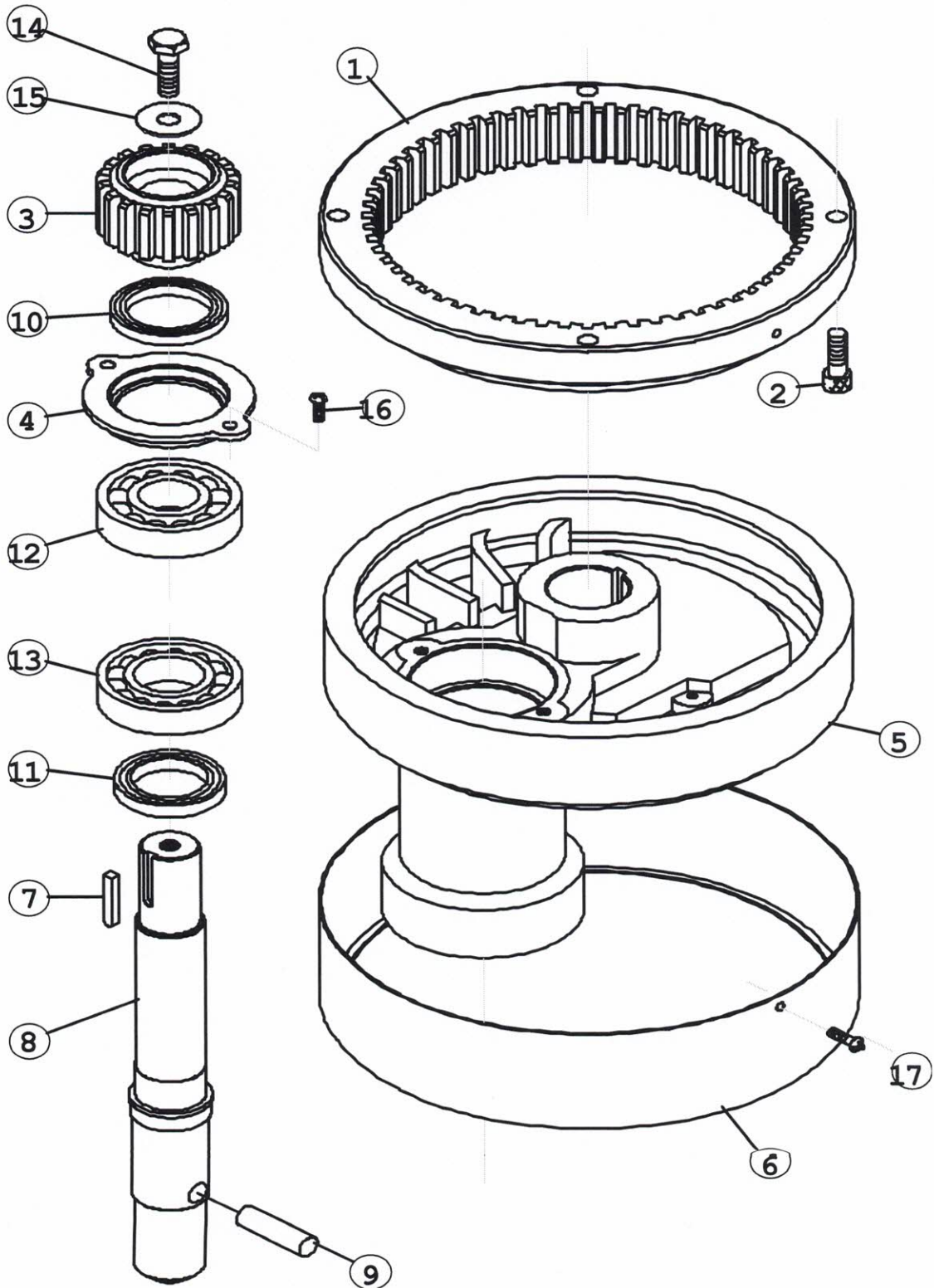

	Description or Name	HL Part No.	Qty	Unit Price US\$	Remark
1	Internal Drive Gear	11091-08-001	1		
2	Cap Screw 3/8*1-1/4	S-C-3/8*1-1/4	4		
3	Internal Pinion	11091-08-003	1		
4	Retainer	11091-08-004	1		
5	Planetary Head	11092-08-004	1		
6	Head Ring	11091-08-006	1		
7	Key 6*6*35	KR-6*6*35	1		
8	Agitating Shaft	11100-08-008	1		
9	Tapered Pin	11091-08-009	1		
10	Oil Seal TC43*58*08	OS-TC43*58*08	1		
11	Oil Seal TC40*72*08	OS-TC40*72*08	1		
12	Ball Bearing 6306Z	BR-6306Z	1		
13	Ball Bearing 6207Z	BR-6207Z	1		
14	Cap Screw 3/8*1	S-C-3/8*1	1		
15	Washer 3/8	WB-3/8	1		
16	Cap Screw 1/4*5/8	S-C-1/4*5/8	2		
17	Mach Screw 3/16*1/4	S+R3/16*1/4	2		

Figure 9. BASE AND PEDESTAL

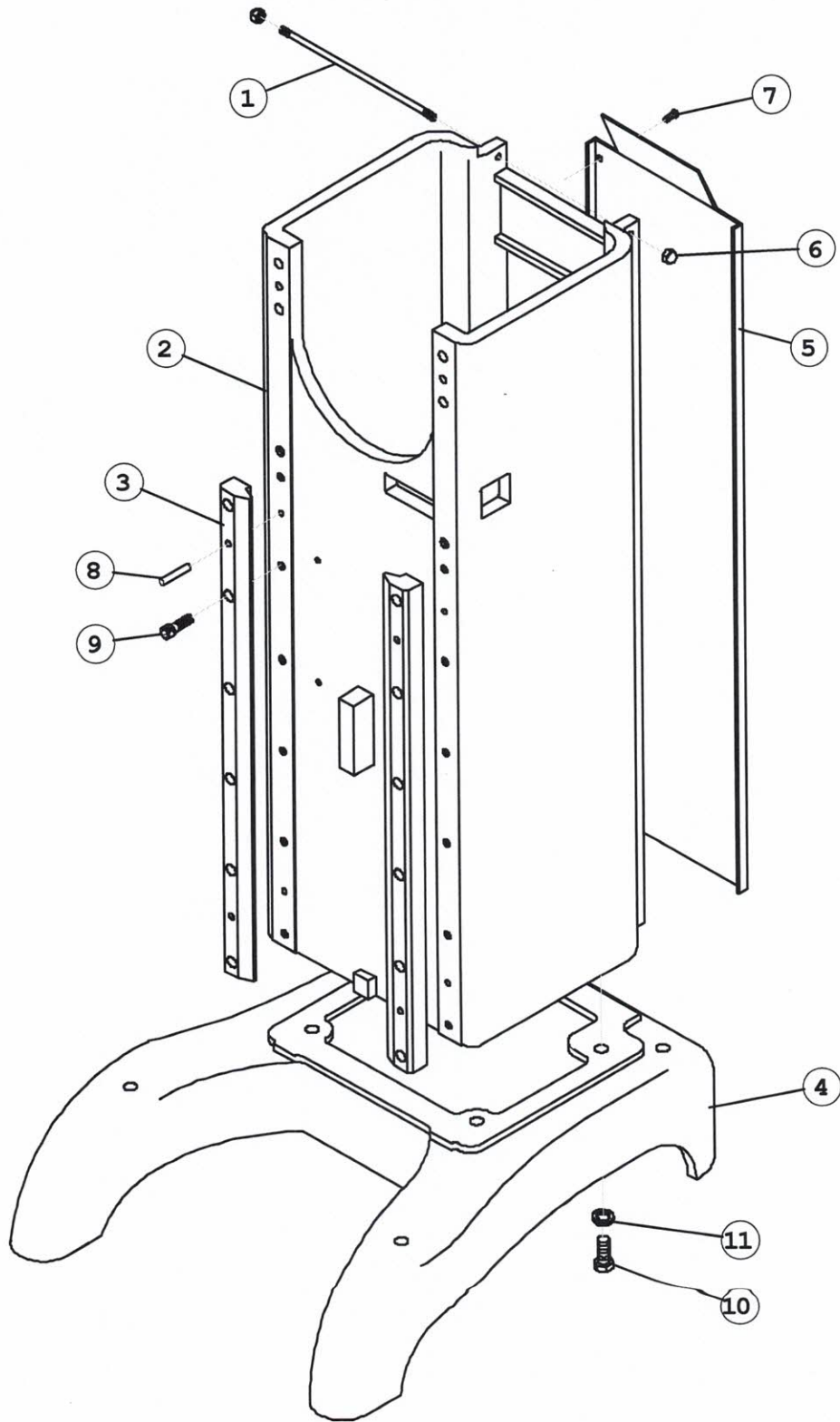
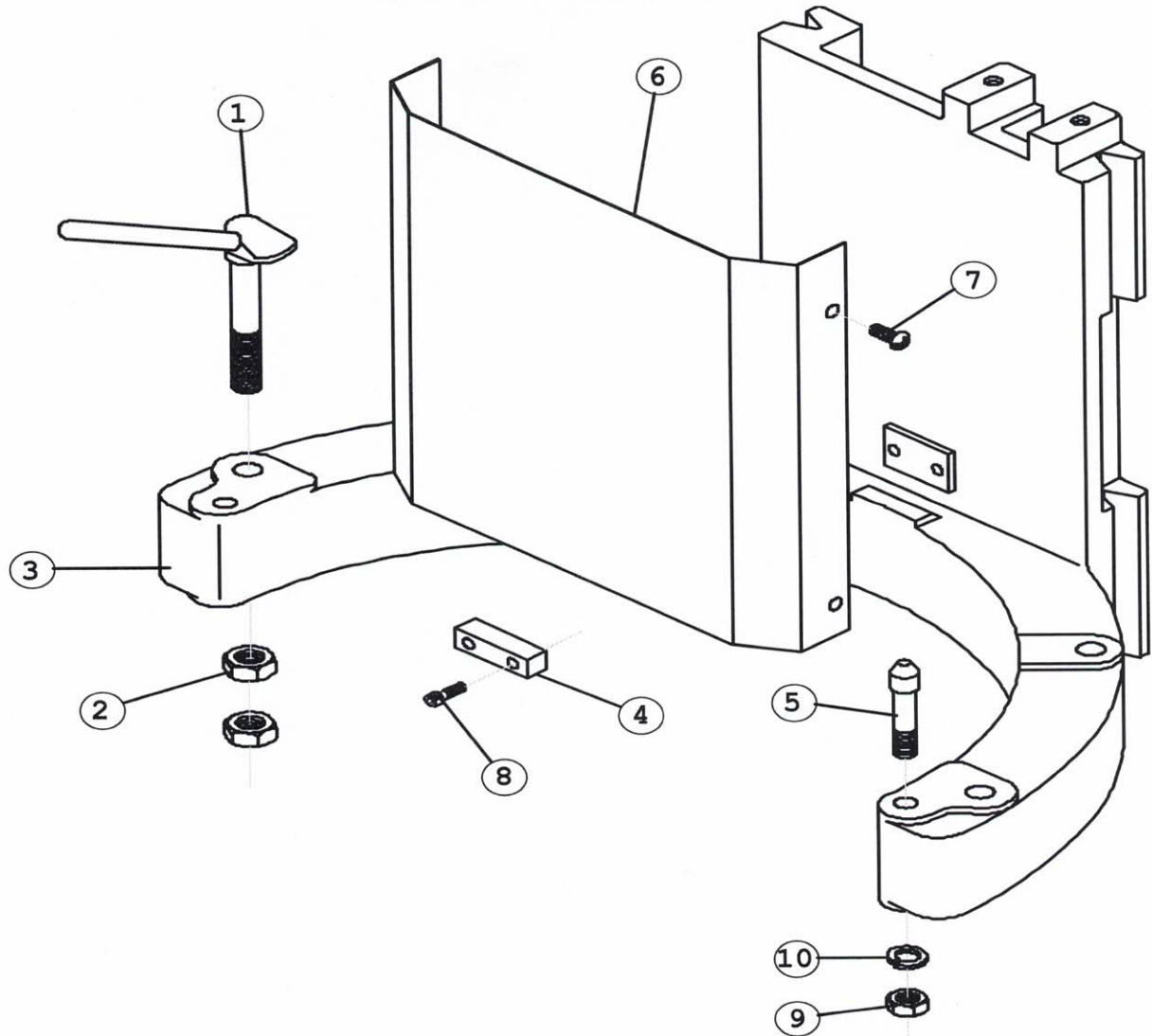

Figure 10. BOWL SUPPORT UNIT



	Description or Name	HL Part No.	Qty	Unit Price US\$	Remark
1	Bowl Clamp	11031-10-001	2		
2	Nut 5/8*11NC	NUT-5/8*11NC	4		
3	Bowl Support	11100-10-003	1		
4	Bowl Retainer	11091-10-004	1		
5	Bowl Locating Pin	11091-10-005	1		
6	Apron	11091-10-006	1		
7	Mach Screw 3/16*1/4	S+R3/16*1/4	4		
8	Cap Screw 1/4*5/8	S-C-1/4*5/8	2		
9	Nut 1/2*12NC	NUT-1/2*12NC	2		
10	Spring Washer 1/2	SW-1/2	2		

	Description or Name	HL Part No.	Qty	Unit Price US\$	Remark
1	Top Cover Fixed	11091-09-001	1		
2	Column	11092-09-002	1		
3	Slideway	11091-09-003	2		
4	Base	11100-09-004	1		
5	Column Cover	11091-09-005	1		
6	Nut 5/16*18NC	NUT-5/16*18NC	2		
7	Bolt 1/4*3/8	S-1/4*3/8	8		
8	Spring Pin 8*50	SPP-8*50	4		
9	Cap Screw 3/8*1-1/2	S-C-3/8*1-1/2	12		
10	Bolt 5/8*2-1/2	S-5/8*2-1/2	4		
11	Spring Washer 5/8	SW-5/8	4		

Figure 11-1. POWER BOWL LIFTER UNIT

11100T-11-000B

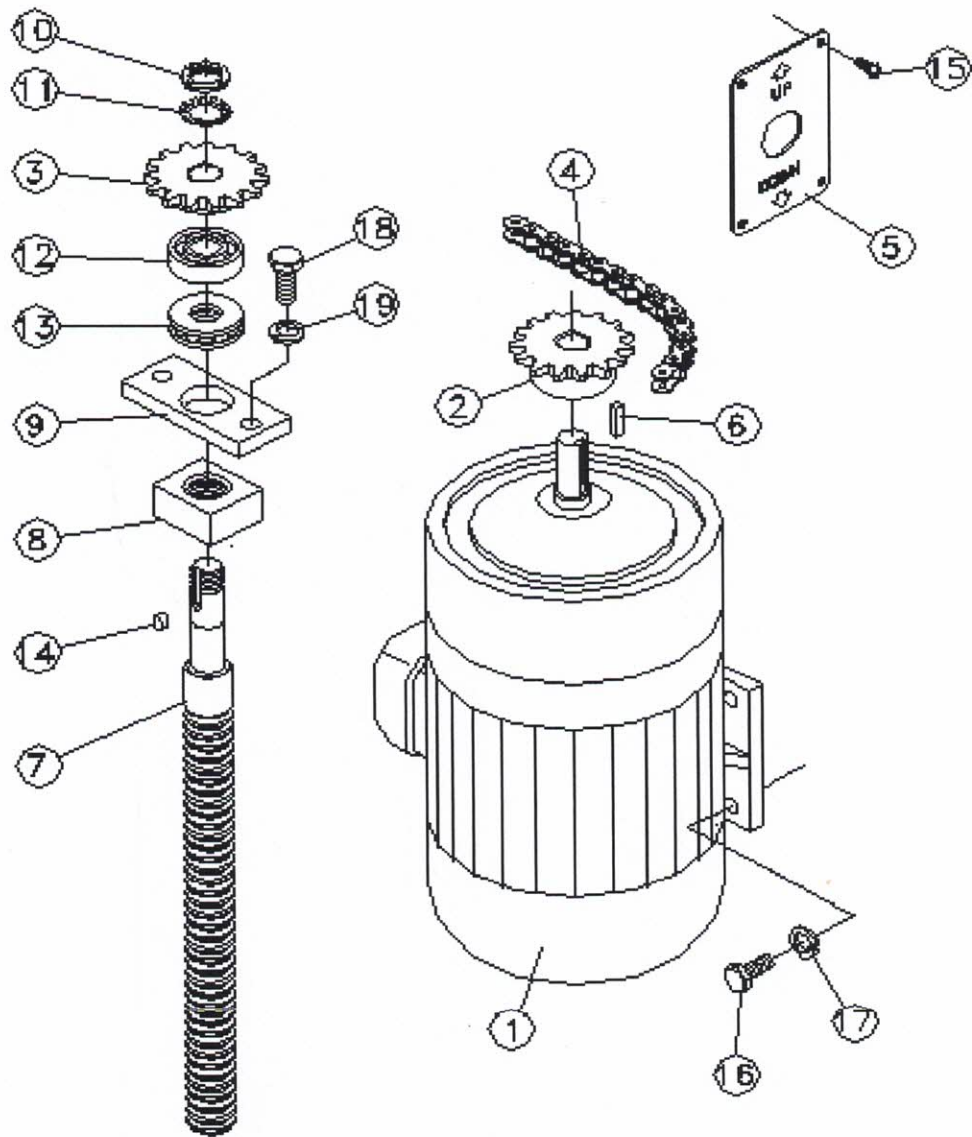

	Description or Name	AE Part No.	Qty	Unit Price US\$	Remark
1	Reducer Motor	11091-01-001A	1		
2	Chain gear	11091-11-016	1		
3	Chain gear	11091-11-017	1		
4	Chain	BL-04-008	1		
5	Lifting Panel	11091-11-015	1		
6	Key 7*7*25	KR-7*7*25	1		
7	Lifting Screw	11091-11-007	1		
8	Lifting Nut	11091-11-008	1		
9	Retainer	11091-11-009	1		
10	Lock Nut M17	MN17	1		
11	Lock Washer Ø17	M17	1		
12	Ball Bearing #6203Z	BR-6203Z	1		
13	Ball Bearing #2903	BR-2903	1		
14	Key 5*5*15	KRR-5*5*15	1		
15	Mach Screw 5/16*1/4	S+R5/16*1/4	4		
16	Bolt 1/2*3/4	S-1/2*3/4	8		
17	Spring Washer 1/2	SW-1/2	8		
18	Bolt 3/8*5/8	S-3/8*5/8	2		
19	Spring Washer 3/8	SW-3/8	2		

Figure 11. BOWL LIFTER UNIT

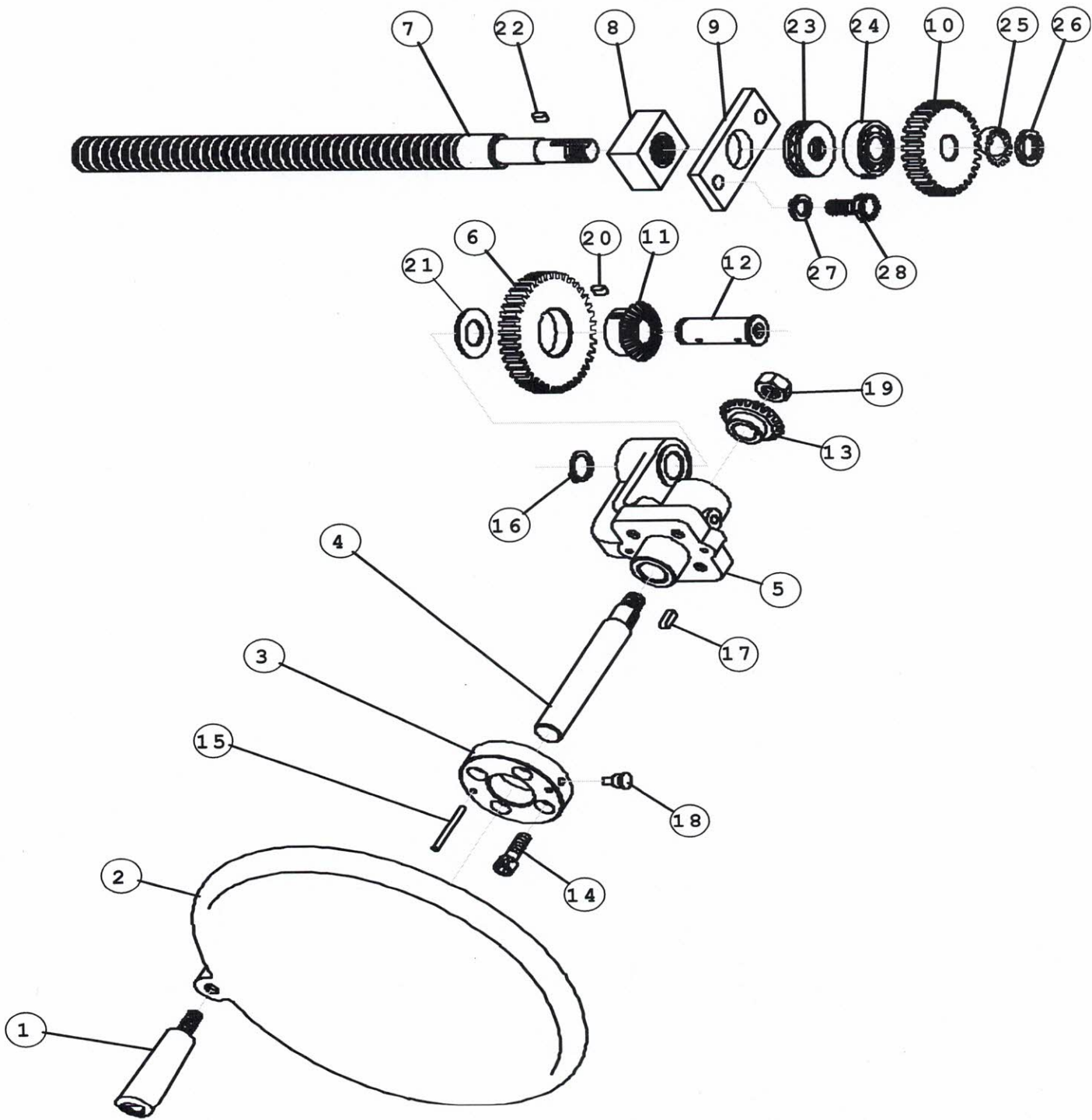

	Description or Name	HL Part No.	Qty	Unit Price US\$	Remark
1	Wheel Handle	11091-11-001	1		
2	Lifting Wheel	11091-11-002	1		
3	Clamping Arm	11091-11-003	1		
4	Wheel Shaft	11091-11-004	1		
5	Wheel Bracket	11091-11-005	1		
6	Lifting Gear	11091-11-006	1		
7	Lifting Screw	11092-11-007	1		
8	Lifting Nut	11091-11-008	1		
9	Retainer	11100-11-009	1		
10	Gear	11091-11-010	1		
11	Bevel Gear -Lifting	11091-11-011	1		
12	Shaft	11091-11-012	1		
13	Bevel Gear -Wheel	11091-11-013	1		
14	Set Screw	S-C-5/16*1	4		
15	Tapered Pin	TP-4*32	2		
16	C Snap Ring	CR-S19	1		
17	Key	KR-5*5*15	1		
18	Oil Cup	(五)OIL-BELL-1/8*3/4	1		
19	Nut	NUT-1/2*12NC	1		
20	Key	KRR-5*5*10	1		
21	Washer 3/4"	W-3/4	1		
22	Key 5*5*13	KRR-5*5*13	1		
23	Ball Bearing 2903	BR-2903	1		
24	Ball Bearing 6203	BR-6203	1		
25	Lock Washer 17	M17	1		
26	Lock Nut 17	MN17	1		
27	Spring Washer 3/8	SW-3/8	2		
28	Cap Screw 3/8*1	S-C-3/8*1	2		

Figure 12. STANDARD ACCESSORIES

11100-12-000

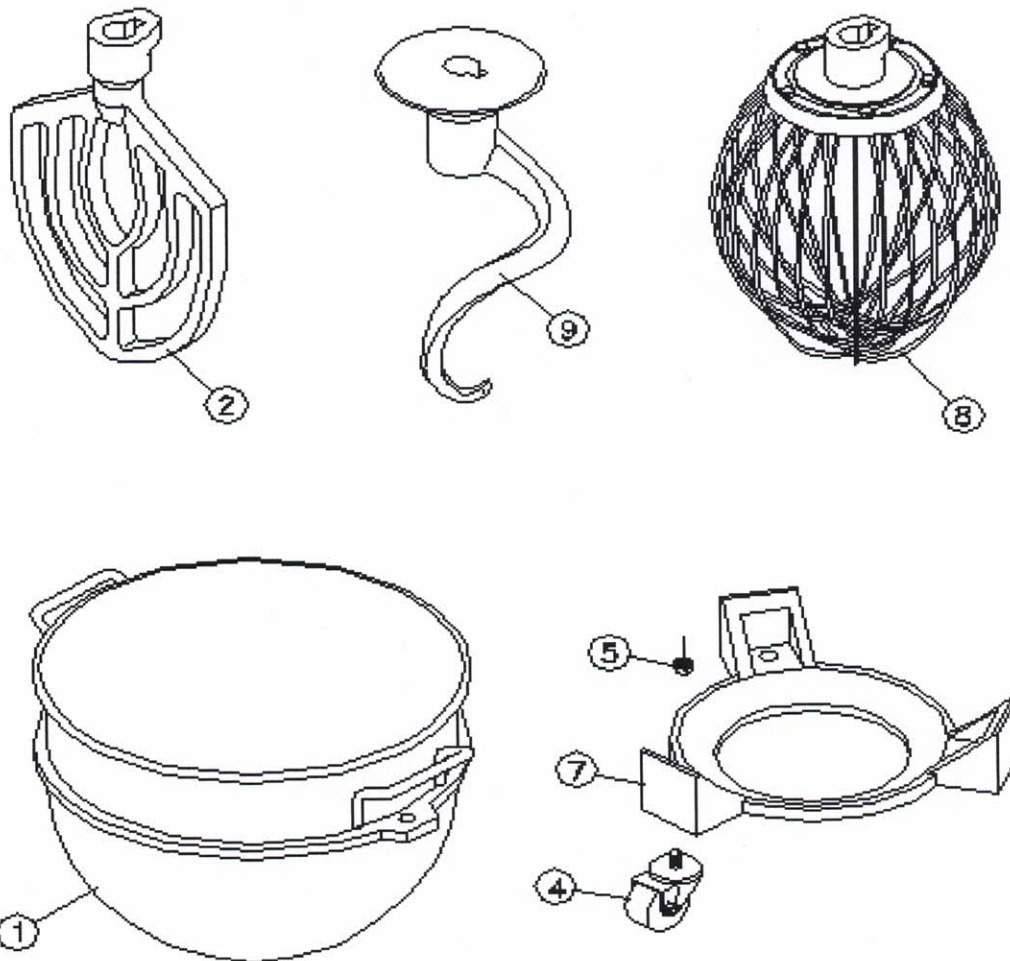

	Description or Name	HL Part No.	Qty	Unit Price US\$	Remark
1	SS Bowl	11100-12-001	1		
2	AL Flat Beater	11100-12-002	1		
4	Wheel	WHEEL-001	3		
5	Nut 1/2*12NC	NUT-1/2*12NC	3		
7	Trolley Base	11091-12-011	1		
8	SS Wire Whip	11100-12-004	1		
9	Spiral Dough Hook	11100-12-003	1		

Figure 13. SAFETY GUARD UNIT

11100-13-000

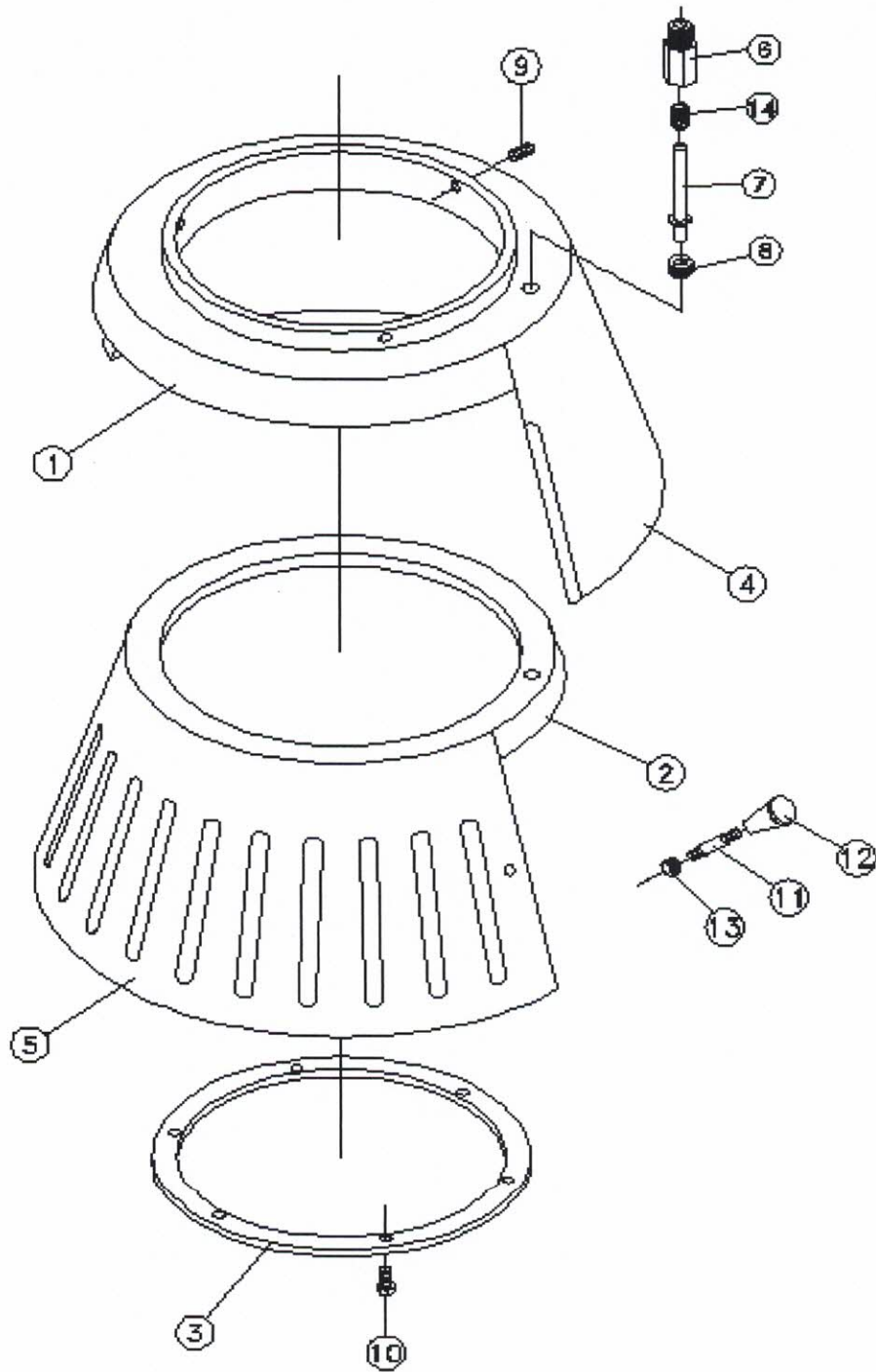

	Description or Name	HL Part No.	Qty	Unit Price US\$	Remark
1	Head Ring	11091-13-001A	1		
2	Moving Ring	11091-13-002A	1		
3	Fixed Ring	11091-13-003A	1		
4	Fixed Sheet	11100-13-004	1		
5	Moving Sheet	11100-13-005	1		
6	Control Shaft Seat	1109P-13-006	1		
7	Control Shaft	1109P-13-007	1		
8	Control Shaft Screw	1109P-13-008	1		
9	Set Screw 5/16*3/8	S-S5/16*3/8	3		
10	Bolt 3/16*1/2	S-3/16*1/2	6		
11	Handle	11012-07-002	1		
12	Handle Knob	11012-07-001	1		
13	Nut 5/16*18NC	NUT-5/16*18NC	1		
14	Compressing Spring	11091-13-012	1		

Figure 14 Electrical Parts

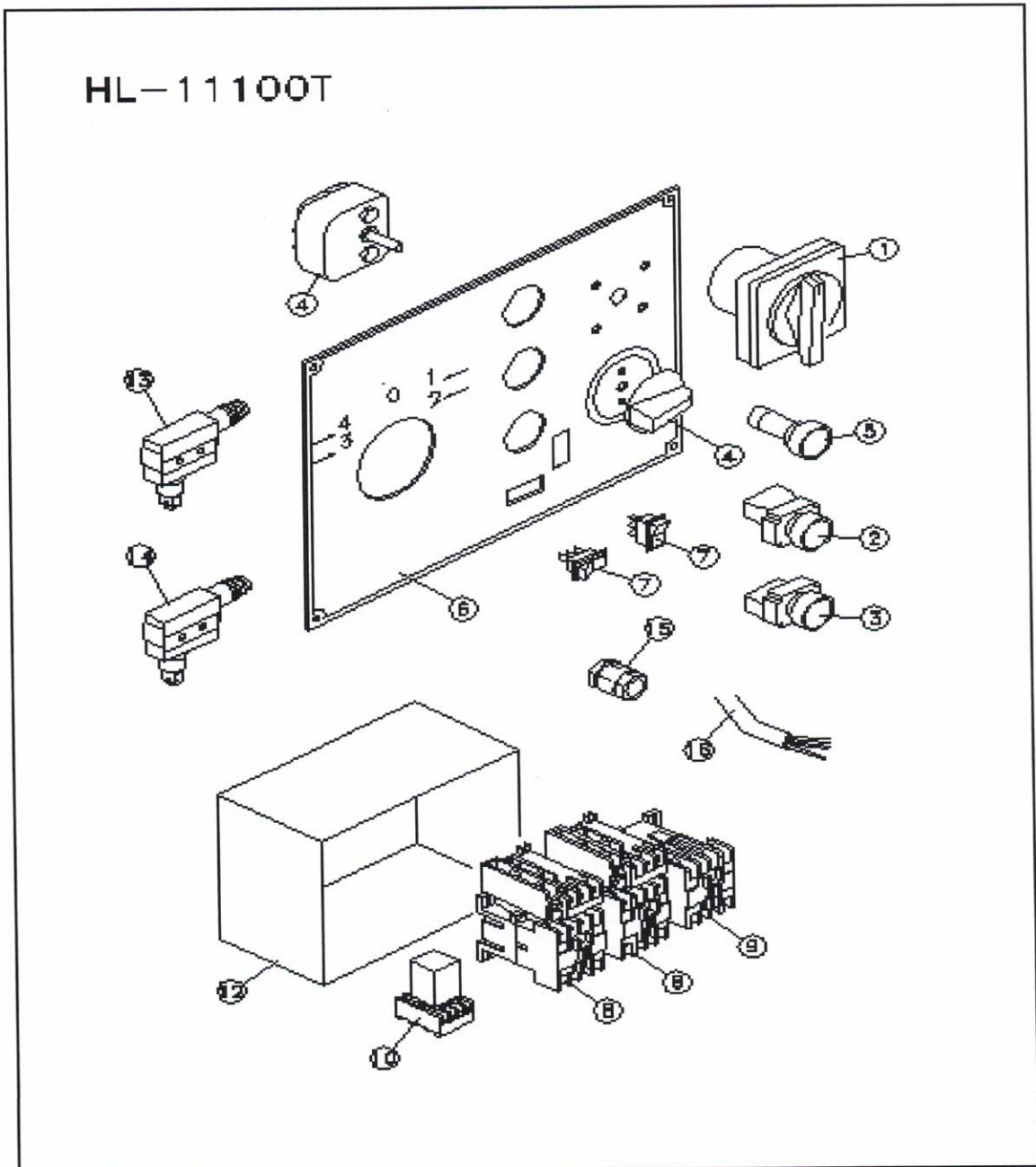

Illus. No.	Description or Name	Parts No.	Qty	Unit Price US\$	Remark
1	Switch	GN20-2298-U24	1		
2	Red Button	TE XB2 ES542	1		
3	Green Button	TE XB7 EA31	1		
4	Timer	HS3-2	1		
5	Indicator Lamp	TEXB2EV163	1		
6	Control Panel	11093-07-001	1		
7	On-Off Switch	IB3C	1		
8	Contactora	HNO16+5HP	1		
8	Contactora	HNO11+1HP	1		
9	Contactora	CN11	1		
10	Timer	MK2P	1		
12	Electric Box	35N	1		
13	Limit Switch Of Lifter	TE XCK-P145	1		
14	Limit Switch Of Guard	MJ-7106	1		
15	Collar	CG-20	1		
16	Power Cable	CABLE-12-3C-UL	1		

HL-11100T

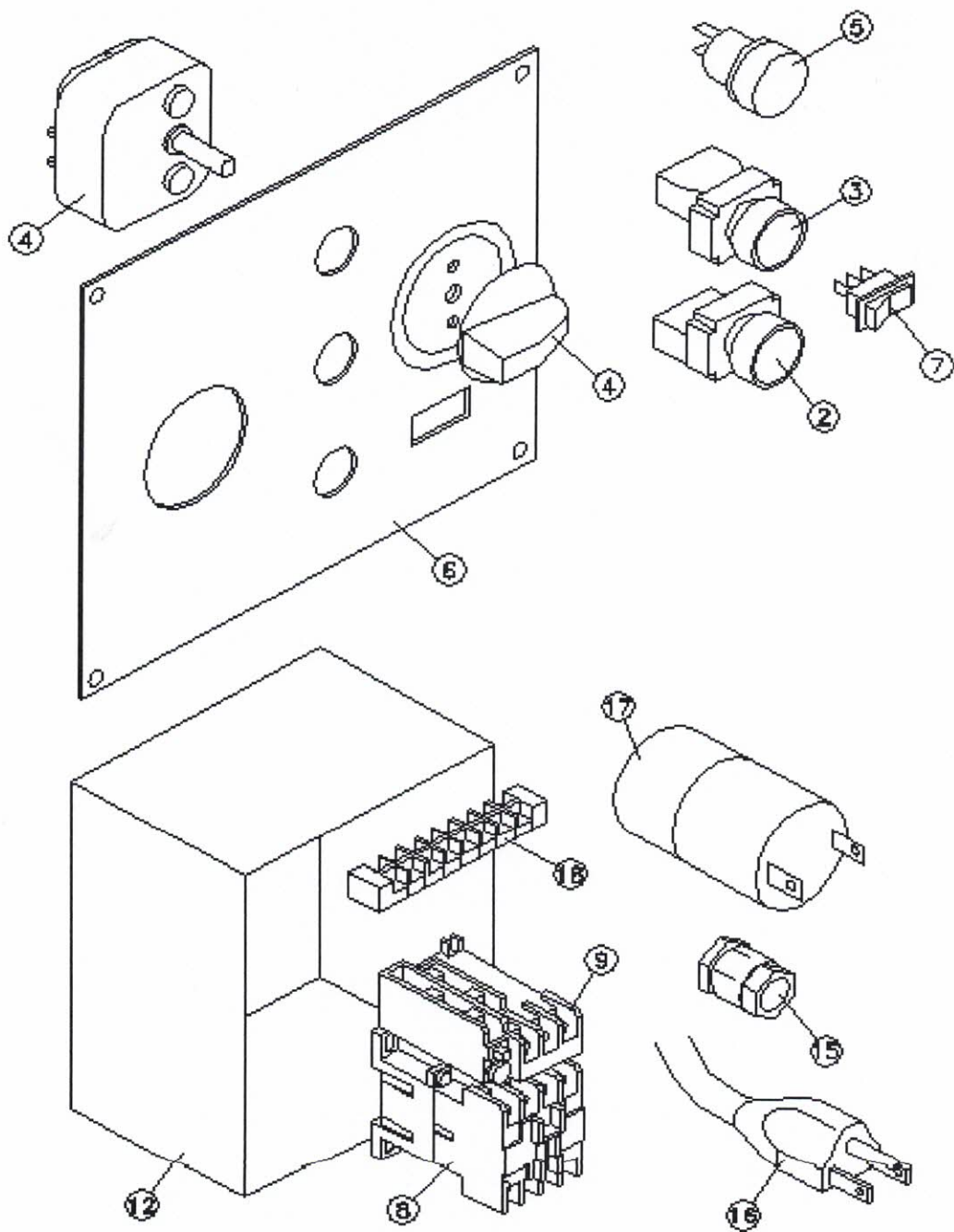

Illus. No.	Description or Name	Parts No.	Qty	Unit Price US\$	Remark
2	Green Button	TE XB7 EA31	1		
3	Red Button	TE XB2 ES542	1		
4	Timer	HS3-2	1		
5	Indicator Lamp	TEXB2EV163	1		
6	Control Panel	11093-07-001	1		
7	On-Off Switch		1		
8	Contactor	CN11	1		
9	Overload Relay		1		
12	Electric Box	35N	1		
15	Collar		1		
16	Power Cable		1		
17	Terminal Block		1		
18			1		

HL-11100AT

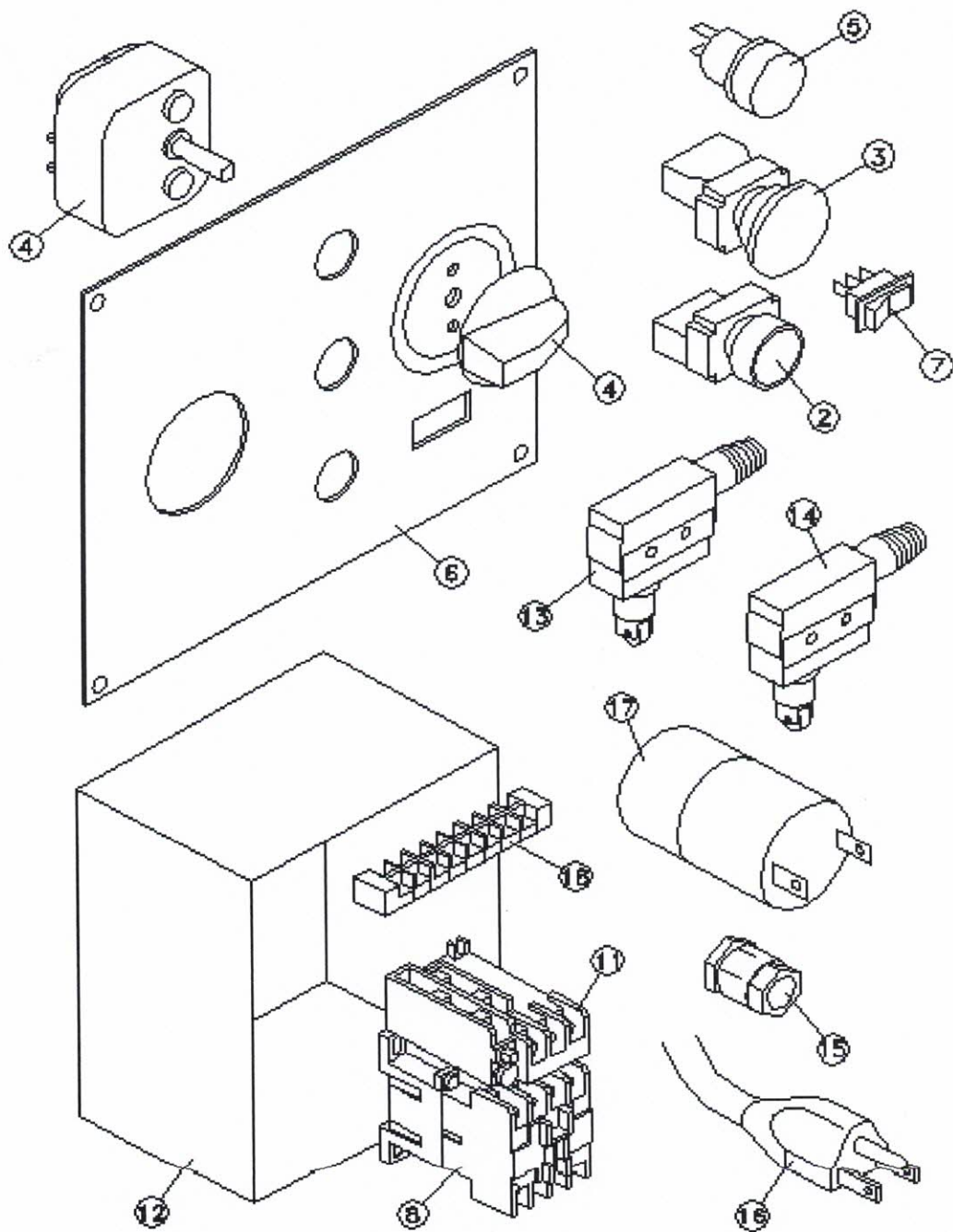

Illus. No.	Description or Name	Parts No.	Qty	Unit Price US\$	Remark
2	Button Switch	TE XB7 EA31	1		
3	Emergency Stop	TE XB2 ES542	1		
4	Timer	HS3-2	1		
5	Indicator Lamp	TEXB2EV163	1		
6	Control Panel	11093-07-001	1		
7	On-Off Switch		1		
8	Contactor	CN11	1		
			1		
12	Electric Box	35N	1		
13	Limit Switch Of Lifter	MJ-7106	1		
14	Limit Switch Of Guard	TE XCK-P145	1		
15	Collar		1		
16	Power Cable		1		
17	Capacitor		1		
18	Terminal Block		1		

Image 11-A	Description or Name		Qty	Unit Price US\$	Remark
1	Reducer Motor		1		
2	Key 7*7*25		1		
3	Chain gear		1		
4	Chain		1		
6	Bolt 5/16*1		8		
7	Spring Washer 5/16		8		
8	Lifting Screw		1		
9	Key 5*5*13		1		
10	Lifting Nut		1		
11	Retainer		1		
12	Ball Bearing #2903		1		
13	Ball Bearing #6203Z		1		
14	Chain gear		4		
15	Lock Washer Ø17		1		
16	Lock Nut M17		1		
17	Bolt 3/8*1		2		
18	Spring Washer 3/8		2		

HL-11100

6094 Mick
American Book

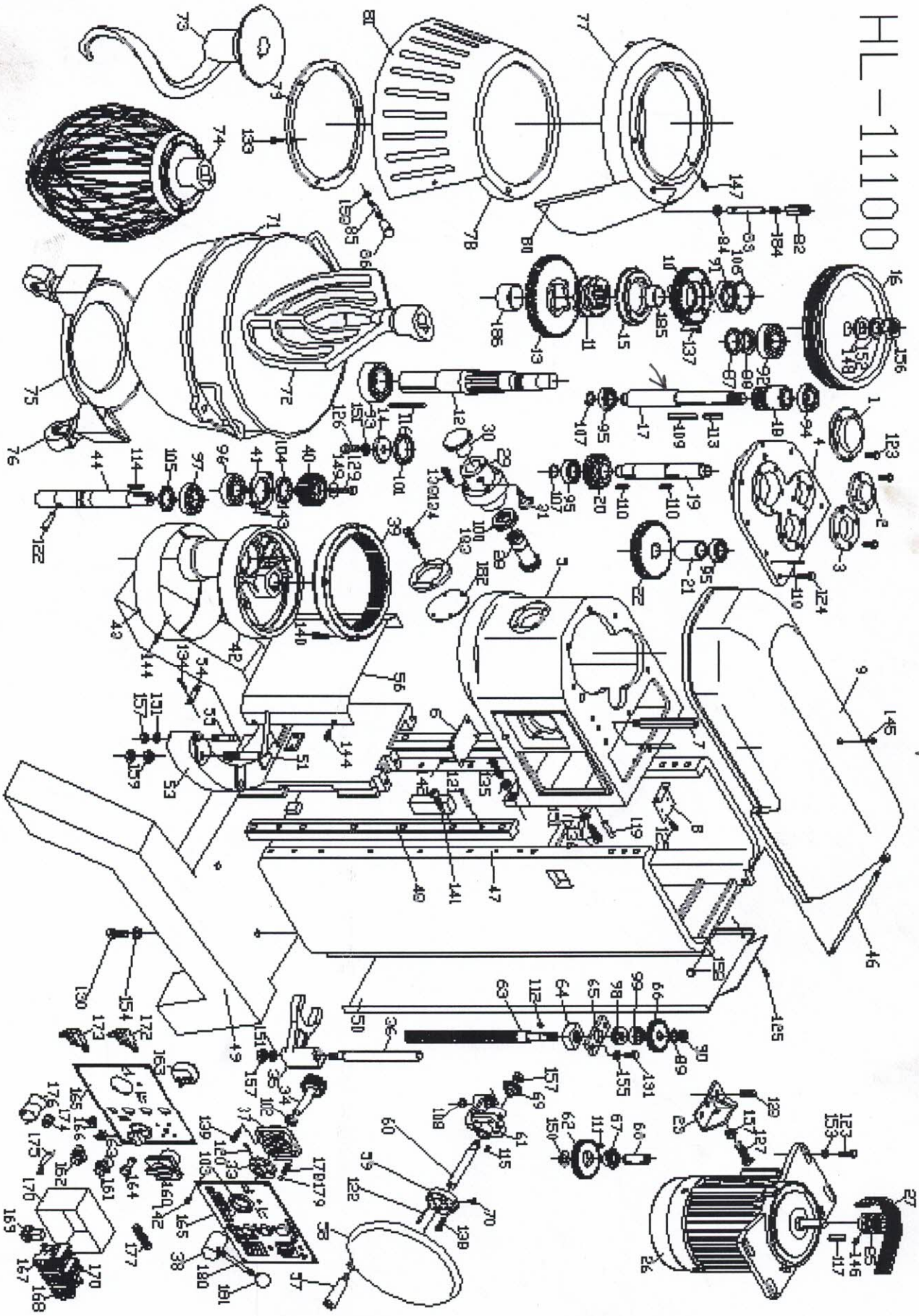

AL-MOQIAT GOQT Mixer

